

Comba

CriticalPoint™ Public Safety

V3 ANNUNCIATOR PANEL

USER MANUAL

APV3-BDA / APV3-DAS

QE: 1-0-0

Comba Telecom Limited

Table of Contents

Section		Page
0.1	INDEX TO FIGURES AND TABLES	3
0.2	REVISION HISTORY	5
0.3	ABOUT THIS MANUAL	5
0.4	DOCUMENTATION FEEDBACK	5
0.5	TECHNICAL SUPPORT	6
0.6	RETURN MATERIAL AUTHORIZATION (RMA)	6
0.7	WARRANTY	6
0.8	UNAUTHORIZED CHANGES TO EQUIPMENT	6
0.9	GLOSSARY OF TERMS	7
0.10	SAFETY NOTICES AND ADMONISHMENTS	9
0.11	AUTHORIZED EQUIPMENT OPERATORS	11
1	GENERAL PRODUCT INFORMATION	12
1.1	V3 AP SYSTEM STANDARDS COMPLIANCE	13
1.2	V3 AP MAIN FEATURES	13
1.3	V3 AP SPECIFICATIONS	14
1.4	V3 AP SYSTEM DIAGRAM – STANDARD BDA/BBU	15
1.5	V3 AP SYSTEM DIAGRAM – FIBER DAS WITH APV3-BDA	16
1.6	V3 AP SYSTEM DIAGRAM – FIBER DAS WITH APV3-DAS	17
1.7	V3 AP SYSTEM DIAGRAM – CASCADING A V1 AP TO FEED FACP	18
1.8	V3 AP SYSTEM DIAGRAM – FIBER DAS WITH V1 AP FEEDING FACP	19
1.9	V3 AP CABINET DIMENSIONS	20
1.10	V3 AP STANDARD MOUNTING BRACKET DIMENSIONS	21
1.11	V3 AP FLUSH MOUNTING BRACKET DIMENSIONS	22
1.12	V3 AP FLUSH MOUNTING FRONT PLATE DIMENSIONS	23
1.13	V3 AP INTERNAL ADDRESS DIPSWITCH LOCATION	24
1.14	V3 AP CABINET CONNECTIONS	25
2	INSTALLATION	26
2.1	WARNINGS, ALERTS AND CAUTIONS	26
2.2	SITE PLANNING CONSIDERATIONS	27
2.3	INSTALLATION CHECKLIST	28
2.4	GOODS INWARD INSPECTION	28
2.5	TOOLS	28
2.6	EQUIPMENT GROUNDING	28
2.7	V3 AP MOUNTING BRACKET PREPARATION/REMOVAL	29
2.8	V3 AP ADDRESS SETTING WHEN USING MULTIPLE AP'S	30
2.9	V3 AP MOUNTING TO GANG BOX	31
2.10	V3 AP FLUSH MOUNTING	32
2.11	V3 AP SYSTEM WIRING	41
2.12	V3 AP SYSTEM WIRING – CASCADING AP'S	43
2.13	V3 AP SYSTEM WIRING – BARE WIRE CONNECTION TO BDA/MU/RU	44
2.14	V3 BDA/MU/RU ANNUNCIATOR FRONT PLATE INSTALLATION	45
3	COMMISSIONING	48
3.1	PRE-COMMISSIONING TASKS	48
3.2	V3 BDA/MU/RU/BBU POWER ON/POWER OFF	48
3.3	WEB GUI LOGIN AND USER MANAGEMENT	48
3.4	WEB GUI INTRODUCTION	49
3.5	COMMISSIONING PROCEDURE	49
3.6	V3 AP – WEB GUI SETTINGS	50

CRITICALPOINT V3 AP USER MANUAL

4	ALARMS, TROUBLESHOOTING, AND MAINTENANCE	52
4.1	V3 AP ANNUNCIATOR LED INDICATORS, SILENCE AND LAMP TEST	52
4.2	ALARM STATUS INDICATORS IN THE WEB GUI	54
4.3	DRY-CONTACT AND AP ALARM SETTINGS	56
4.4	USER DEFINED DRY CONTACT AND LED ALARM CONFIGURATION	61
4.5	EXTERNAL ALARMS	62
4.6	V3 AP SILENCE AND LAMP TEST	63
4.7	V3 AP ALARM SIMULATIONS	64
4.8	V3 AP ALARM TROUBLESHOOTING	64
4.9	V3 AP MAINTENANCE RECOMMENDATIONS	64
5	APPENDICES	65
5.1	APPENDIX A: TOOLS	65
5.2	APPENDIX B: DECLARATION OF HARMFUL SUBSTANCES AND CONTENT	66
5.3	APPENDIX C: DEVICE PACKING LIST EXAMPLE	67

0.1 INDEX TO FIGURES AND TABLES

Figure/Table No.	Page
Figure 1: V3 Annunciator Panel for BDA	12
Figure 2: V3 Annunciator Panel for Fiber DAS	12
Figure 3: APV3-BDA - Isometric View	13
Figure 4: APV3-DAS - Isometric View	13
Figure 5: APV3-BDA - System Diagram - Standard BDA/BBU	15
Figure 6: APV3-BDA - System Diagram - Fiber DAS	16
Figure 7: APV3-DAS - System Diagram - Fiber DAS	17
Figure 8: APV3-BDA with V1 AP Cascaded for FACP Alarms	18
Figure 9: APV3-DAS with V1 AP Cascaded for FACP Alarms	19
Figure 10: APV3-BDA - Dimensions	20
Figure 11: APV3-DAS - Dimensions	20
Figure 12: APV3-BDA - Standard Mounting Bracket Dimensions	21
Figure 13: APV3-DAS - Standard Mounting Bracket Dimensions	21
Figure 14: APV3-BDA - Flush Mount Bracket Dimensions	22
Figure 15: APV3-DAS - Flush Mount Bracket Dimensions	22
Figure 16: APV3-BDA - Flush Mount Front Plate Dimensions	23
Figure 17: APV3-DAS - Flush Mount Front Plate Dimensions	23
Figure 18: V3 AP - Internal View and Addressable DIP Switch Location	24
Figure 19: APV3-BDA - Cabinet Connections	25
Figure 20: APV3-DAS - Cabinet Connections	25
Figure 21: V3 AP - Mounting Bracket Overview	29
Figure 22: V3 AP - Address Switch Setting	30
Figure 23: APV3-BDA – Mounting - Gang Box	31
Figure 24: APV3-DAS - Mounting - Gang Box	31
Figure 25: APV3-BDA - Flush Mounting to Wall	32
Figure 26: APV3-BDA - Flush Mount Kit Face Plate and Bracket Screw Removal	33
Figure 27: APV3-BDA - Mounting Standard Mounting Bracket to Flush Mount Bracket	33
Figure 28: APV3-BDA - Mounting APV3-BDA into Flush Mount Bracket	34
Figure 29: APV3-BDA - Installing Flush Mount Bracket, APV3-BDA, and Face Plate into a Wall	35
Figure 30: APV3-DAS - Flush Mounting to Wall	36
Figure 31: APV3-DAS - Flush Mount Kit Face Plate and Bracket Screw Removal	37
Figure 32: APV3-DAS - Mounting Standard Mounting Bracket to Flush Mount Bracket	37
Figure 33: APV3-DAS - Mounting APV3-DAS into Flush Mount Bracket	38
Figure 34: APV3-BDA - Installing Flush Mount Bracket, APV3-BDA, and Face Plate into a Wall	39
Figure 35: APV3-BDA and APV3-DAS Flush Mounted to Wall	40

CRITICALPOINT V3 AP USER MANUAL

Figure 36: V3 BDA/MU/RU - RJ45 Adapter for V3 APs..... 41

Figure 37: V3 BDA/MU/RU Wiring Connection to V3 AP 42

Figure 38: Cascading Multiple APV3-BDA..... 43

Figure 39: Cascading Multiple APV3-DAS..... 43

Figure 40: V3 AP - RJ45 T568B Connector Pinout for Bare Wire Connection to BDA/MU/RU 44

Figure 41: APV3-BDA - Front Alarm Plate Installation 45

Figure 42: APV3-DAS - Front Alarm Plate Installation 45

Figure 43: Commissioning Procedure..... 49

Figure 44: Commissioning V3 AP in BDA mode..... 50

Figure 45: Commissioning V3 AP in DAS Mode..... 50

Figure 46: V3 AP - Web GUI Settings..... 50

Figure 47: APV3-BDA - LED Alarm Indicators..... 52

Figure 48: APV3-DAS - LED Alarm Indicators..... 52

Figure 49: APV3-BDA - LED and Dry Contact Alarm Correlation..... 53

Figure 50: APV3-DAS - LED and Dry Contact Alarm Correlation..... 53

Figure 51: V3 BDA/MU/RU - Dry Contact and AP Alarm Setup through web GUI..... 56

Figure 52: V3 BDA/MU/RU - User Defined Dry Contact Alarm Window..... 61

Figure 53: V3 BDA/MU/RU - User Defined Dry Contact System Alarms..... 61

Figure 54: BDA/MU/RU - External Alarm Settings..... 62

Figure 55: V3 AP - Silence Button, Lamp Test Button, and Key Switch..... 63

Table 1: V3 AP - Cabinet Connections 25

Table 2: V3 AP - Address Switch Setting..... 30

Table 3: APV3-BDA - Front Alarm Plate Options..... 46

Table 4: APV3-DAS - Front Alarm Plate Options..... 47

Table 5: V3 AP - Web GUI Settings..... 51

Table 6: V3 AP - Default LED Indicators for UL2524 2018 2nd Revision 52

Table 7: V3 AP - LED Indicators – General Overview 54

Table 8: V3 BDA/MU/RU - Web GUI Alarm Status Indicators 54

Table 9: V3 BDA/MU/RU - Complete List of Device Alarms..... 55

Table 10: V3 BDA/MU/RU - Dry Contact and AP LED Alarm Presets..... 56

Table 11: NFPA 1221 2019 Alarm Preset Dry Contact and LED Operation 57

Table 12: UL2524 Oct 2018 Alarm Preset Dry Contact and LED Operation..... 58

Table 13: NFPA 1225 2022 Alarm Preset Dry Contact and LED Operation 59

Table 14: IFC 510 2021 Alarm Preset Dry Contact and LED Operation 60

0.2 REVISION HISTORY

Rev. No.	ENU	Release Date	Author	Details Of Change
1	1-0-0	9/1/2024	MD	First Release

0.3 ABOUT THIS MANUAL

This user manual describes the pre-planning, installation, commissioning, operation, and maintenance procedures for the Comba CriticalPoint™ V3 Public Safety Annunciator Panels. A complete overview of the hardware and software is provided. The hardware and software mentioned throughout this manual are under continuous development to provide improvements and/or new features. As a result, there may be minor differences between the information found in this manual and the actual design of the hardware and software received by the operator. Any specifications, weights, dimensions, or other statements mentioned in this manual are subject to change without notice.

The information contained herein is the responsibility of and is approved by the following, to whom all enquiries should be directed:

This is an unpublished work the copyright in which vests in Comba International ("Comba"). All rights reserved. The information contained herein is confidential and the property of Comba and is supplied without liability for errors or omissions. No part may be reproduced, disclosed, or used except as authorized by contract or other written permission by Comba. The copyright and the foregoing restriction on reproduction and use extend to all media in which the information may be embodied.

0.4 DOCUMENTATION FEEDBACK

Comba prides itself in providing our clients with the best customer experience possible. Your feedback can help keep our documentation current and accurate. If you have any comments or suggestions about the content found within this user manual, please feel free to contact us.

Please include the following information when submitting your comments:

- Product Model Number and Version Number
- User Manual Name and Version Number
- Topic Title or Subject
- Page Number
- Brief description of the content you believe should be improved, corrected, or is missing.
- Your recommendation for how to correct or improve the document.

Please send your email messages to the following:

techsupport@combausa.com

Please note this email is for both technical support and documentation feedback.

0.5 TECHNICAL SUPPORT

Comba provides direct access to our technical support team 12 hours a day (Mon-Fri) from 9:00am (EST) to 6:00pm (PST). Technical support is provided for free for the entire time the product is covered by the equipment warranty, on condition that the user/operator has a valid certificate of training completion issued by Comba for the product in question. Unauthorized individuals should not be servicing the equipment and will not be assisted over the phone due to liability issues.

For technical support please contact us at the telephone number or email address below or submit a ticket for support through the website.

Tel: (408) 526 0180 Ext. 3
techsupport@combausa.com
<https://combausa.com/technical-support-request-form/>

0.6 RETURN MATERIAL AUTHORIZATION (RMA)

If you need to request an RMA, please call the technical support line mentioned in section 0.5 or complete the RMA form on our website and a Comba representative will contact you shortly.

<https://combausa.com/rma-request-form/>

0.7 WARRANTY

The standard product warranty is 3 years or as otherwise agreed under a special contract with Comba. The warranty period commences upon date of shipment from Comba Telecom.

0.8 UNAUTHORIZED CHANGES TO EQUIPMENT

Any changes or modifications to the equipment not expressly approved by Comba Telecom (who are responsible for compliance) would void the user's authority to operate the equipment. Furthermore, unauthorized changes or modifications could void the device warranty. If you have any questions regarding what modifications can be made, please contact the technical support line mentioned in section 0.5.

0.9 GLOSSARY OF TERMS

Abbreviation	Definition
AGC	Automatic Gain Control
AHJ	Authority Having Jurisdiction
ALC	Automatic Level Control
AP	Annunciator Panel
ATT	Attenuator
BATT	Battery
BBU	Battery Backup Unit
BDA	Bi-Directional Amplifier
BTS	Base Transceiver Station
CH	Channel
CSA	Cross Sectional Area
dB	Decibel
dBm	Decibels relative to one milliwatt
DL	Downlink
DT	Donor Terminal (Base/Donor Port)
DPX	Duplexer
ERCES	Emergency Responder Communication Enhancement System
ERRCS	Emergency Responder Radio Communication System
FCC	Federal Communications Commission
FOU	Fiber Optic Unit
FPGA	Field-Programmable Gate Array (Digital Signal Processor)
FS	Frequency Selection
GND	Ground
GUI	Graphical User Interface
Hz	Hertz
ID	Identification
IF	Intermediate Frequency
LNA	Low Noise Amplifier
LOS	Line-of-Sight
MCU	Main Control Unit
MHz	Megahertz
MPX	Multiplexer
MT	Mobile Terminal (Service/Mobile Port)
MTBF	Mean Time Between Failures
MU	Master Unit
NF	Noise Figure
OMC	Operation & Maintenance Center
OMT	Operation & Maintenance Terminal
OP	Optical Port
PA	Power Amplifier

CRITICALPOINT V3 AP USER MANUAL

PE	Protective Earth
PLL	Phase Locked Loop
PS	Public Safety
PSU	Power Supply Unit
RF	Radio Frequency
RFU	Radio Frequency Unit
RMA	Return Material Authorization
RU	Remote Unit
RX	Receive
SMA	Sub-Miniature A Connector
TX	Transmit
UL	Uplink
VAC	Volts Alternating Current
VDC	Volts Direct Current
VSWR	Voltage Standing Wave Ratio
W	Watts

0.10 SAFETY NOTICES AND ADMONISHMENTS

This document contains safety notices in accordance with appropriate standards. In the interests of conformity with the territory standards for the country concerned, the equivalent territorial admonishments are also shown.

Installation, adjustment, maintenance, and/or repair of the equipment must only be conducted by trained/certified personnel! At all times, personnel must comply with any safety notices and instructions! Before installing, modifying, or replacing any of the equipment, the user manual should be read and understood in its entirety.

Specific hazards are indicated by symbol labels on or near the affected parts of the equipment. The labels conform to international standards, are triangular, and are colored black on a yellow background. An informative text label may accompany the symbol label.



General Warning



High Voltage



Non-ionizing Radiation Hazard



Electric Hazard



Laser Hazard

Hazard labeling is supplemented by safety notices in the applicable sections of this manual. These notices contain additional information on the nature of the hazard and may also specify precautions.

Example:



Non-ionizing Radiation Hazard

For compliance with the general population RF exposure limits, each individual antenna used for this transmitter must be installed to provide a separation distance during normal operation and must not be co-located with any other antenna for meeting RF exposure requirements.

Warning Notices:

These draw the attention of personnel to hazards that may cause death or injury to the operator or others. Examples of use are cases of high voltage, laser emission, toxic substances, point of hot temperature, etc.

Example:



Electric Hazard

WARNING. Electric Shock may occur if the signal booster is installed near water.

Alerts:

These draw the attention of personnel to hazards that may cause damage to the equipment.

Examples:



General Warning

ALERT! Disconnection of either of the RF ports (unloaded) may cause damage to the equipment when power and equipment is active.

Caution Notices:

These may also be used in the handbook to draw attention to matters that do not constitute a risk of causing damage to the equipment but where there is a possibility of seriously impairing its performance, e.g., by mishandling or gross maladjustment. Warnings and Cautions within the main text may not incorporate labels and may be in shortened form.

Example:



WARNING. This is **NOT** a **CONSUMER** device. It is designed for installation by **FCC LICENSEES** and **QUALIFIED INSTALLERS**. You **MUST** have an **FCC LICENSE** or express consent of an FCC Licensee to operate this device. The PS BDA can be configured as Class A or Class B Signal Booster. You **MUST** register Class B signal boosters (as defined in 47 CFR 90.219) online at www.fcc.gov/signal-boosters/registration. Unauthorized use may result in significant forfeiture penalties, including penalties of more than \$100,000 for each continuing violation.

Note: The grantee is not responsible for any changes or modifications not expressly approved by the party responsible for compliance. Such modifications could revoke the user's authority to operate the equipment.



CAUTION! Use only authorized and approved antennas, cables and/or coupling devices! The use of unapproved antennas, cables or coupling devices could cause damage and may be a violation of FCC regulations. The use of unapproved antennas, cables and/or coupling devices is illegal under FCC regulations and may subject the user to a fine.



CAUTION! Ambient temperature range for equipment use: -33 to 55 degrees Celsius.



CAUTION! This equipment is not suitable for use in locations where children are likely to be present.



CAUTION! The product shall have a connection of the equipment protective earthing conductor to the installation protective earthing conductor (for example, by means of a power cord connected to a socket-outlet with earthing connection).



CAUTION! When the plug on the power supply cord is used as the disconnect device, the socket-outlet shall be easily accessible.

0.11 AUTHORIZED EQUIPMENT OPERATORS

Signal Boosters (Also referred to BDAs or Fiber Fed BDAs) and their sub-components are not consumer devices. They are industrial devices which may only be operated and maintained by authorized individuals and qualified installers.

- Operators/Installers of the equipment **MUST** have taken and passed Comba Telecom's certification training program for the V3 BDA/DAS/BBU.
- Operators of the equipment **MUST** have a valid FCC General Radio Operator License (GROL).
- It is recommended for operators and installers to have completed NICET Levels 1 and 2 for ERCES.
- Non-Licensee Operators **MUST** receive express written consent to operate the Signal Booster from the FCC License Holder **BEFORE** installing and operating the device.

The equipment must be installed and operated in accordance with any license required from the radio authorities in the country of concern. In most cases, it is a criminal offense if one fails to obtain a license to install and operate the equipment. It is the operator's responsibility to ensure any required licenses are obtained, that systems are installed and commissioned in accordance with their terms, and that no changes can be made later that would disobey them.

Comba reserves the right to seize sales to a client and/or report the violation to the proper authorities should we determine a client is allowing unauthorized individuals to operate the equipment. Comba will not be held responsible for unauthorized use of our devices.

End of Section

1 GENERAL PRODUCT INFORMATION

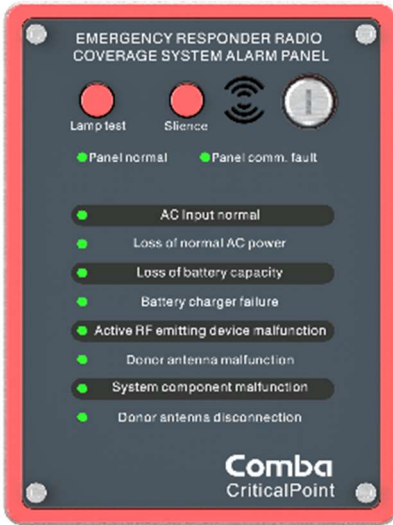

Figure 1: V3 Annunciator Panel for BDA

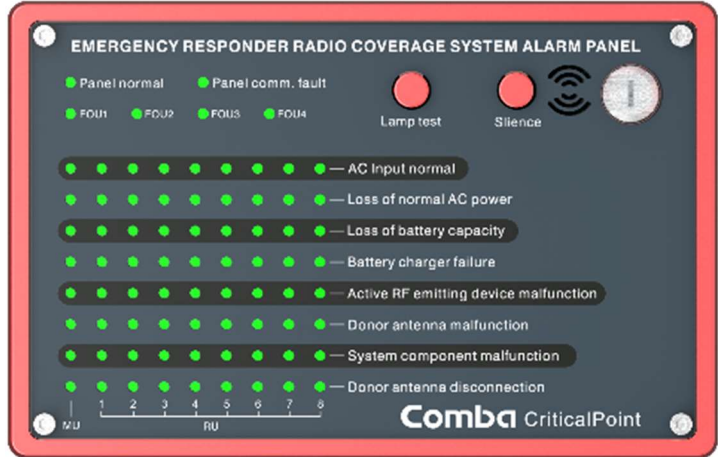

Figure 2: V3 Annunciator Panel for Fiber DAS

The CriticalPoint™ V3 Annunciator Panel (AP) is a system designed to provide audible and visual annunciation of ERRCS/ERCES alarms per the latest IFC, NFPA, and UL codes and standards. The devices are specifically designed to provide status indication for all Comba V3 BDA, BBU and Fiber DAS products. Furthermore, the annunciator panels can only be used together and managed by Comba V3 BDA, BBU and Fiber DAS products. The annunciator panel will display the status of the whole system it is connected to, including system Amplifiers (BDA, Master Unit, or Remote Unit), Fiber Optic Expansion Units (FOUs) and Battery Backup Units (BBUs).

The V3 AP is available in two different models. The model **APV3-BDA** is designed to be used with a stand-alone V3 BDA/BBU system or where a summarization of Fiber DAS Remote BDA/BBU alarms is permitted. Each APV3-BDA can handle system alarms for (1) BDA, (1) MU, or (1) RU and its associated BBU. Up to (4) APV3-BDA can be connected in cascade from each BDA, MU, or RU if multiple annunciators are required to be located throughout the building.

The model **APV3-DAS** is designed to be used with the V3 Fiber DAS configuration when individual annunciation of device alarms is required (Individual alarm LEDs for each Master Unit, Fiber Optic Unit, Remote Units, and BBUs). Each APV3-DAS can handle independent system alarms for (1) MU+BBU, (1) FOU, and (8) RU+BBU. Up to (4) APV3-DAS can be connected in cascade from a BDA/MU to support a system consisting of (1) MU, (4) FOUs, (32) RUs, and (33) BBUs.

Each AP model is provided with multiple front alarm plate options for the user to choose from to meet their local alarm requirements. The alarm plate options provided with the annunciators have a similar layout to those provided with the V3 BDA/MU and RU devices and mirror the same alarm configuration. The V3 annunciator models are used for audible and visual annunciation of alarms only. They DO NOT provide any Dry-Contact Alarm Outputs to feed a fire alarm system. The V3 annunciators allow for flush mounting to a wall, or mounting to a Gang box, which is further explained in the following sections of this manual. A “Silence” and a “Lamp Test” button are included on the exterior of the device. The provided key must be used to silence alarms or test the lamps/LEDs. The device uses RJ45 connectors for ease of installation using cat 5/6 cable. The BDA/MU/RU devices are now provided with an RJ45 adapter cable to be used to connect between the BDA/MU/RU AP power and communication terminals and a standard RJ45 ethernet cable.

1.1 V3 AP SYSTEM STANDARDS COMPLIANCE

- Complies with IFC / NFPA / UL2524
- UL 2524 Standard 2nd Edition Certified – SGS Certificate:
 - APV3-BDA: **SGSNA/24/GZ/00199**
 - APV3-DAS: **SGSNA/24/GZ/00200**
- IP30 enclosure

1.2 V3 AP MAIN FEATURES



Figure 3: APV3-BDA - Isometric View



Figure 4: APV3-DAS - Isometric View

- Dedicated External Annunciator Panel for Comba Public Safety V3 BDA.
- Dedicated External Annunciator Panel for Comba Public Safety V3 Fiber DAS displaying individual alarms from each MU, FOU, and RU.
- Swappable front alarm plates to meet various alarm standards (matches plates on V3 BDA/MU/RU)
- Supports visual and audible alarm annunciation only.
- Supports Lamp Testing and Alarm Muting via external key-switch and buttons.
- Operates on +12~+42.4VDC; powered from Comba V3 BDA/MU/RU or by a local AC/DC adaptor.
- Supports long distances (up to 2000ft using 24AWG cable)
- Lightweight and small footprint. Easy to install and commission.
- UL2524 2nd Edition Listing with SGS. SGS is a Nationally Recognized Testing Laboratory (NRTL) approved by OSHA for the UL2524 Standard.

1.3 V3 AP SPECIFICATIONS

Specifications

Annunciator Panel BDA Version		
NFPA/IFC/UL2524 Alarm Indicators		8 Alarms, synchronized with BDA V3/DAS V3
Other Alarm Indicators		Panel Normal / Comm Alarm
Max. Number of AP supported by V3 platform		4
DAS Support (For individual alarms from RUs)		N/A
Dimensions, H x W x D	In(mm)	5.75 x 4.33 x 1.81 (146 x 110 x 46)
Weight BDA	lb(kg)	0.9 (0.41)
Power Consumption	W	0.6
Annunciator Panel DAS Version		
NFPA/IFC/UL2524 Alarm Indicators		8 Alarms, synchronized with BDA/DAS, 1 MU and 8 RU supported per panel
Other Alarm Indicators		Panel Normal / Comm Alarm / FOU 1 ~ 4 Alarm
Max. Number of AP supported by V3 platform		4
DAS Support (For individual alarms from RUs)		Up to Master Unit and 32 Remote Units alarm annunciation from 4 cascaded APs
Dimensions, H x W x D	In(mm)	7.20 x 4.65 x 1.42 (183 x 118 x 36)
Weight DAS	lb(kg)	1.2 (0.54)
Power Consumption	W	2
Common Specifications		
Audio Annunciation / Buzzer Muting		Available
Lamp Test		Available
Limited Access for Operation (Alarm Muting)		Key Operated
Dry Contact Input		N/A
Dry Contact Output		N/A
Common Mechanical and Electrical Specifications		
DC Input	VDC	+12 ~ +42.4
Mounting		4" x 4" Junction Box / Wall
Max Cable Distance	Feet	2000 (24ga wire)
Connection with BDA/DAS		DC + RS485 (1x Cat. 5 Cable provided for quick connection)
IP / NEMA / Environment Class		IP30
Operating Temperature and Humidity	°F/°C	-27.4 ~ +131 (-33 ~ +55)

Part Numbers

Part Number	Description
APV3-BDA	Annunciator Panel V3 for BDA V3 or individual DAS Remote Units V3, UL 2524 Standard Certified
APV3-DAS	Annunciator Panel V3 for DAS V3, Individual Alarm Annunciation for entire system, UL 2524 Standard Certified
APV3-BDA-3804MX	Flushing Mounting Kit for APV3-BDA
APV3-DAS-3804MX	Flushing Mounting Kit for APV3-DAS

1.4 V3 AP SYSTEM DIAGRAM – STANDARD BDA/BBU

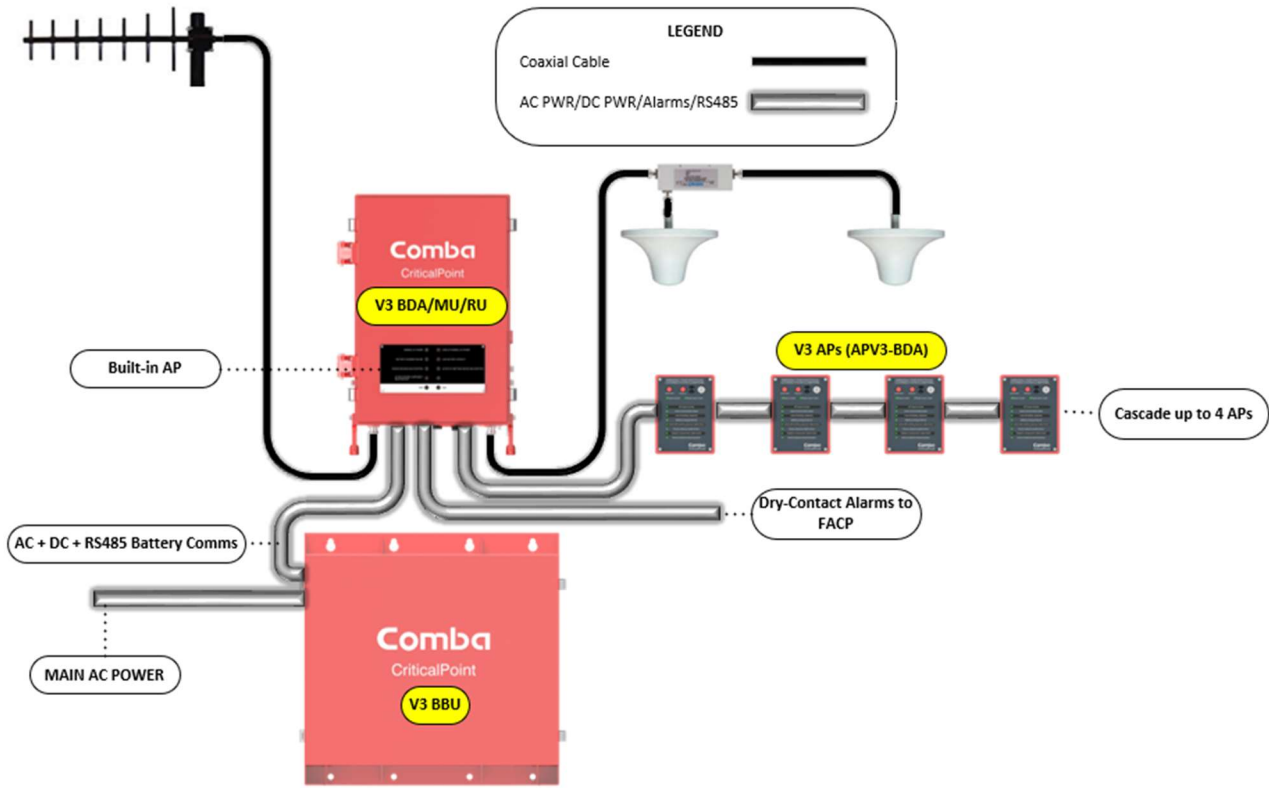

Figure 5: APV3-BDA - System Diagram - Standard BDA/BBU

The APV3-BDA Annunciator Panels receive DC Power and RS485 Alarms Communications from the V3 BDA/MU/RU device. System status and alarms that are configured in the BDA/BBU are displayed on the AP and a buzzer is sounded when an alarm becomes active. Up to (4) APs can be cascaded from the BDA up to a total distance of 2000ft to the furthest AP using a 24AWG cable. The recommended cable to use between the BDA and AP devices is a category 5 or 6 ethernet cable terminated with RJ45 connectors. The BDA devices are provided with an adapter cable which can be used to combine the BDA Annunciator Panel Terminal Outputs into an RJ45 connector. The APV3-BDA AP itself has an RJ45 connector already installed so there is no need for an adapter on that end. Alarms can be muted by using the Key Switch and pushing the “Silence” button. A Lamp Test can be performed by using the Key Switch and pushing the “Lamp Test” button.

1.7 V3 AP SYSTEM DIAGRAM – CASCADING A V1 AP TO FEED FACP

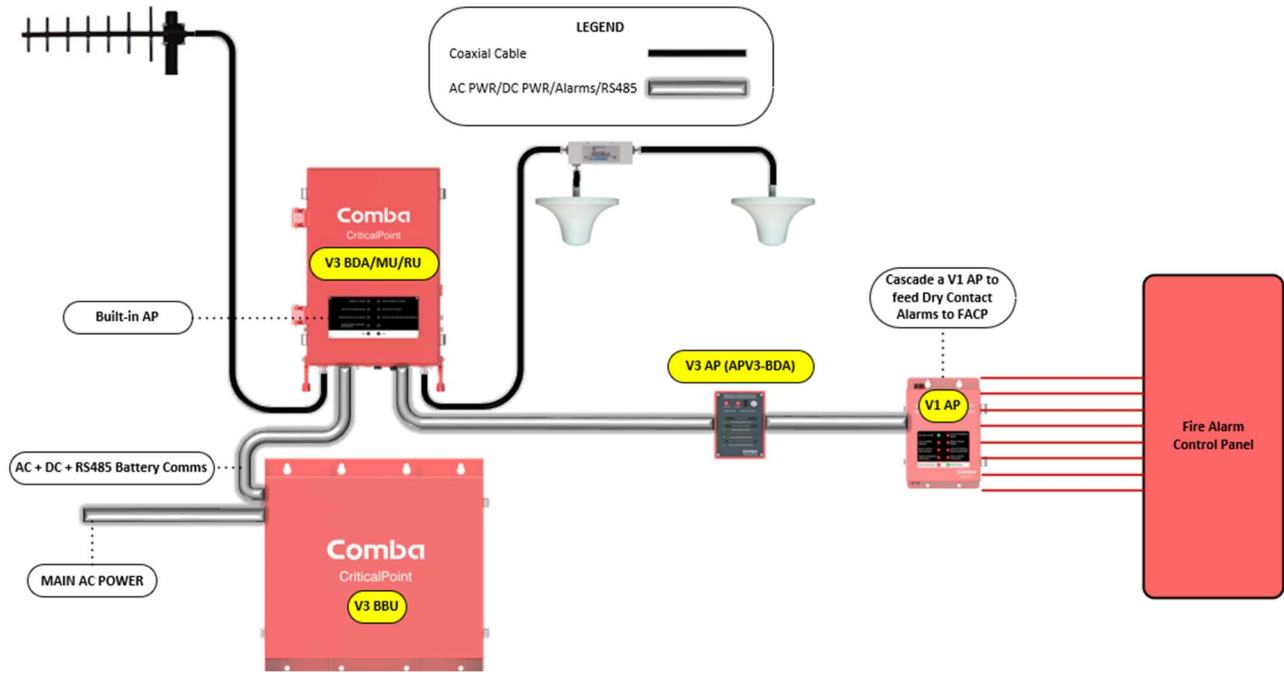

Figure 8: APV3-BDA with V1 AP Cascaded for FACP Alarms

A V1 AP can be connected in cascade from or in parallel to an APV3-BDA to provide up to (8) Dry-Contact alarm outputs to feed a Fire Alarm Control Panel.

1.8 V3 AP SYSTEM DIAGRAM – FIBER DAS WITH V1 AP FEEDING FACP

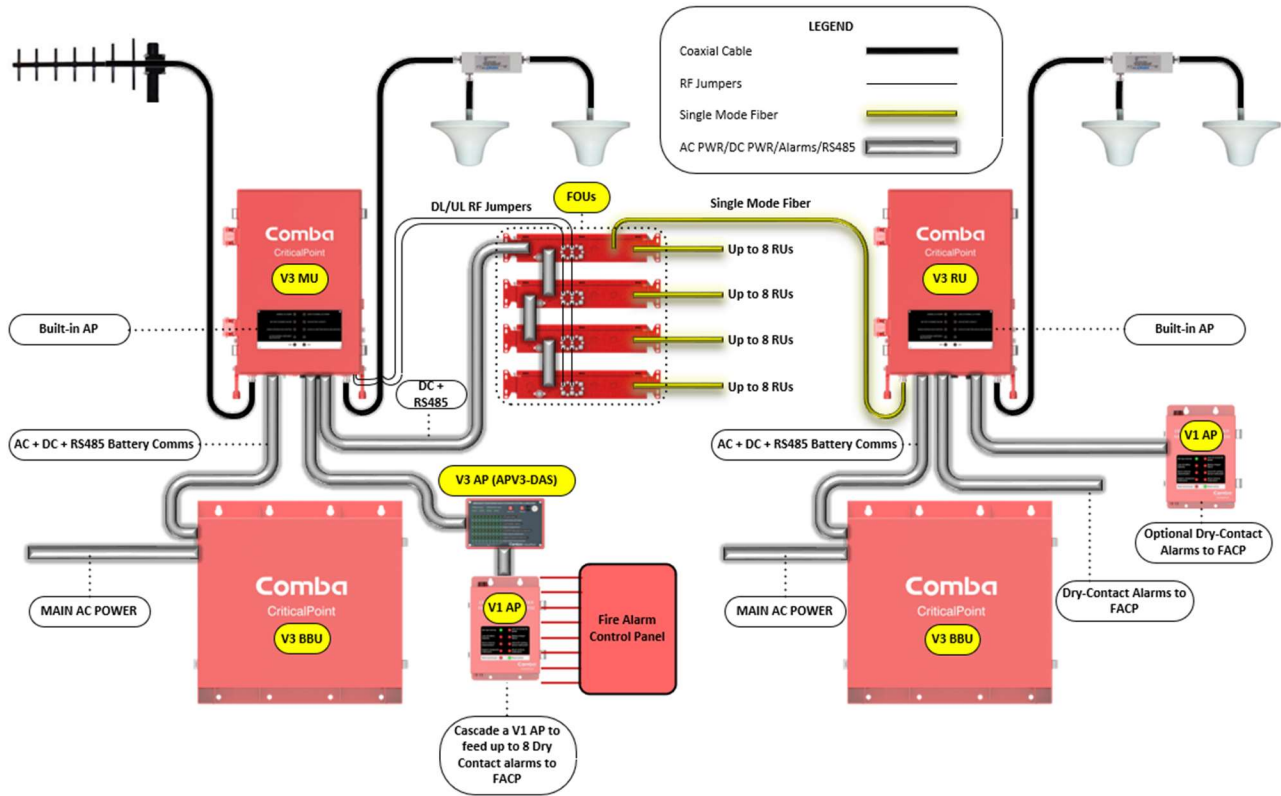

Figure 9: APV3-DAS with V1 AP Cascaded for FACP Alarms

A V1 AP can be connected in cascade from or in parallel to an APV3-DAS to provide up to (8) Dry-Contact alarm outputs to feed a Fire Alarm Control Panel. If a V1 AP is used for this purpose, only (1) APV3-DAS can be installed before the V1 AP, limiting the number of status and alarm indications for up to 8 Remotes. Furthermore, a V1 AP can be installed on a Remote Unit to feed Dry-Contact alarms to a local FACP for the specific RU.

1.9 V3 AP CABINET DIMENSIONS

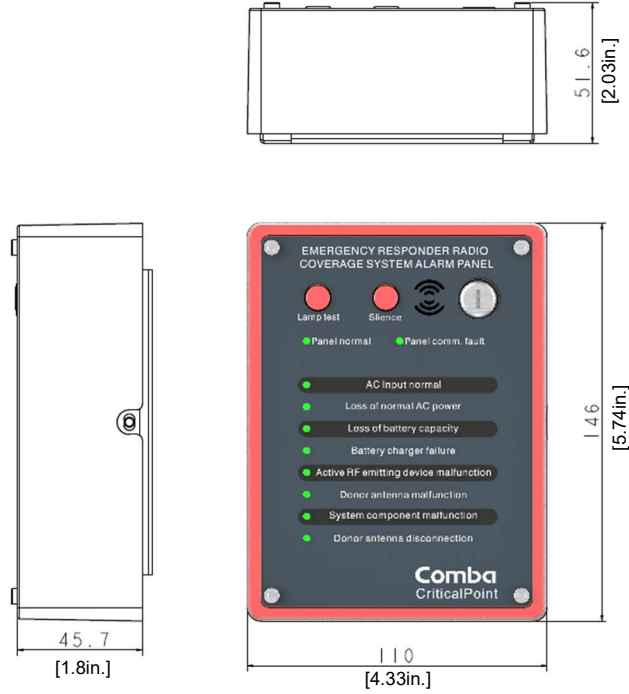

Figure 10: APV3-BDA - Dimensions

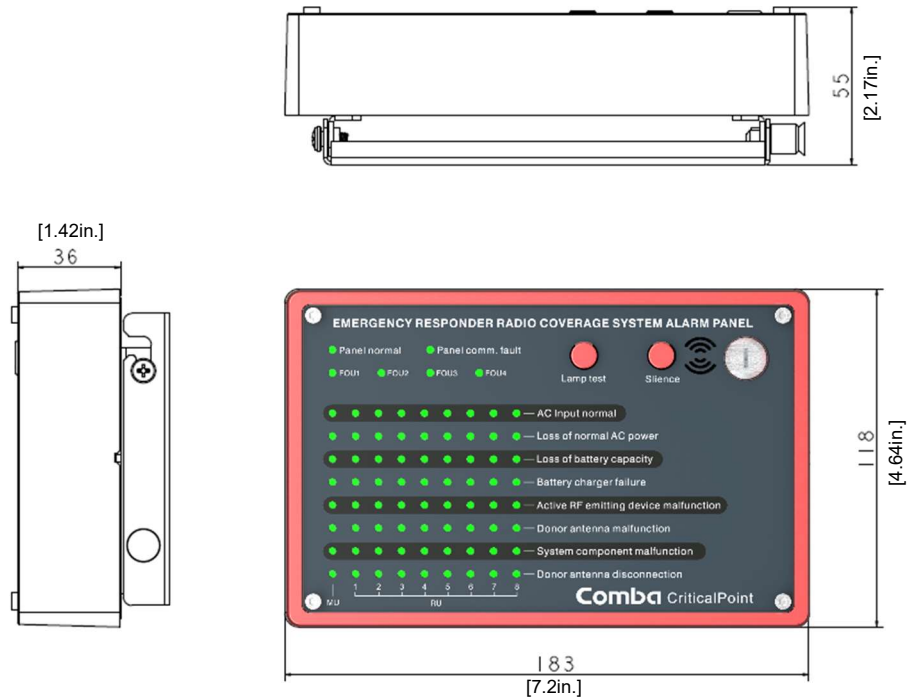

Figure 11: APV3-DAS - Dimensions

1.10 V3 AP STANDARD MOUNTING BRACKET DIMENSIONS

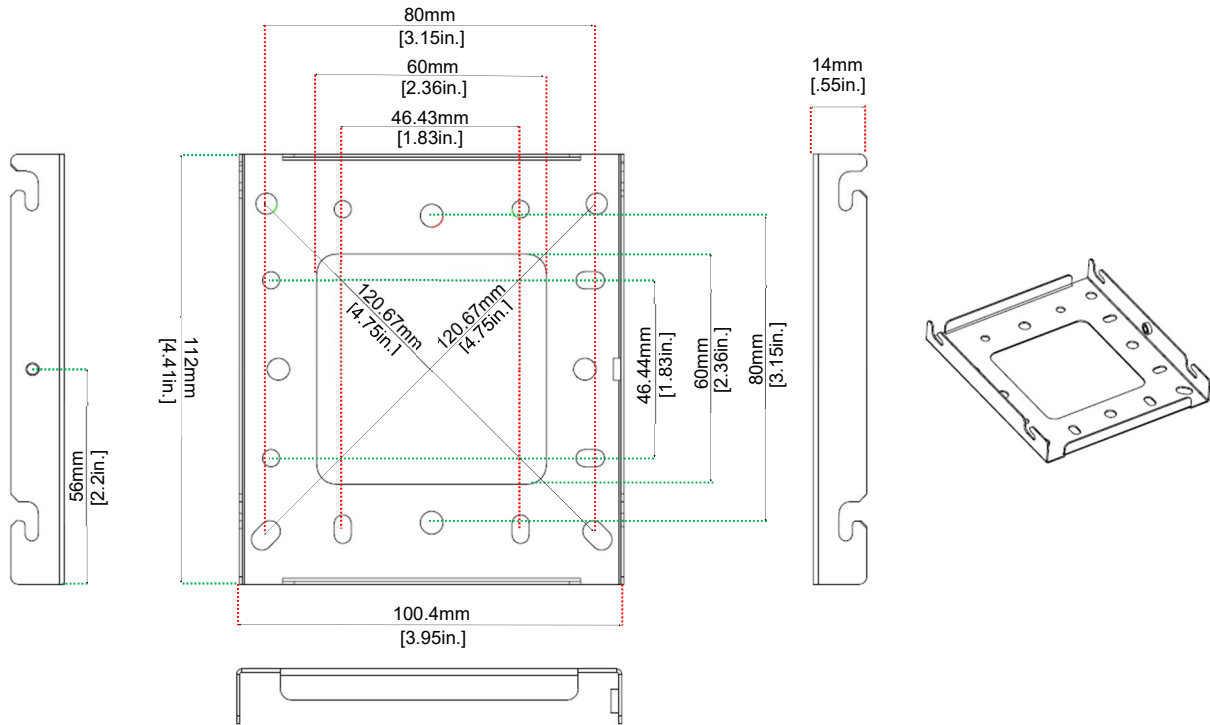

Figure 12: APV3-BDA - Standard Mounting Bracket Dimensions

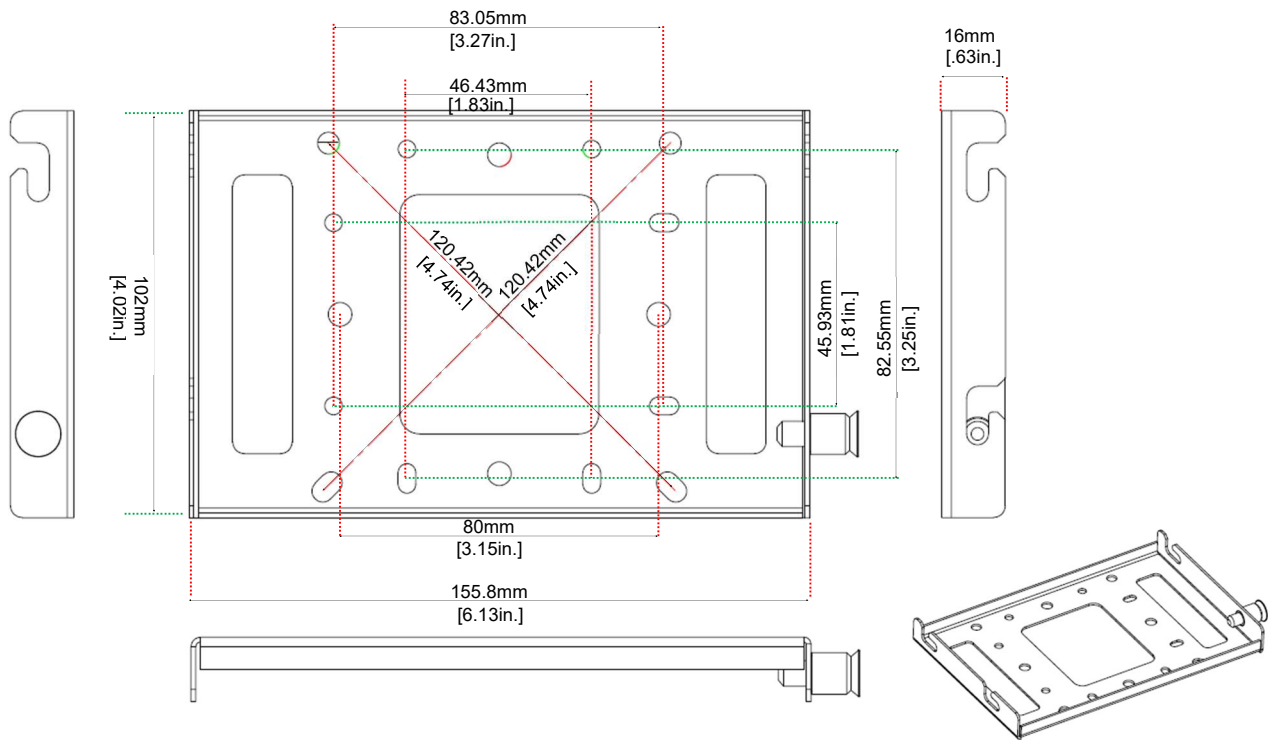

Figure 13: APV3-DAS - Standard Mounting Bracket Dimensions

1.11 V3 AP FLUSH MOUNTING BRACKET DIMENSIONS

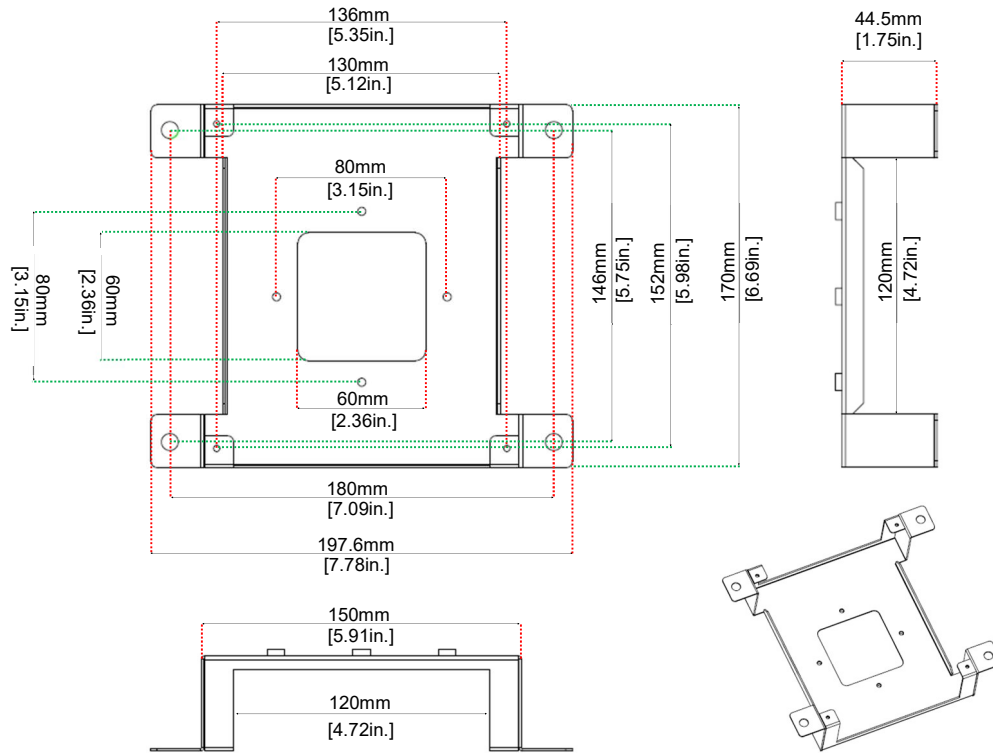

Figure 14: APV3-BDA - Flush Mount Bracket Dimensions

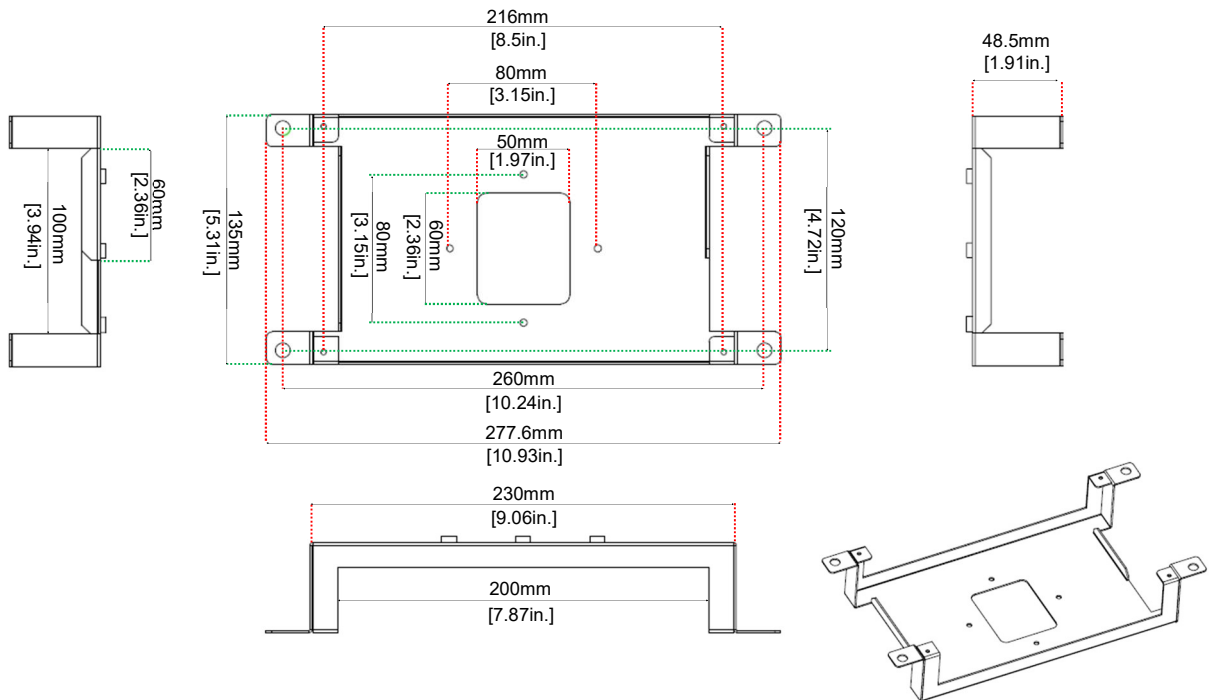

Figure 15: APV3-DAS - Flush Mount Bracket Dimensions

1.12 V3 AP FLUSH MOUNTING FRONT PLATE DIMENSIONS

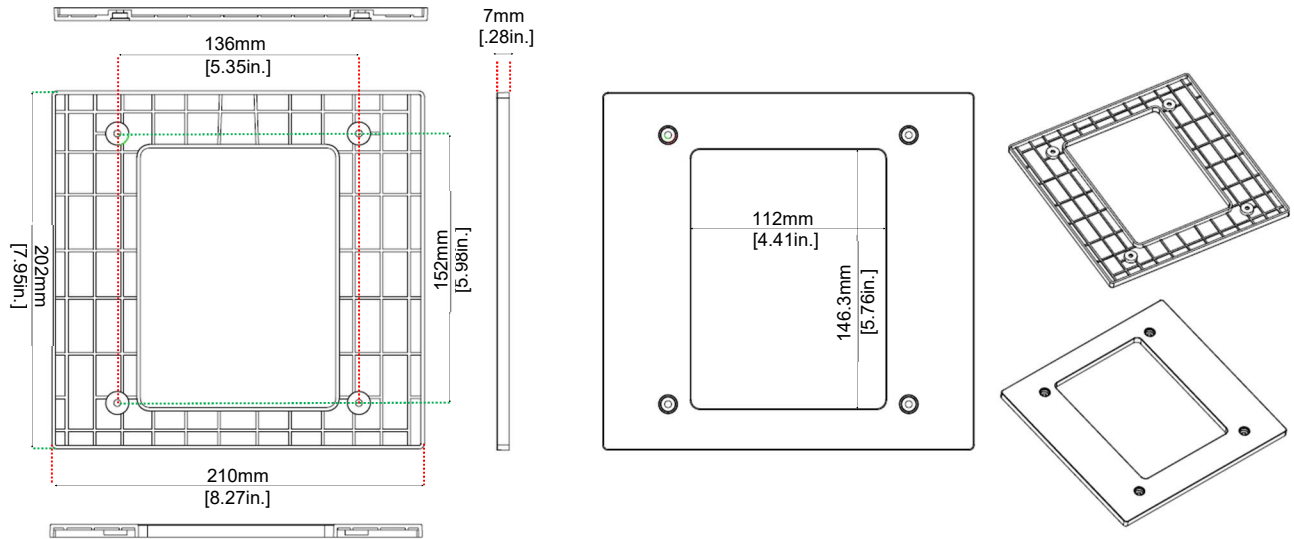

Figure 16: APV3-BDA - Flush Mount Front Plate Dimensions

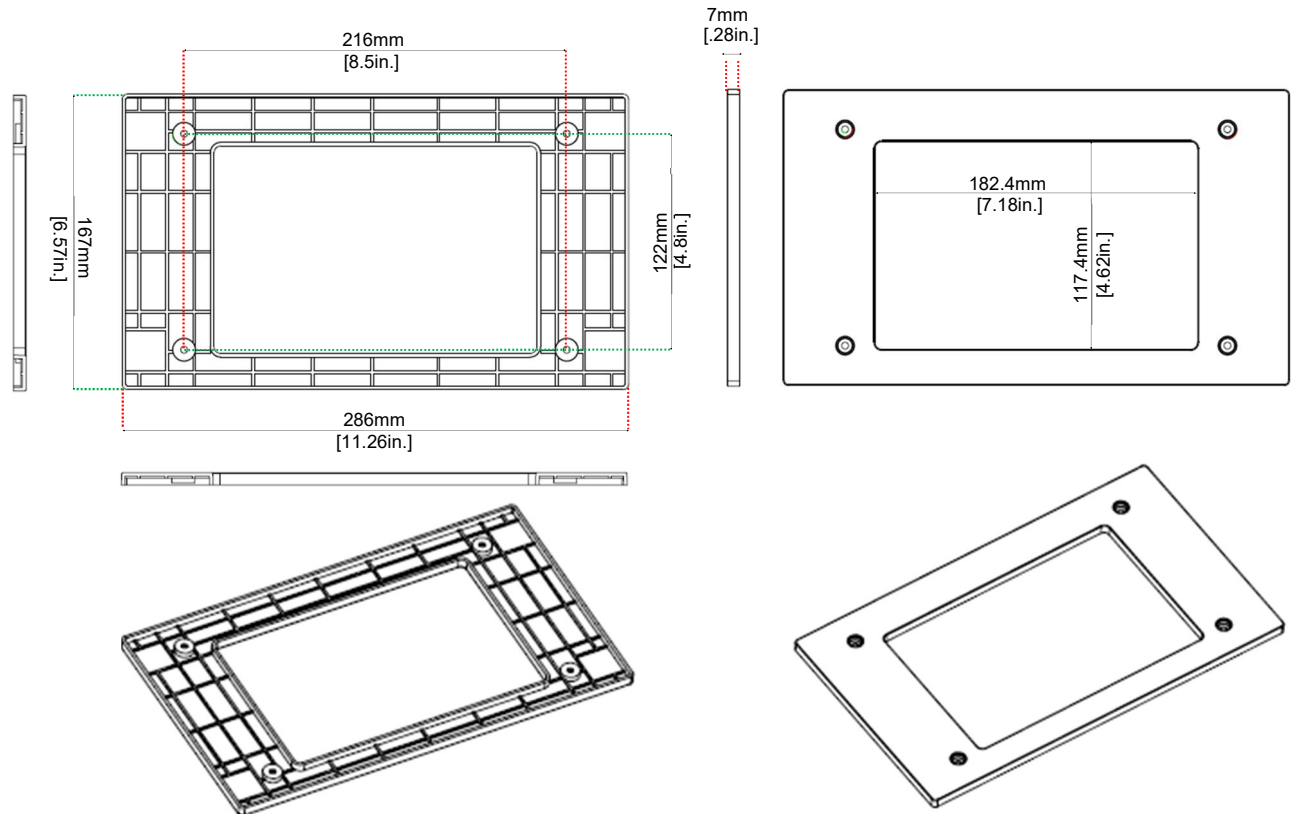

Figure 17: APV3-DAS - Flush Mount Front Plate Dimensions

1.13 V3 AP INTERNAL ADDRESS DIPSWITCH LOCATION

Each V3 AP is addressable and contains a 4-position DIP Switch for the purpose of cascading or paralleling multiple annunciators from a single BDA/MU/RU device. Each V3 AP has a default address of “1” set from the factory. If only using one AP, the address can be left to the default address of “1”. If cascading or paralleling multiple APs, each AP must have a different address to allow for proper RS485 alarm communication between all the devices. For those cases, you must remove the back cover from the annunciator panel to access the DIP Switch, then set the address accordingly, see Figure 18 below. Further details are provided in the installation section of this manual.

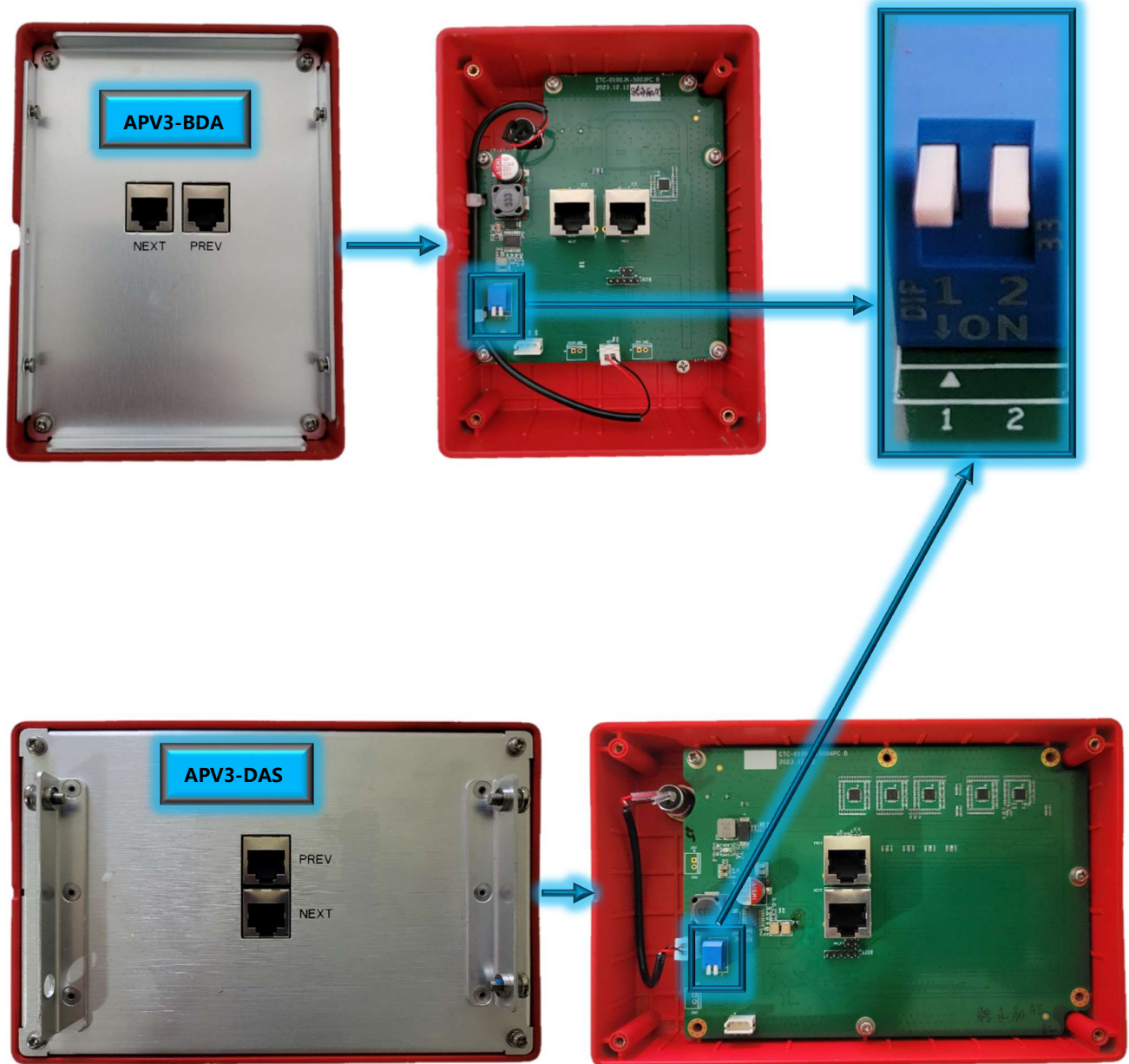

Figure 18: V3 AP - Internal View and Addressable DIP Switch Location

1.14 V3 AP CABINET CONNECTIONS

Refer to Figures 19 and 20, and Table 1 below.

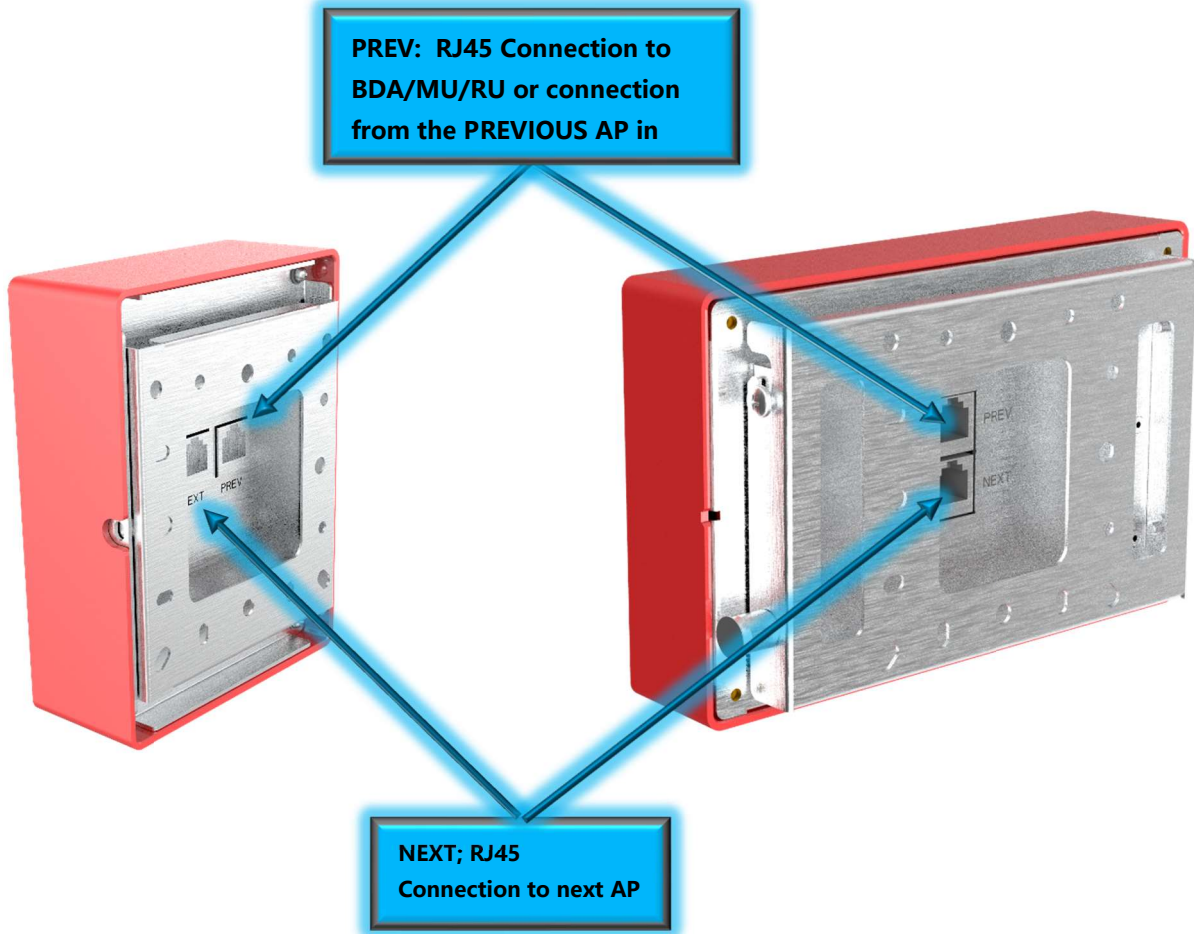

Figure 19: APV3-BDA - Cabinet Connections

Figure 20: APV3-DAS - Cabinet Connections

Table 1: V3 AP - Cabinet Connections

Identifier	Descriptions
PREV	RJ45 Connector; Connection for BDA/MU/RU when the AP is standalone or 1 st in cascade. Connection to previous AP if the AP is cascaded from another AP.
NEXT	RJ45 Connector; Connection to next AP in cascade PREV port. If not cascading APs, this port is unused.

End of Section

2 INSTALLATION

2.1 WARNINGS, ALERTS AND CAUTIONS



Safety to personnel

Before installing, modifying, or replacing any of the equipment, the user manual should be read and understood in its entirety. The user needs to supply the appropriate AC or DC power to the equipment. Incorrect power connections can damage the equipment and may cause injury to the user.



HOT SURFACE

Be aware that in certain conditions the devices can become very warm and can cause minor injuries if handled without the appropriate Personal Protective Equipment (PPE) such as gloves.



Non-ionizing Radiation Hazard

Radio Frequency Energies

There may be situations, particularly for workplace environments near high-powered RF sources, where recommended limits for safe exposure of human beings to RF energy could be exceeded. In such cases, restrictive measures or actions may be necessary to ensure the safe use of RF energy.



High Voltage

High Voltage

The equipment has been designed and constructed to prevent, as far as reasonably practicable danger. Any work activity on or near equipment involving installation, operation or maintenance must be, as far as reasonable, free from danger. Where there is a risk of damage to electrical systems involving adverse weather, extreme temperatures, wet, corrosive, or dirty conditions, flammable or explosive atmospheres, the system must be suitably installed to prevent danger.



Electric Hazard

Protective Earthing

Equipment provided for the purpose of protecting individuals from electrical risk must be suitable for the purpose and properly maintained and used.



General Warning

Handling Precautions

This covers a range of activities including lifting, lowering, pushing, pulling, carrying, moving, holding, or restraining an object, animal, or person from the equipment. It also covers activities that require the use of force or effort, such as pulling a lever, or operating power tools. Where some of the above-mentioned activities are required, the equipment must be handled with care to avoid being damaged.



General Warning

Electrostatic Discharge (ESD)

Observe standard precautions for handling ESD-sensitive devices. Assume that all solid-state electronic devices are ESD-sensitive. Ensure the use of a grounded wrist strap or equivalent while working with ESD-sensitive devices. Transport, store, and handle ESD-sensitive devices in static-safe environments.

2.2 SITE PLANNING CONSIDERATIONS



Site Considerations

This device is not designed for outdoor use. Temporary protection should be taken when the equipment enclosure is opened for installation or maintenance in any harsh environment. The equipment must not be opened for installation or maintenance outdoors in harsh weather (e.g. gale, storm rainfall, extreme temperatures, and high humidity).



Installation Location

The mounting surface shall be capable of supporting the weight of the equipment. To avoid electromagnetic interference, a proper mounting location must be selected to minimize interference from electromagnetic sources such as large electrical equipment.



Environmental

Humidity has an adverse effect on the reliability of the equipment. It is recommended to install the equipment in locations having stable temperatures and unrestricted airflow. The installation location for the product should be well ventilated. The equipment has been designed to operate at the temperature range and humidity level as stated in the product specifications in the datasheet. Direct sunlight exposure to the equipment should be avoided. Provide additional shelter if necessary.



Power Supply

The power supply unit (PSU) provides power to all modules within the equipment. It is recommended that the PSU be operated on a dedicated circuit breaker or fused circuit.



Grounding Requirement

Verify that the equipment has been well grounded. This includes antennas and all cables connected to the system. Ensure lightning protection for the antennas is properly grounded.



Cable Routing

Depending on equipment configuration, a variety of types of cables may be required. Where applicable, ensure cables are properly routed and secured so that they are not damaged.



Manual Handling

During transportation and installation, take necessary handling precautions to avoid potential physical injury to the installation personnel and the equipment.

2.3 INSTALLATION CHECKLIST

- Working space available for installation and maintenance for each mounting arrangement. Ensure unrestricted airflow.
- Ensure earth ground point is within reach of the ground wire.
- Ensure a power source is within reach of the device and the power source has sufficient capacity.
- Do not locate the equipment near large transformers or motors that may cause electromagnetic interference.
- Ensure equipment will be operated within the stated environment (see datasheet)
- Observe handling of all cables to prevent damage.
- Ensure the required tools are on hand to perform the installation work.

2.4 GOODS INWARD INSPECTION

- Verify the number of packages received against the packing list.
- Check all packages for external damage; report any external damage to the shipping courier. If there is damage, a shipping agent should be present before unpacking and inspecting the contents because damage during transit is the responsibility of the agent.
- Open and check each package against the device packing list. If any items are missing, contact Comba technical support.
- Do not remove items from anti-static packing until it is ready for installation. If damage is discovered at the time of installation, contact the shipping agent.

See Appendix C for an example device packing list.

2.5 TOOLS

See Appendix A for a full list of the recommended tools required for installation and routine maintenance.

2.6 EQUIPMENT GROUNDING

The Ground Connection should be the first wire connection made to any device after it has been successfully mounted and secured. Please ensure all equipment has been properly grounded before making wire connections to the annunciator panels. The V3 AP itself does not require a ground.

The BDA/MU/FOU/RU cabinets must be grounded securely by connecting a copper wire (CSA 16mm²) to the grounding terminal connection of the equipment, and the other end to a protective ground (i.e., building earth point). An internationally acceptable color code of the ground connection wire is green/yellow.

Such a ground connection implements the “Protective Ground Connection” and must be connected to the equipment at the designated ground point. In general, do not connect the main power supply before establishing an adequate ground (earth) connection.

Construct the ground wire and use appropriate crimp connectors where necessary. Locate and connect the equipment grounding terminal to a protective ground (i.e., building earth point).

Note: Follow local jurisdiction codes.

2.7 V3 AP MOUNTING BRACKET PREPARATION/REMOVAL

The BDA/MU and RU devices come from the factory with the mounting bracket attached to the panel enclosure. Prior to installation, you may have to remove the mounting bracket from the panel enclosure. For APV3-BDA, remove the Hex screw on the right side of the device using the provided hex tool and push down on the bracket for it to detach. Retain the Hex screw to be used for final installation. For APV3-DAS, pull on the spring-loaded pin lock and pull down on the bracket for it to detach. Refer to Figure 21 below.

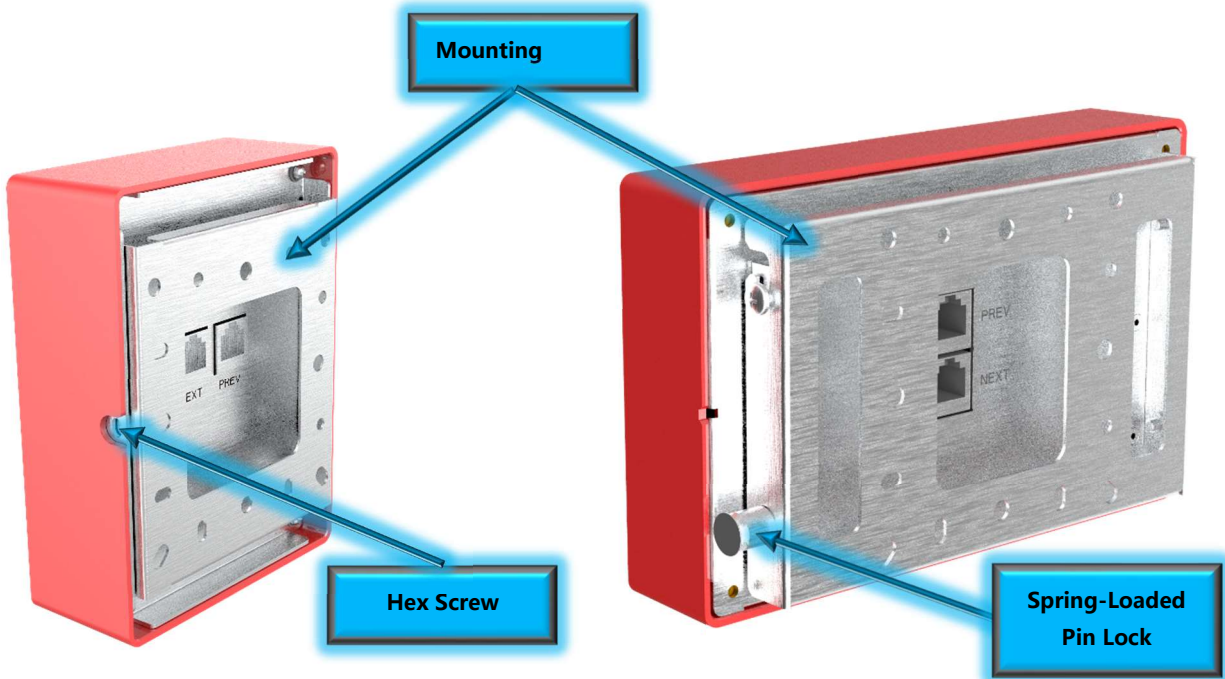

Figure 21: V3 AP - Mounting Bracket Overview

2.8 V3 AP ADDRESS SETTING WHEN USING MULTIPLE AP'S

When using multiple APs in cascade or parallel from a BDA/MU/RU device, each AP must be addressed so they can communicate properly with the BDA/MU/RU over RS485 protocol. A 4-position DIP Switch is located on the internal PCB board and is used to set the address. When BDA/MU/RU is connected to one AP, the address of the AP is set to 1. This is also the default address set from the factory. When two APs are connected, the addresses are set to 1 and 2. A maximum of two APs can be connected in parallel. When APs are being connected in cascade/series, each AP must be addressed according to its position in the chain, with the 1st AP addressed as 1, and the 4th AP addressed as 4 (MAX of 4 in cascade). The display of FOU1~FOU4 in APV3-DAS is associated with the address of the alarm panel. For example, when both DIP Switches are in the ON position, the address of the alarm panel is 4, and the FOU4 light for that APV3-DAS will illuminate, indicating that the panel displays an alarm for RUs connected to FOU4. Refer to Figure 22 and Table 2 below.

Use the below instructions to change the address of a V3 AP **BEFORE** installing:

- Lay the V3 AP down on its face. Remove the mounting bracket if it is attached.
- Remove the (4) Philips head screws holding the backplate in place. Remove the backplate.
- Change the address on the DIP switch accordingly. Refer to following table for guidance.
- Reinstall the backplate.

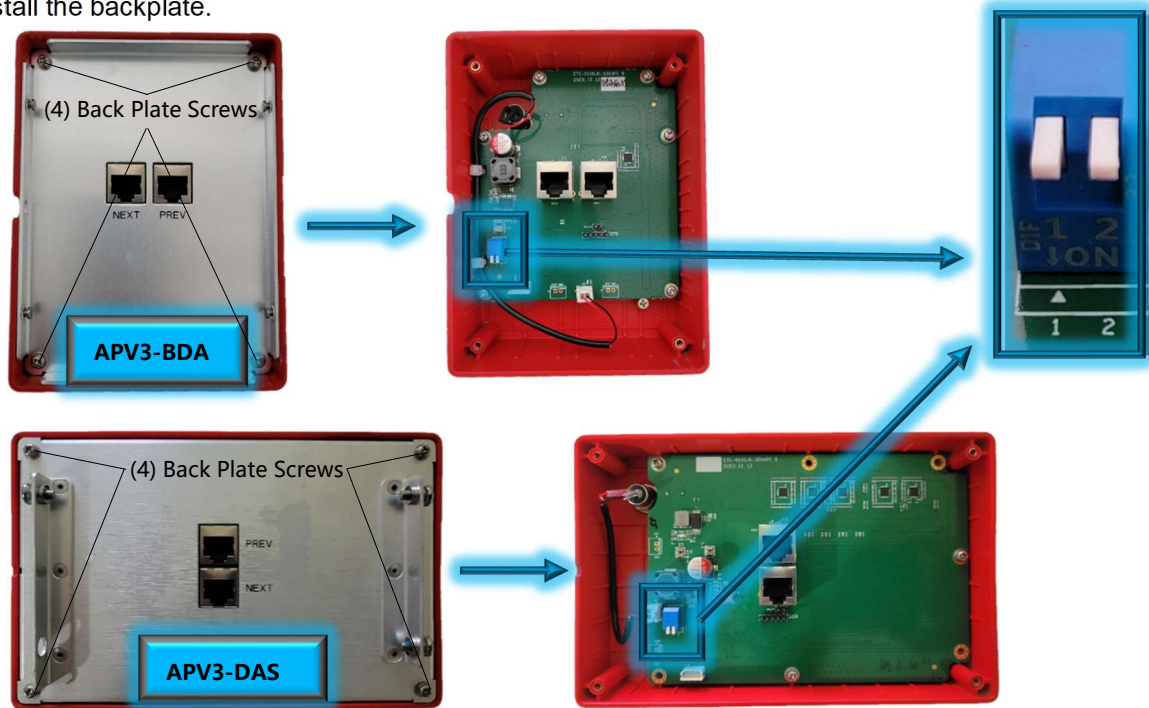

Figure 22: V3 AP - Address Switch Setting

Table 2: V3 AP - Address Switch Setting

Switch Pin 1	Switch Pin 2	Address of Alarm panel
OFF	OFF	1 (Default)
ON	OFF	2
OFF	ON	3
ON	ON	4

2.9 V3 AP MOUNTING TO GANG BOX

Follow the below instructions to mount the V3 AP to a 2-gang junction box. Reference Figures 23 and/or 24.

- Install the AP mounting bracket on the 2-gang junction box using the installation holes and corresponding (4) screws according to the specific junction box. Screws are not included.
- Run the ethernet RJ45 cable through the center of the mounting bracket and connect to the AP device.
- Align and hang the AP on the mounting bracket. For APV3-BDA, secure the AP to the bracket using the provided Hex screw. For APV3-DAS, secure the AP to the bracket using the provided spring pin lock.

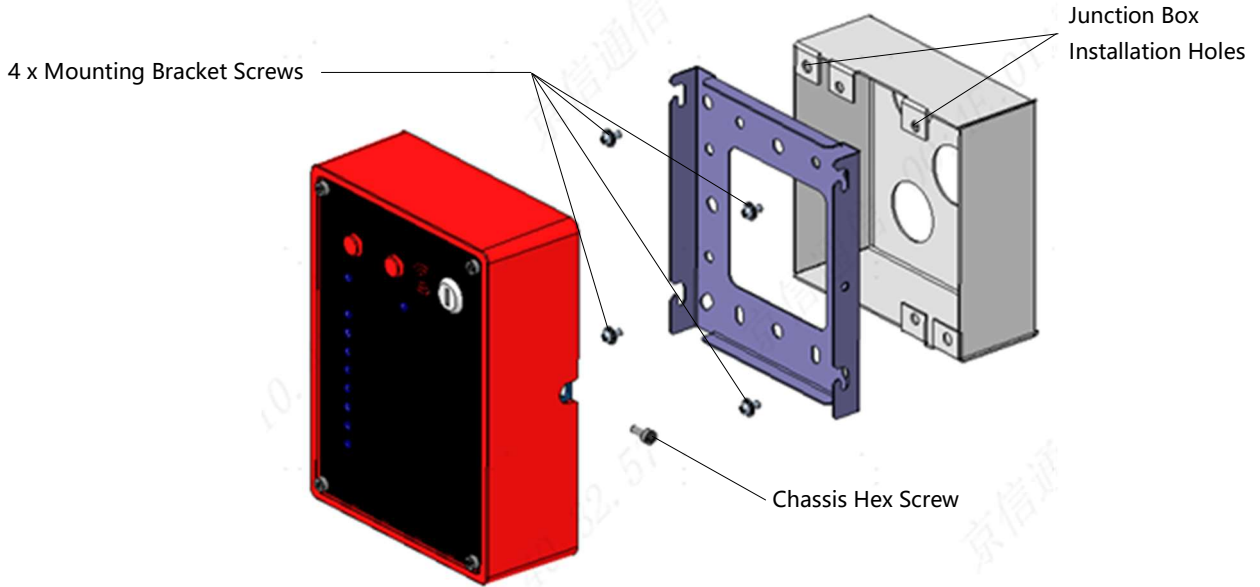

Figure 23: APV3-BDA – Mounting - Gang Box

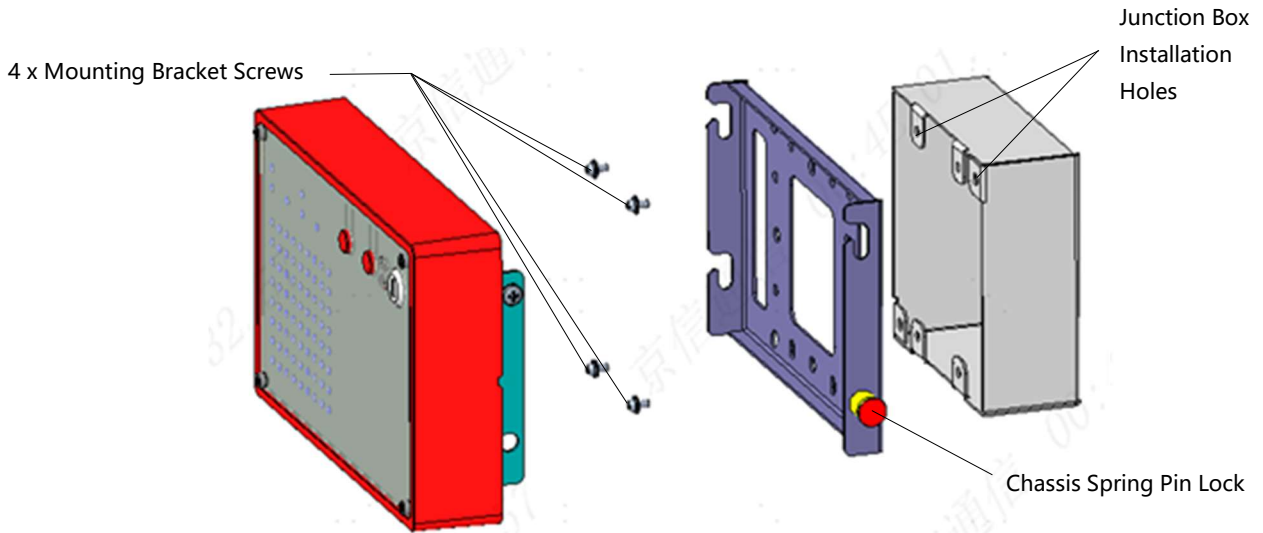

Figure 24: APV3-DAS - Mounting - Gang Box

2.10 V3 AP FLUSH MOUNTING

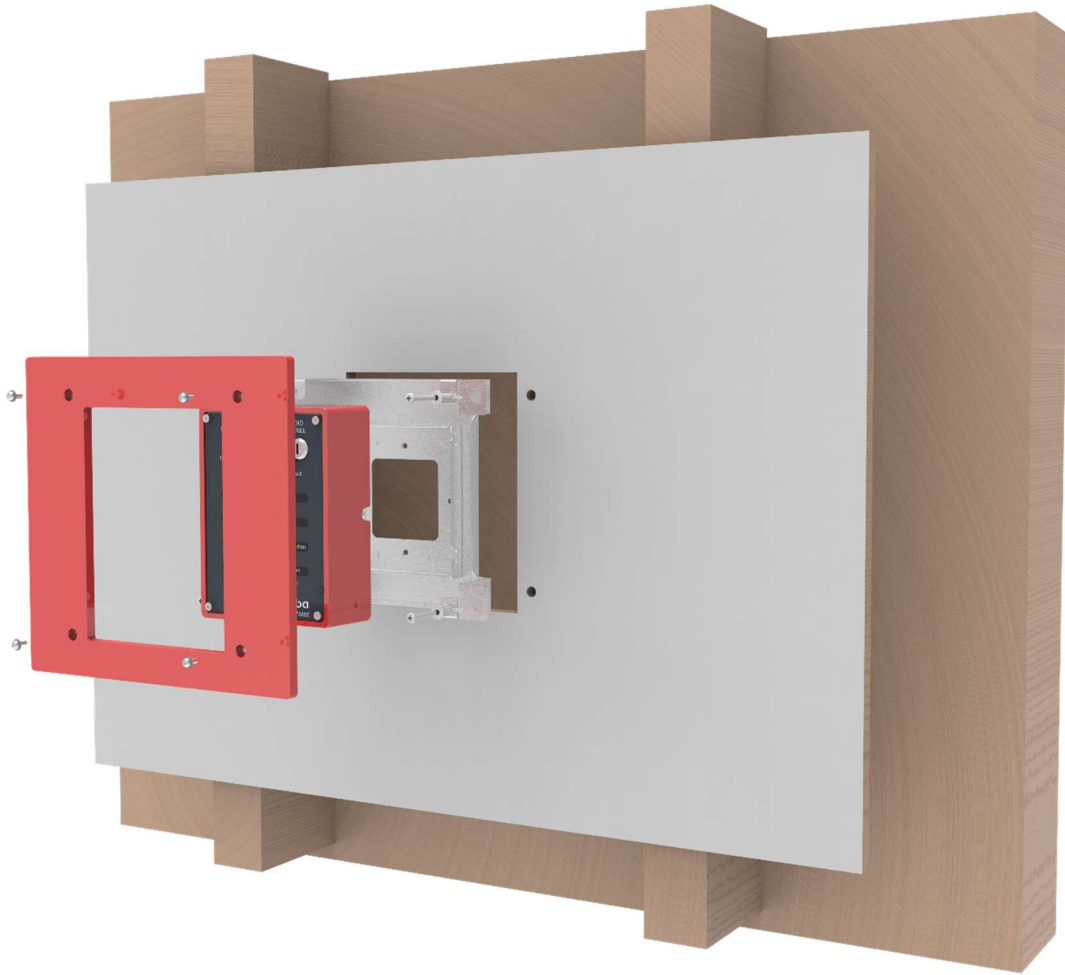

Figure 25: APV3-BDA - Flush Mounting to Wall

Follow the below instructions, Figures 26 through 29, to flush mount the APV3-BDA:

- Remove the APV3-BDA Flush Mount Kit from the box and place it on a flat surface with red face plate facing up.
- Remove the (4) Philips head screws holding the faceplate to the mounting bracket. Do not discard screws as these will be used to reinstall the face plate. Remove the face plate.
- Remove the (4) screws that are attached to the mounting bracket from the factory. These screws will be used in the next step to attach the APV3-BDA standard mounting bracket to the flush mount bracket. See figure 26 below.

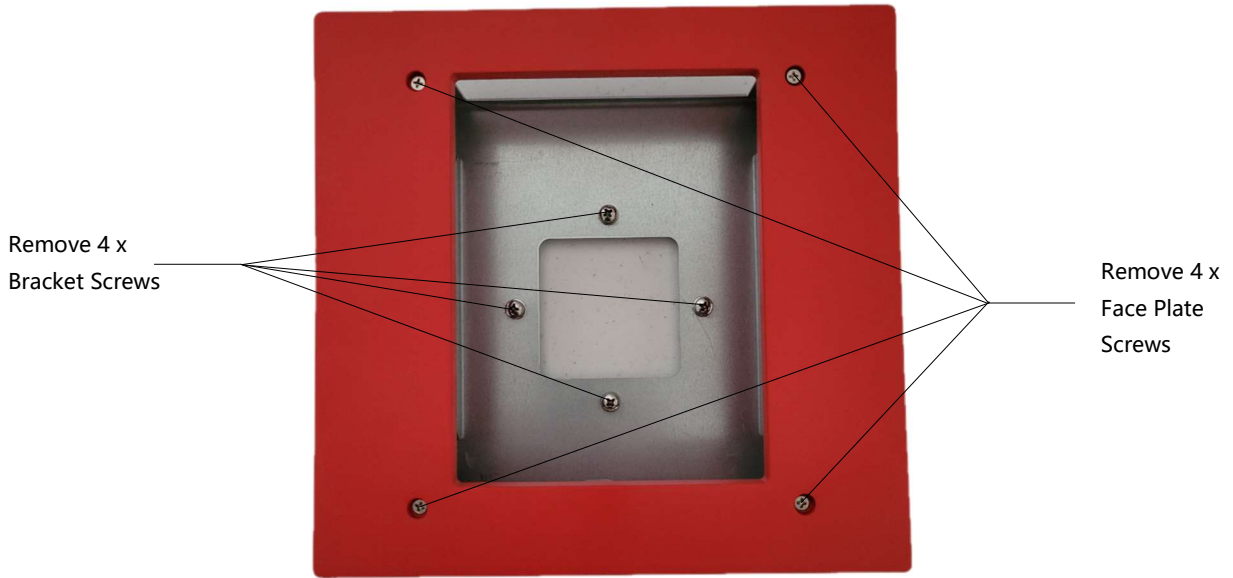

Figure 26: APV3-BDA - Flush Mount Kit Face Plate and Bracket Screw Removal

- Install the APV3-BDA standard mounting bracket into the flush mount bracket using the (4) screws removed in the previous step. Ensure the standard mounting bracket is installed with the HEX Screw hole on the right side. See figure 27 below.

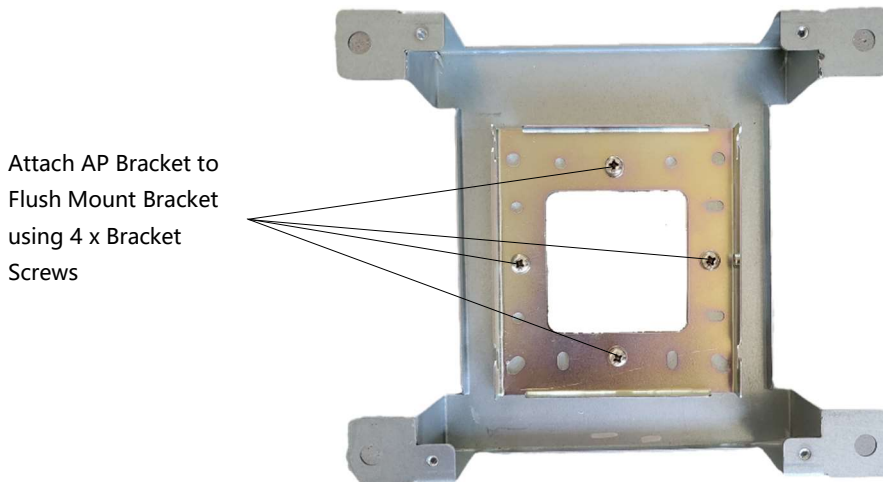

Figure 27: APV3-BDA - Mounting Standard Mounting Bracket to Flush Mount Bracket

CRITICALPOINT V3 AP USER MANUAL

- Align and hang the APV3-BDA cabinet onto the flush mounting bracket. Note, the Hex Screw that was removed earlier to release the standard mounting bracket from the AP is not used when flush mounting the APV3-BDA. You can simply hang the device onto the flush mount assembly. Refer to Figure 28 below.



Figure 28: APV3-BDA - Mounting APV3-BDA into Flush Mount Bracket

- Using the AP flush mounting bracket as a template, hold the bracket against the wall in the planned installation location. Using a pencil, trace the sides of the bracket to mark the rectangular location on the wall that needs to be cut out. Using a saw, cut out the rectangular section of drywall and remove.
- Push the AP mounting bracket into the rectangular area of removed drywall, so it fits flush and tight into the wall. If the rectangular area is too small to push the bracket into position, you may need to use sandpaper or another tool to slightly enlarge the rectangular opening.
- Once the AP and Flush Mount Bracket are in position, use a pencil to mark the location of the 4 holes that will need to be drilled to secure the flush mount bracket to the wall. After hole locations are marked, remove the AP and flush mount bracket from the wall.
- Drill four holes into the drywall using the previously marked locations. Install wall anchors as necessary.
- Connect the RJ45 ethernet cable to the V3 AP “PREV” port through the flush mount bracket.
- Push AP and flush mount bracket into the wall location.
- Use (4) screws to attach the flush mounting bracket to the wall. Screws and anchors are not provided.
- Install the flush mount front plate using the (4) provided screws.

CRITICALPOINT V3 AP USER MANUAL

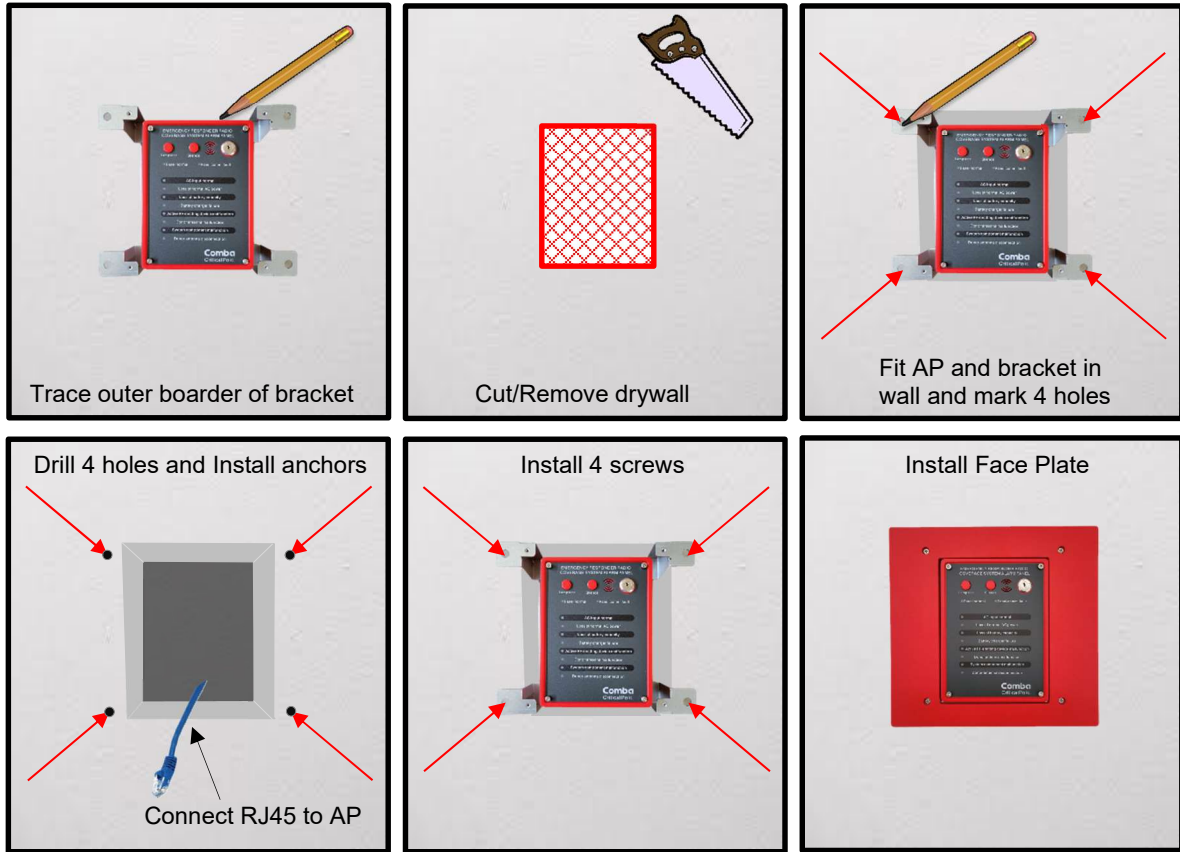

Figure 29: APV3-BDA - Installing Flush Mount Bracket, APV3-BDA, and Face Plate into a Wall

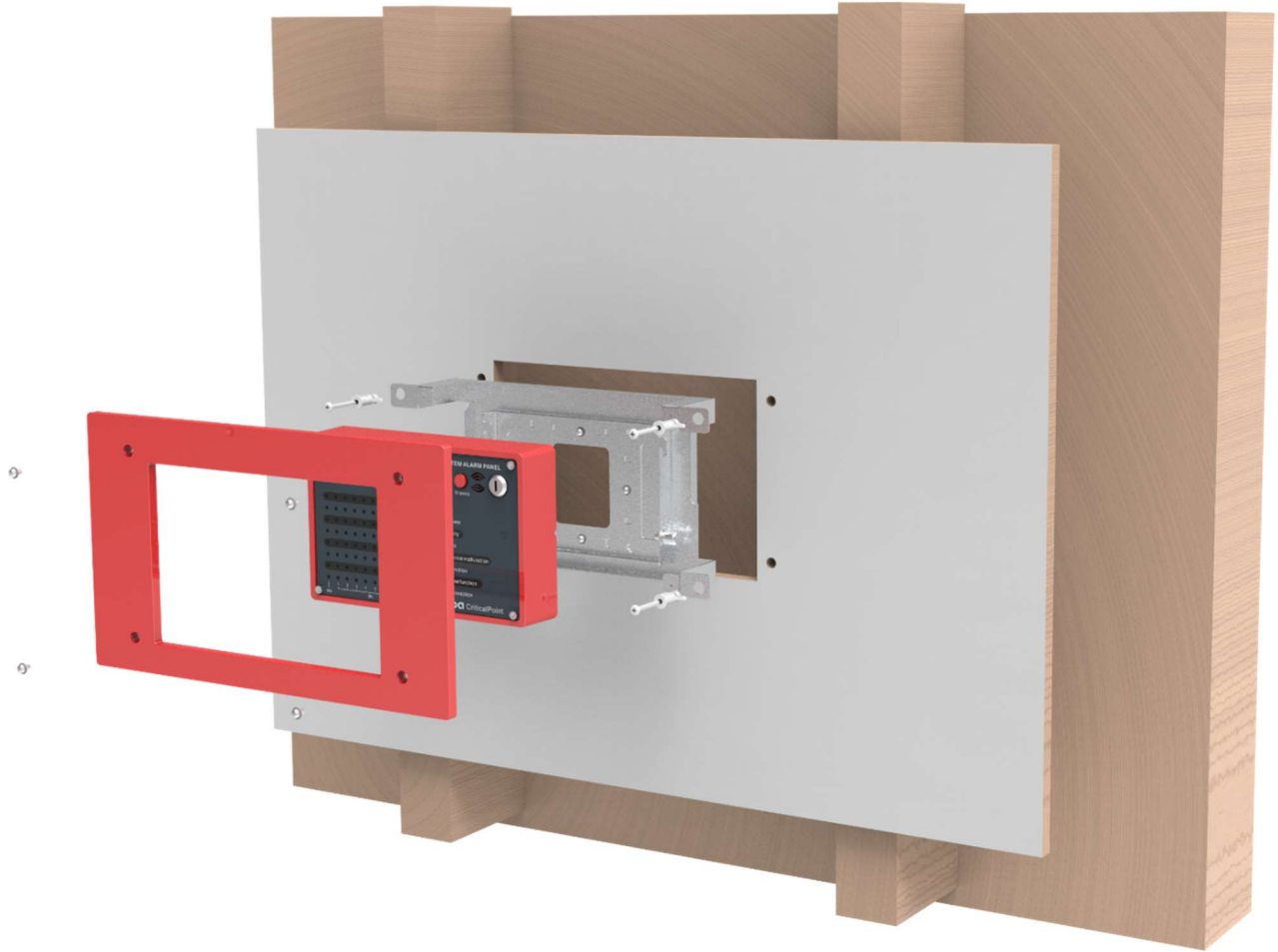

Figure 30: APV3-DAS - Flush Mounting to Wall

Follow the below instructions, Figures 31 through 234, to flush mount the APV3-DAS:

- Remove the APV3-DAS Flush Mount Kit from the box and place it on a flat surface with red face plate facing up.
- Remove the (4) Philips head screws holding the faceplate to the mounting bracket. Do not discard screws as these will be used to reinstall the face plate. Remove the face plate.
- Remove the (4) screws that are attached to the mounting bracket from the factory. These screws will be used in the next step to attach the APV3-DAS standard mounting bracket to the flush mount bracket. See figure 31 below.

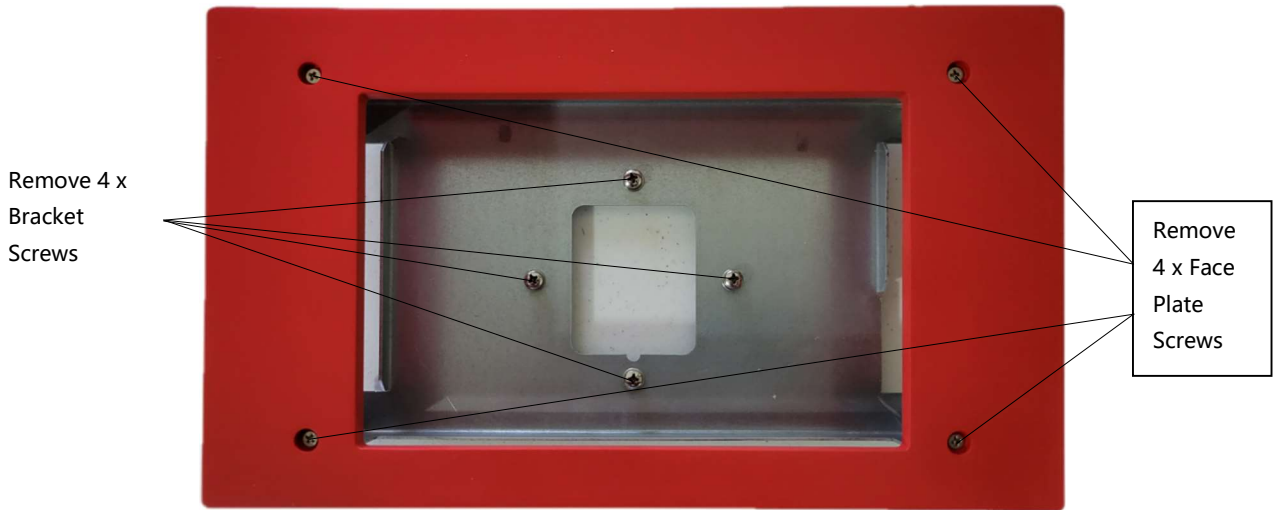

Figure 31: APV3-DAS - Flush Mount Kit Face Plate and Bracket Screw Removal

- Install the APV3-DAS standard mounting bracket into the flush mount bracket using the (4) screws removed in the previous step. Ensure the standard mounting bracket is installed with the Spring-loaded Pin Lock on the right side. See figure 32 below.

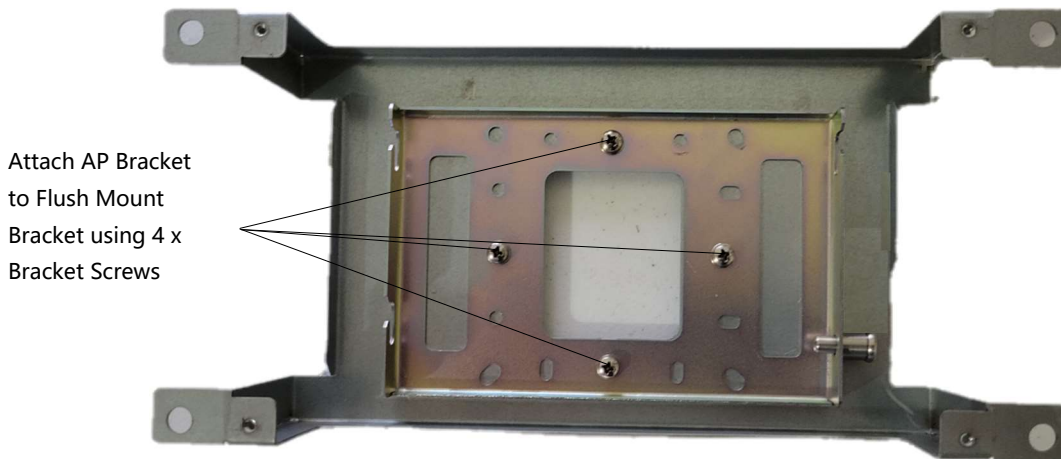

Figure 32: APV3-DAS - Mounting Standard Mounting Bracket to Flush Mount Bracket

CRITICALPOINT V3 AP USER MANUAL

- Align and hang the APV3-DAS cabinet onto the flush mounting bracket. You must pull out the spring-loaded pin lock, hang the AP cabinet, then release the pin lock.



Figure 33: APV3-DAS - Mounting APV3-DAS into Flush Mount Bracket

- Using the AP flush mounting bracket as a template, hold the bracket against the wall in the planned installation location. Using a pencil, trace the sides of the bracket to mark the rectangular location on the wall that needs to be cut out. Using a saw, cut out the rectangular section of drywall and remove.
- Push the AP mounting bracket into the rectangular area of removed drywall, so it fits flush and tight into the wall. If the rectangular area is too small to push the bracket into position, you may need to use sandpaper or another tool to slightly enlarge the rectangular opening.
- Once the AP and Flush Mount Bracket are in position, use a pencil to mark the location of the 4 holes that will need to be drilled to secure the flush mount bracket to the wall. After hole locations are marked, remove the AP and flush mount bracket from the wall.
- Drill four holes into the drywall using the previously marked locations. Install wall anchors as necessary.
- Connect the RJ45 ethernet cable to the AP "PREV" port through the flush mount bracket.
- Push AP and flush mount bracket into the wall location.
- Use (4) screws to attach the flush mounting bracket to the wall. Screws and anchors are not provided.
- Install the flush mount front plate using the (4) provided screws.

CRITICALPOINT V3 AP USER MANUAL

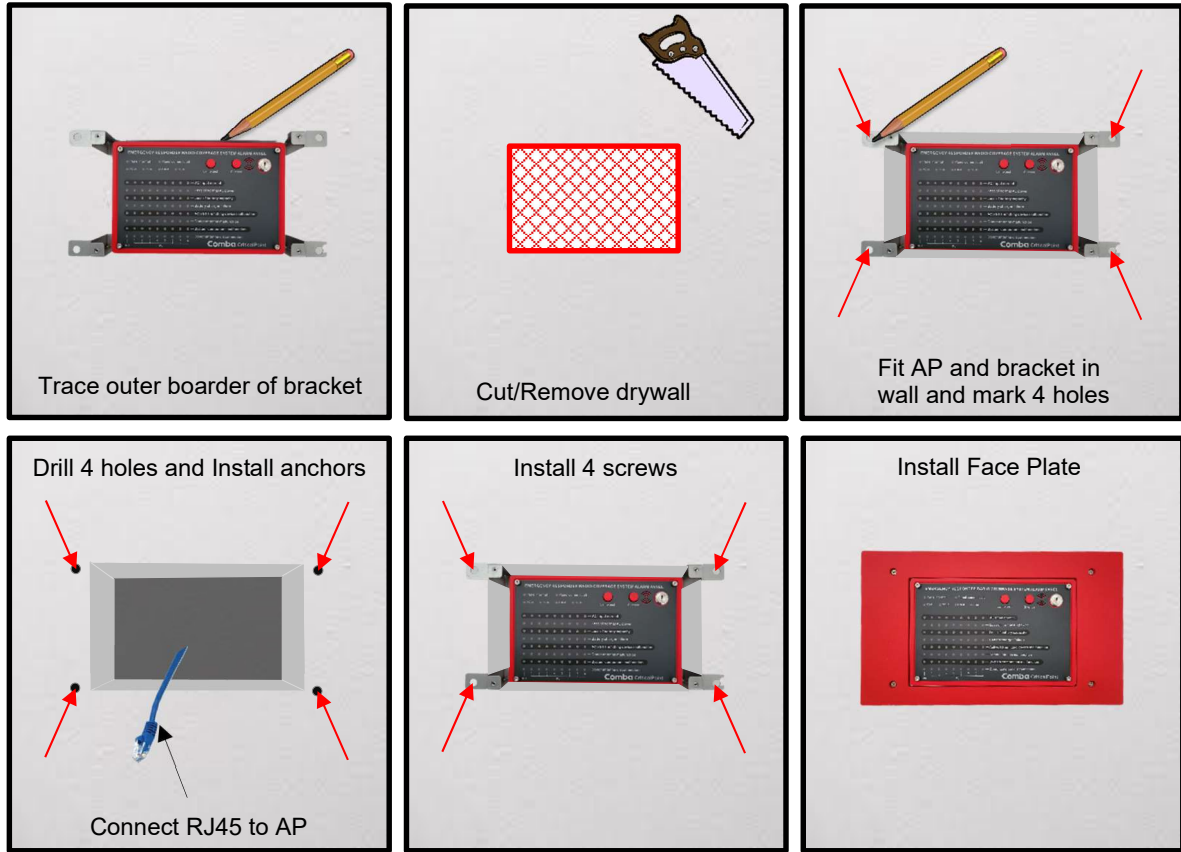

Figure 34: APV3-BDA - Installing Flush Mount Bracket, APV3-BDA, and Face Plate into a Wall

CRITICALPOINT V3 AP USER MANUAL



Figure 35: APV3-BDA and APV3-DAS Flush Mounted to Wall

2.11 V3 AP SYSTEM WIRING

The V3 AP Power and Communications wiring is not provided with the equipment and must be provided by the installer. The BDA/MU/RU connects to the V3 AP using T568B RJ45 network cable sequence. An adapter cable is provided to combine the BDA/MU/RU Power and Comms Outputs into an RJ45 female connector. This allows for a single run of cat 5/6 cable terminated with RJ45 connectors to be used in between the BDA/MU/RU and V3 APs. This adapter cable comes pre-terminated from the factory with phoenix connectors allowing for quick installation. See figure 36 diagram below.



ALERT: DO NOT use an ethernet crossover cable to connect between the BDA/MU/RU and V3 AP devices. The crossover cable DOES NOT support the power and RS-485 sequence and WILL cause damage to the devices.

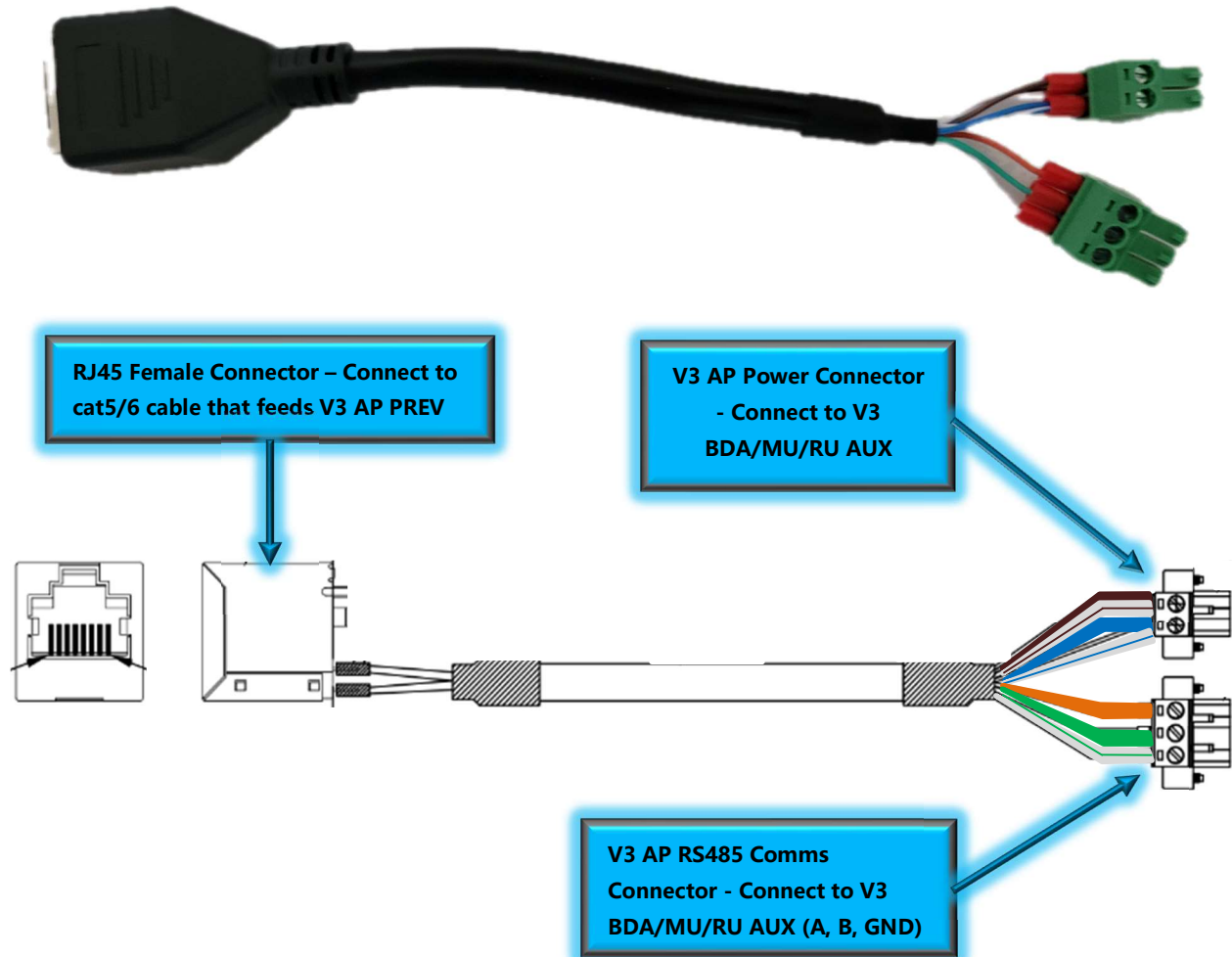

Figure 36: V3 BDA/MU/RU - RJ45 Adapter for V3 APs

CRITICALPOINT V3 AP USER MANUAL

Follow the below instructions, Figure 37 below, to connect a V3 AP to the V3 BDA/MU or RU:

- Power down the V3 BDA/MU or RU system.
- Connect the RJ45 adapter to the BDA/MU/RU as shown in the figure 37 below.
- Connect RJ45 ethernet cable between the RJ45 adapter and the V3 AP “PREV” port.
- To cascade additional APs, connect RJ45 cat5/6 cable between previous AP1 “NEXT” port and AP2 “PREV” port.

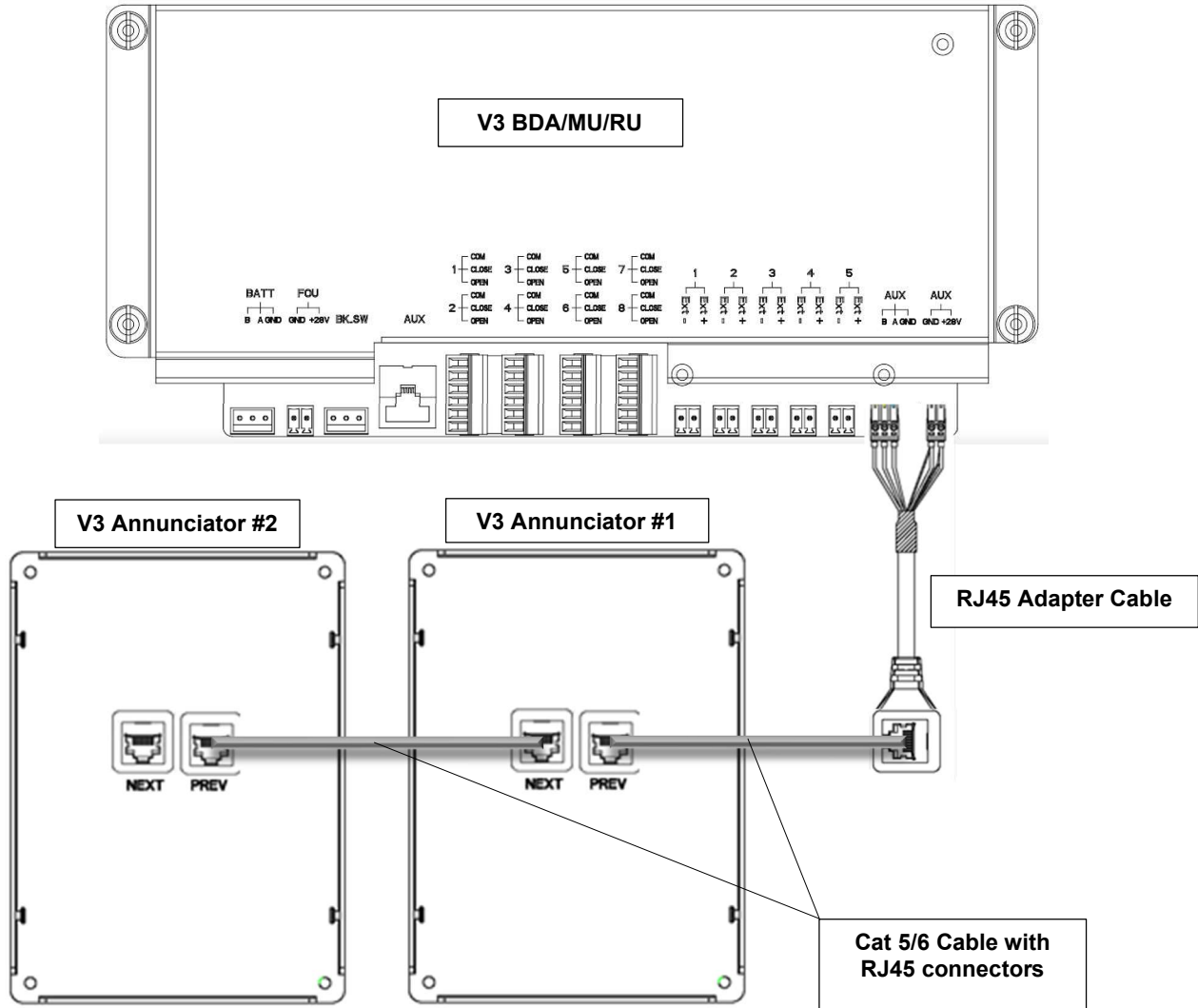

Figure 37: V3 BDA/MU/RU Wiring Connection to V3 AP



General Warning

Caution: You must follow your local code requirements for guidance on cable installation. See local codes for additional guidance on installing cabling inside of conduit as well as free wiring cable. Please ensure the correct liquid tight connector or cable gland is used.

2.12 V3 AP SYSTEM WIRING

Follow the below instructions, Figures 38

- Ensure all APs have been address
- Power down the V3 BDA/MU or
- Connect one end of an RJ45 cat
- Connect the opposite end of the
- Follow the same concept to casc

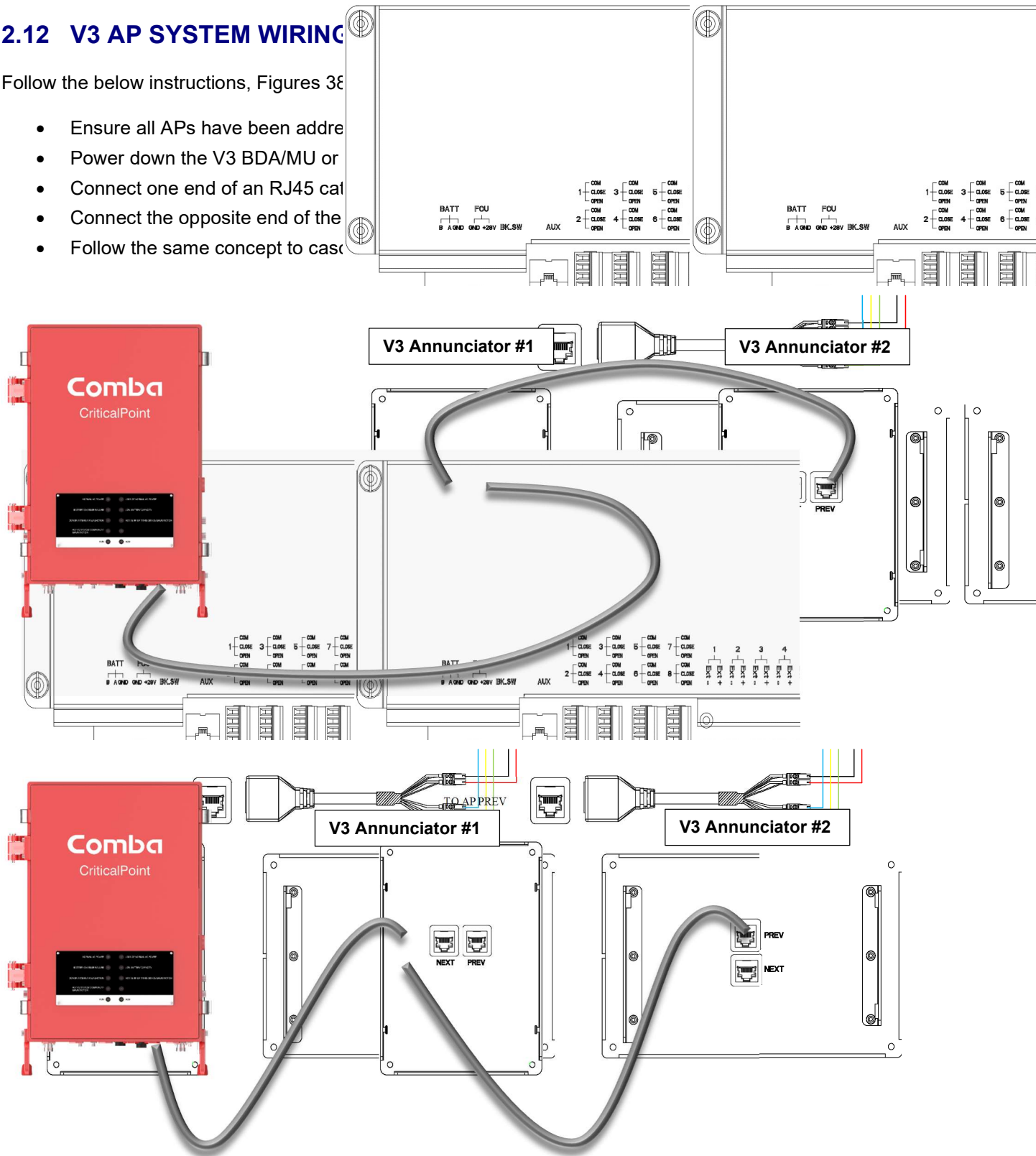

Figure 39: Cascading Multiple APV3-DAS

2.13 V3 AP SYSTEM WIRING – BARE WIRE CONNECTION TO BDA/MU/RU

In some cases, a technician may not want to use the RJ45 ethernet adapter and connect the cat 5/6 wires directly to the BDA/MU/RU equipment. In this case, you must use the T568B network cable sequence to make the connections. See Figure 40 below for details on the required T568B pin out and connection to BDA/MU/RU equipment.

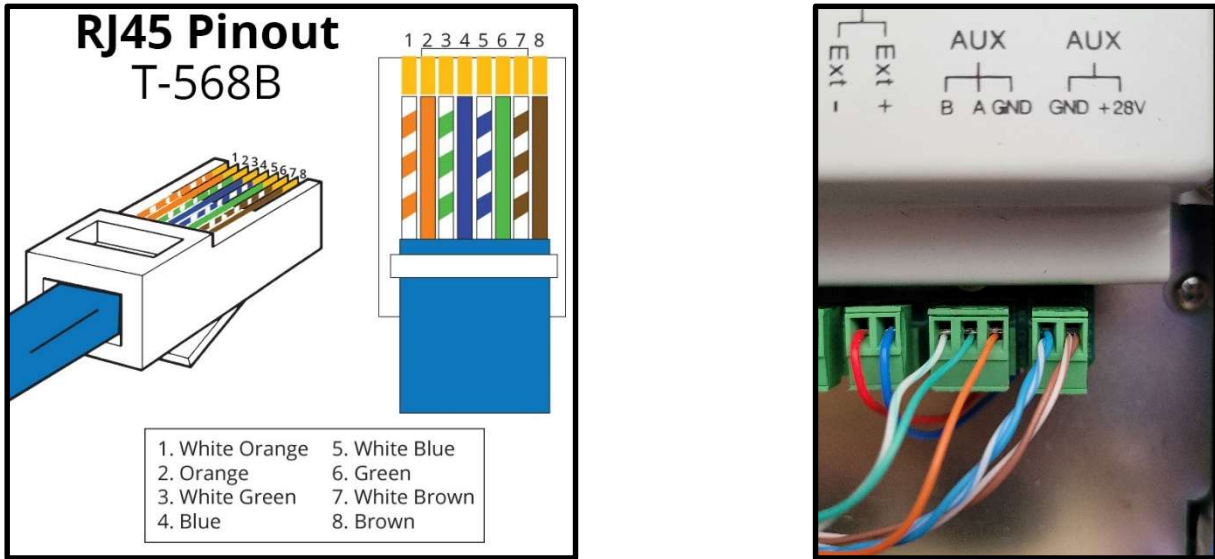

Figure 40: V3 AP - RJ45 T568B Connector Pinout for Bare Wire Connection to BDA/MU/RU

Follow the below instructions to connect V3 AP to a BDA/MU/RU using bare ethernet cat 5/6 wires:

- Power down the V3 BDA/MU or RU system.
- Connect one end of the cat 5/6 cable terminated with RJ45 to the “PREV” port of the AP.
- Connect the other end of the cat 5/6 cable with bare wires to BDA/MU/RU as follows:
 - White/Orange – NOT USED
 - Orange – Connect to AUX RS485 GND
 - White/Green – Connect to AUX RS485 B
 - Green – Connect to AUX RS485 A
 - White/Blue – Connect to AUX GND
 - Blue – Connect to AUX GND
 - White/Brown – Connect to AUX +28VDC
 - Brown – Connect to AUX +28VDC
- To cascade additional APs, connect RJ45 cat5/6 cable between previous AP “NEXT” port and the next AP “PREV” port. Connections between annunciators must be made using RJ45 connectors.

2.14 V3 BDA/MU/RU ANNUNCIATOR FRONT PLATE INSTALLATION

The V3 APs come from the factory with four different alarm plate options for the front of the device. This allows the user to choose the front panel plate that matches the authority's code requirements. The UL2524 2nd Revision Oct 2018 Alarm plate is installed in the factory.

To replace the factory installed plate:

- As shown in Figure 41 and 42 below, remove the 4 HEX screws holding the factory installed plate in place. This hardware will be reused. Do not discard!
- Position the desired plate such that all 4 cabinet screw holes are aligned with the holes in the new plate.
- Secure the plate using the 4 screws.



Figure 41: APV3-BDA - Front Alarm Plate Installation

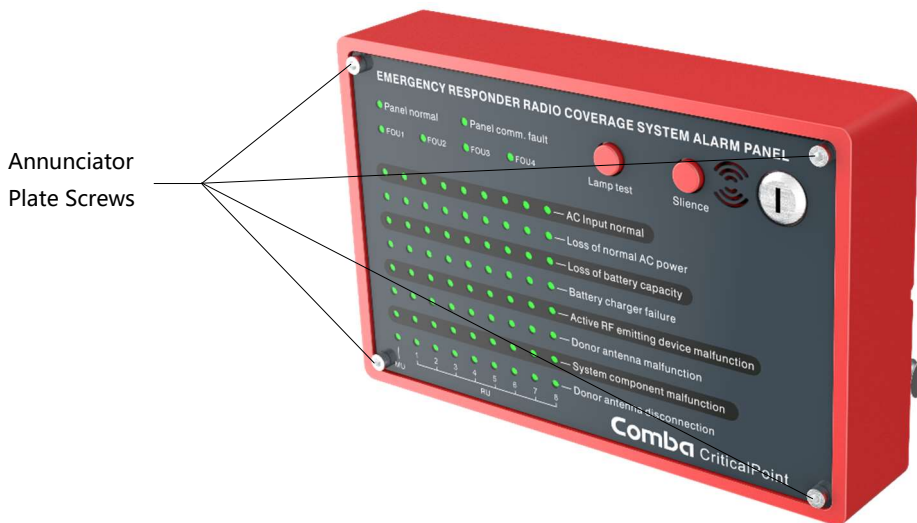

Figure 42: APV3-DAS - Front Alarm Plate Installation

CRITICALPOINT V3 AP USER MANUAL

See Table 3 below for details about the APV3-BDA front plate options and alarm configurations.

Table 3: APV3-BDA - Front Alarm Plate Options

Alarm Configuration	Annunciator Alarm LEDs	
UL2524 2 nd Rev Oct 2018 (Default)	<ol style="list-style-type: none"> 1. AC Input Normal 2. Loss of Normal AC Power 3. Loss of Battery Capacity 4. Battery Charger Failure 5. Active RF Emitting Device Malfunction 6. Donor Antenna Malfunction 7. System Component Malfunction 8. Donor Antenna Disconnection 9. Panel Normal 10. Panel Comm. Fault 	
NFPA1221 2019	<ol style="list-style-type: none"> 1. Normal AC Power 2. Loss of Normal AC Power 3. Battery Charger Failure 4. Low-Battery Capacity 5. Donor Antenna Malfunction 6. Active RF-Emitting Device Malfunction 7. Active System Component Malfunction 8. RUN 9. ALM 	
IFC510 2021	<ol style="list-style-type: none"> 1. Loss of Normal AC Power Supply 2. System Battery Charger(s) Failure 3. Malfunction of the Donor Antenna(s) 4. Failure of Active RF-Emitting Device(s) 5. Low-Battery Capacity at 70% Reduction of Operating Capacity 6. Failure of Critical System Components 7. ERRCS Annunciator Panel Communication Alarm 8. Oscillation of Active RF-Emitting Device 9. RUN 10. ALM 	
NFPA1225 2022	<ol style="list-style-type: none"> 1. Normal AC Power 2. Loss of Normal AC Power 3. Battery-Charger Failure 4. Low-Battery Capacity 5. Signal Source Malfunction 6. Active RF-Emitting Device Malfunction 7. Active System Component Failure 8. RUN 9. ALM 	

CRITICALPOINT V3 AP USER MANUAL

See Table 4 below for details about the APV3-DAS front plate options and alarm configurations.

Table 4: APV3-DAS - Front Alarm Plate Options

Alarm Configuration	Annunciator Alarm LEDs	
UL2524 2 nd Rev Oct 2018	<ol style="list-style-type: none"> AC Input Normal Loss of Normal AC Power Loss of Battery Capacity Battery Charger Failure Active RF Emitting Device Malfunction Donor Antenna Malfunction System Component Malfunction Donor Antenna Disconnection Panel Normal Panel Comm. Fault FOU Status Alarm 	
NFPA1221 2019 (Default)	<ol style="list-style-type: none"> Normal AC Power Loss of Normal AC Power Battery Charger Failure Low-Battery Capacity Donor Antenna Malfunction Active RF-Emitting Device Malfunction Active System Component Malfunction RUN ALM FOU Status Alarm 	
IFC510 2021	<ol style="list-style-type: none"> Loss of Normal AC Power Supply System Battery Charger(s) Failure Malfunction of the Donor Antenna(s) Failure of Active RF-Emitting Device(s) Low-Battery Capacity at 70% Reduction of Operating Capacity Failure of Critical System Components ERRCS Annunciator Panel Communication Alarm Oscillation of Active RF-Emitting Device RUN ALM FOU Status Alarm 	
NFPA1225 2022	<ol style="list-style-type: none"> Normal AC Power Loss of Normal AC Power Battery-Charger Failure Low-Battery Capacity Signal Source Malfunction Active RF-Emitting Device Malfunction Active System Component Failure RUN ALM FOU Status Alarm 	

End of Section

3 COMMISSIONING

3.1 PRE-COMMISSIONING TASKS

See Comba V3 BDA/BBU/DAS User Manual for instructions to follow to ensure system pre-commissioning tasks are complete before powering on the system.

3.2 V3 BDA/MU/RU/BBU POWER ON/POWER OFF

See Comba V3 BDA/BBU/DAS User Manual for instructions to follow to properly power ON/OFF the V3 system.

3.3 WEB GUI LOGIN AND USER MANAGEMENT

The PS BDA can be monitored and controlled via the WEB GUI; use the following instructions to login to the GUI for system parameter setting and commissioning.

BDA/MU or RU Login

- Set the computer IP address to 192.168.8.xxx (except 101) / 255.255.255.0. (e.g. 192.168.8.100)
- Connect the computer to the **OMT Port** on the device using a regular Ethernet RJ45 Cable.
- Use the default device IP address of **http://192.168.8.101** in the browser to login to the device. Enter full address with the <http://> all the time. Some browsers will default to use <https> and not be able to access the device if just typing 192.168.8.101.
- Use username **admin** and password **admin** for general web operation.
- There is an additional LAN port located on the BDA/MU only. The LAN port can be used for local access but more commonly used for remote access after being configured to connect to an external Modem / Router / Switch or a Gateway, etc...

The LAN port IP can be configured in WEB → Management → Network.

The LAN port default IP address is 192.168.0.101 / 255.255.255.0, and the Gateway is 192.168.0.1.

Note: If the device is configured for remote connection using the LAN port, all the firmware upgrades for the BDA/MU, FOU, and RUs can be completed remotely through the BDA/MU without the need to send anyone to the site.

3.4 WEB GUI INTRODUCTION

See Comba V3 BDA/BBU/DAS User Manual for complete overview of the V3 web GUI operation.

3.5 COMMISSIONING PROCEDURE

Perform the following procedures to commission the V3 AP. The process is the same for BDA, MU, or RU.

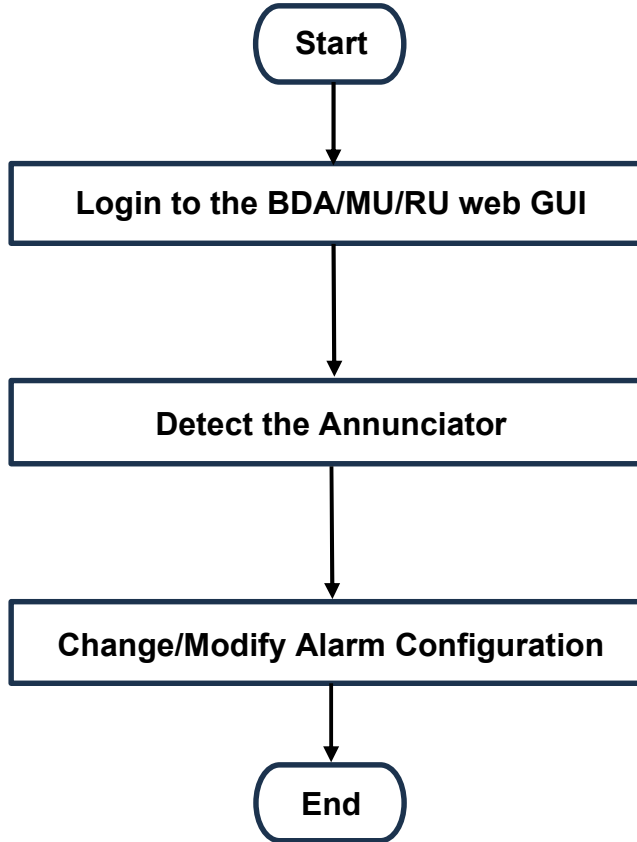

Figure 43: Commissioning Procedure

Follow the below instructions to commission the V3 AP(s):

- Ensure all installation and wiring is complete.
- Ensure APs have been addressed accordingly. See section 2.8 for more details
- Login to the BDA/MU/RU web GUI.
- For BDA mode, Figure 44 below, navigate to Device -> Overview -> External Annunciator Panel. For MU mode, Figure 45 below, navigate to Home -> MU -> AP. For RU, Navigate through the MU to Home -> RU -> AP.
- Click “detect” to start the detection process. Wait a few minutes for the AP(s) to be detected. After the AP(s) are detected, their system details will display in the GUI.
- If desired, modify alarm parameters in the “actions” column. Default settings are recommended.
- If required, change the alarm configuration to match the front panel alarm plate. See section 4 Alarms, Troubleshooting, and Maintenance for further details.

CRITICALPOINT V3 AP USER MANUAL

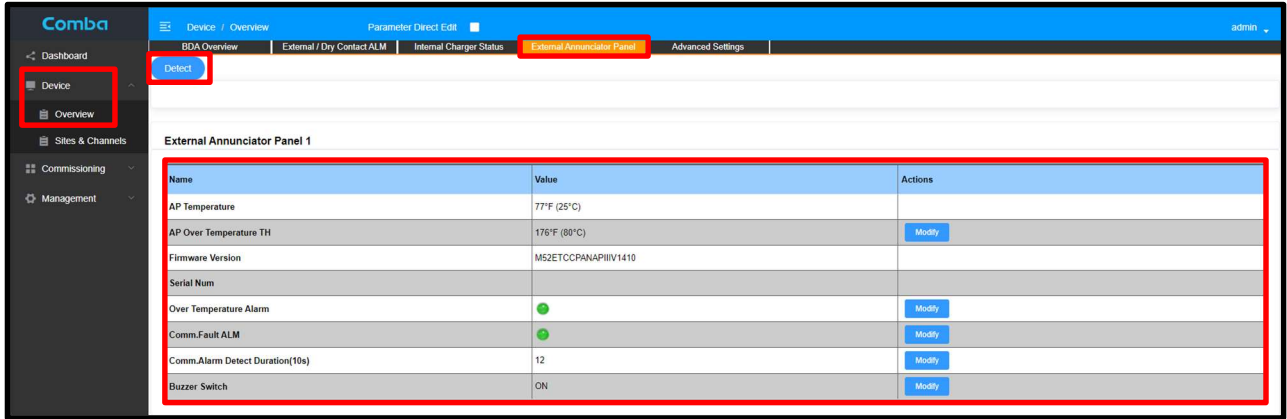

Figure 44: Commissioning V3 AP in BDA mode

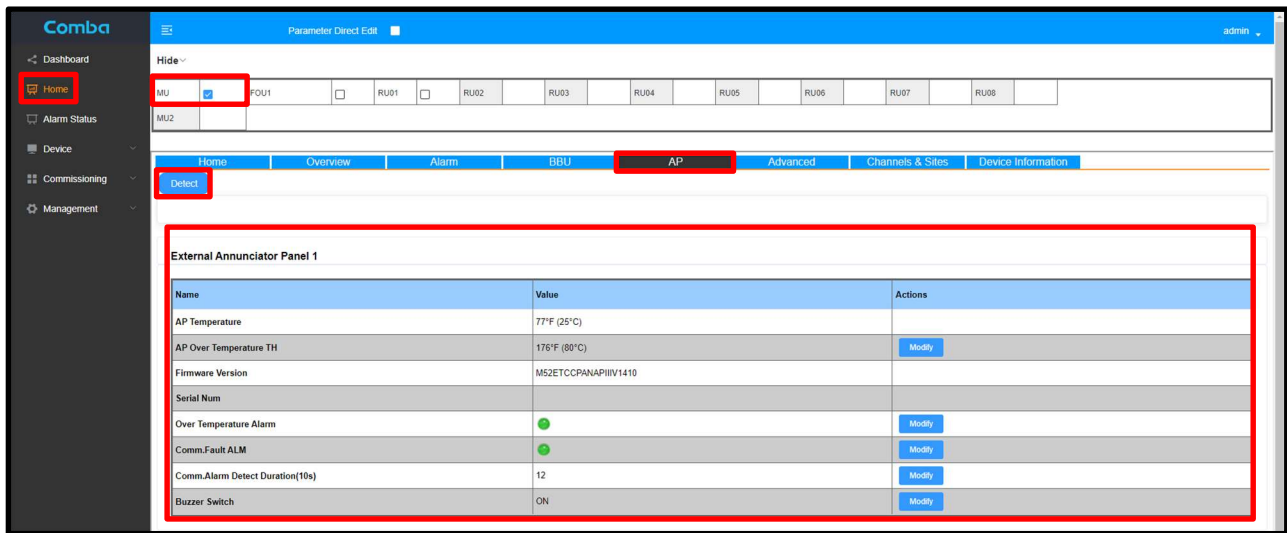

Figure 45: Commissioning V3 AP in DAS Mode

3.6 V3 AP – WEB GUI SETTINGS

See Figure 46 and Table 5 below for an explanation of AP web GUI parameters and settings

Name	Value	Actions
AP Temperature	77°F (25°C)	
AP Over Temperature TH	176°F (80°C)	Modify
Firmware Version	M52ETCCPANAPIIV1410	
Serial Num		
Over Temperature Alarm	●	Modify
Comm.Fault ALM	●	Modify
Comm.Alarm Detect Duration(10s)	12	Modify
Buzzer Switch	ON	Modify

Figure 46: V3 AP - Web GUI Settings

CRITICALPOINT V3 AP USER MANUAL

Table 5: V3 AP - Web GUI Settings

Parameter name	Description
AP Temperature	Current device temperature
AP Over Temperature Threshold	Device will alarm if above this temperature threshold. Modify if desired. Default setting recommended.
Firmware Version	Current Firmware Version loaded on the device
Serial Number	Device Serial Number
Overtemperature Alarm	Disable/Enable Overtemperature Alarm. Modify if desired. Default setting recommended.
Communication Fault Alarm	Disable/Enable Communication Fault Alarm. Modify if desired. Default setting recommended.
Communication Alarm Detection Duration(10s)	Allowable time without communication before Communication Fault Alarm. Set in Multiples of 10 seconds. The default setting is 12. 12 x 10 seconds = 120 seconds or 2 minutes
Buzzer Switch	Enable/Disable Buzzer. Modify if desired. Default setting recommended.

End of Section

4 ALARMS, TROUBLESHOOTING, AND MAINTENANCE

4.1 V3 AP ANNUNCIATOR LED INDICATORS, SILENCE AND LAMP TEST

The LED indicators help the user to check the equipment alarm status quickly and easily. See Figures 47 and 48, and Table 6 below for a detailed explanation of their operation.

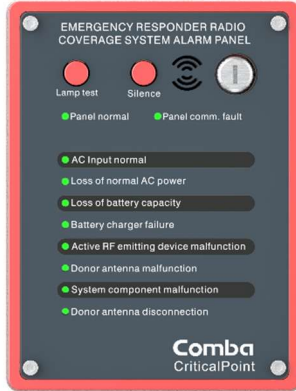

Figure 47: APV3-BDA - LED Alarm Indicators

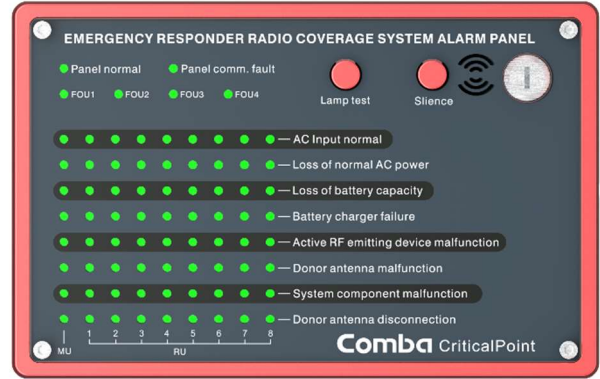

Figure 48: APV3-DAS - LED Alarm Indicators

Table 6: V3 AP - Default LED Indicators for UL2524 2018 2nd Revision

Identifier	Color	Indication
AC Input normal	Green/Red	When AC input is ok, GREEN. RED if in alarm.
Loss of normal AC power	Red	When AC input is not present, ON
Loss of battery capacity	Red	When battery voltage is lower than the threshold, ON
Battery charger failure	Red	When AC/DC module detects fault, ON
Active RF emitting device malfunction	Red	When the Public safety product generates Booster failure alarm event, ON
Donor antenna disconnection	Red	When the Public safety product generates Donor Antenna Disconnection alarm, ON
System component malfunction	Red	When the Public safety product generates System Component alarm, ON
Donor antenna malfunction	Red	When the Public safety product generates Donor Antenna malfunction alarm, ON
Panel Comm. Fault	Red	When the communication between Alarm panel and BBU unit is abnormal, ON
Panel Normal	Green	When Alarm panel works normally, ON
FOU1~FOU4	Green	Indicates that the alarm display panel displays alarms for a specific FOU. When FOU detected, ON <i>*For APV3-DAS only</i>
Lamp Test	N/A	Press the panel lamp test button to perform a lamp self-check when the key switch is on.
Silence	N/A	Mute button, which can turn off the buzzer sound when the key switch is on

CRITICALPOINT V3 AP USER MANUAL

There are multiple alarm presets in the BDA/MU/RU web GUI provided so the user can quickly configure alarms for their jurisdiction's code requirements. The AP's are provided with matching front panel alarm plates based on the BDA/MU/RU presets. Furthermore, the user can define their own set of custom alarms for each Dry Contact Output. As previously shown, the UL2524 2018 is the default preset from the factory. Figures 49 and 50, and Table 7, indicate the general relationship between dry contact settings and LED alarm annunciation.



Figure 49: APV3-BDA - LED and Dry Contact Alarm Correlation

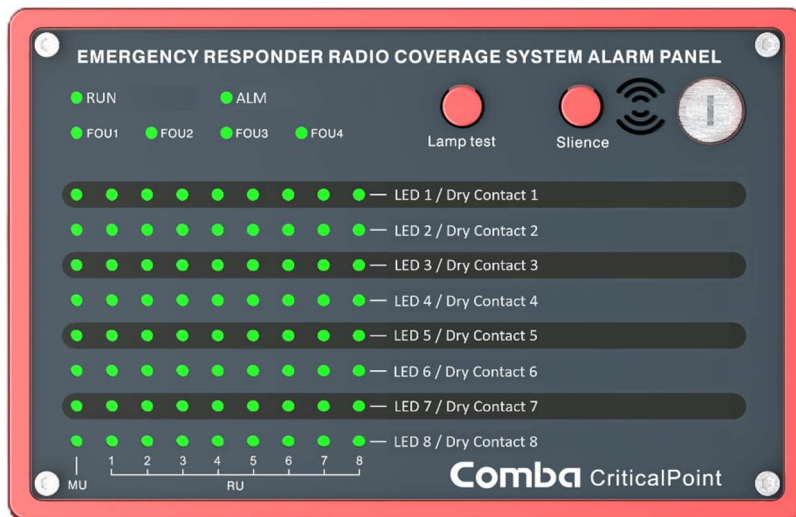

Figure 50: APV3-DAS - LED and Dry Contact Alarm Correlation

CRITICALPOINT V3 AP USER MANUAL

Table 7: V3 AP - LED Indicators – General Overview

Identifier	Color	Indication
LED 1 / Dry Contact 1	Green/Red	Green=Normal; Red=Alarm (AC Power Alarm)
LED 2 / Dry Contact 2	Red	Alarm indicator. ON = alarm; OFF = no alarm.
LED 3 / Dry Contact 3	Red	Alarm indicator. ON = alarm; OFF = no alarm.
LED 4 / Dry Contact 4	Red	Alarm indicator. ON = alarm; OFF = no alarm.
LED 5 / Dry Contact 5	Red	Alarm indicator. ON = alarm; OFF = no alarm.
LED 6 / Dry Contact 6	Red	Alarm indicator. ON = alarm; OFF = no alarm.
LED 7 / Dry Contact 7	Red	Alarm indicator. ON = alarm; OFF = no alarm.
LED 8 / Dry Contact 8	Red	Alarm indicator. ON = alarm; OFF = no alarm.
RUN	Red	Operation indicator. Flashes every second to indicate normal operation. 1. OFF: MCU cannot be powered up 2. Solid RED: Software is not ready / cannot boot up 3. Solid Green: Software is running normally 4. Green (1 blink, pause): Not commissioned 5. Green (2 blink, pause): RR Switches are both off
ALM	Red	Alarm indicator. ON = alarm; OFF = no alarm. 1. OFF: No Alarm 2. Solid Red: Dry Contact 1-8 active 3. Red (1 blink, pause): Any other alarms besides Dry Contact configured alarms.
FOU1~FOU4	Green	Indicates that the alarm display panel displays alarms for a specific FOU. *For APV3-DAS only
Lamp Test	N/A	Press the panel lamp test button to perform a lamp self- check when the key switch is on.
Silence	N/A	Mute button, which can turn off the buzzer sound when the key switch is on

4.2 ALARM STATUS INDICATORS IN THE WEB GUI

Tables 8 and 9 below describes where the alarm conditions can be found in the V3 BDA/MU/RU devices

Table 8: V3 BDA/MU/RU - Web GUI Alarm Status Indicators

Parameter name	Description
Home page	View of all dry contact alarm status. View of all current system alarms.
Device – Overview Page – Overview Tab	General device alarm status. 700MH/800MHz band specific alarm status
Device – Overview Page – External/Dry Contact ALM Tab	External Alarms Dry Contact Alarms
Device – Overview Page – Internal Charger Status	Power Supply and Battery Charger status and alarms.
Device – Overview – External Annunciator Panel	Comba External Annunciator Panel V1 status and alarms.
Device – Overview – Advanced Settings	Settings for Oscillation Alarm and Antenna Disconnection Alarm.

CRITICALPOINT V3 AP USER MANUAL

Table 9: V3 BDA/MU/RU - Complete List of Device Alarms

(A)	(B)	Individual Alarms (C)	Related Bands / Modules / Devices
Summary Alarm	Dry Contact Alarm 1-8	P_in Low Alarm	DL 700MHz, DL 800MHz
		P_out Low Alarm	DL 700MHz, DL 800MHz
		P_in Over Alarm	DL 700MHz, DL 800MHz
		P_out Over Alarm	DL 700MHz, DL 800MHz, UL 700/800MHz
		LNA Alarm	DL 700MHz, DL 800MHz, UL 700/800MHz
		PA Alarm	DL 700MHz, DL 800MHz, UL 700/800MHz
		PA Shutdown Alarm	DL 700MHz, DL 800MHz, UL 700/800MHz
		VSWR Alarm	DL 700MHz, DL 800MHz
		Oscillation Shutdown Alarm	700MHz, 800MHz, hidden when the feature is OFF
		Oscillation Gain Reduction Alarm	700MHz, 800MHz, hidden when the feature is OFF
		Digital Clock Lock Alarm	Device
		DT ANT Disconnection Alarm	Device
		Over Temperature Alarm	Device
		External Alarms 1-4	Device
		External Alarm 5	Device / Preconfigured as Door Open Alarm
		Loss Of Normal AC Power	BBU, hidden when not using BBU V3
		Battery Low Alarm	BBU, hidden when not using BBU V3
		Charger Fault Alarm	BBU, hidden when not using BBU V3
		Battery Over-Discharge Alarm	BBU, hidden when not using BBU V3
		Battery Over Temperature Alarm	BBU, hidden when not using BBU V3
		Battery Connection Fail Alarm	BBU, hidden when not using BBU V3
		Battery Comm. Fault Alarm	BBU, hidden when not using BBU V3
		Charger Comm. Fault Alarm	BBU, hidden when not using BBU V3
		AP 1 Comm. Fault Alarm	Comba AP 1, hidden when no AP is connected
		AP 2 Comm. Fault Alarm	Comba AP 2, hidden when no AP is connected
		AP 3 Comm. Fault Alarm	Comba AP 3, hidden when no AP is connected
		AP 4 Comm. Fault Alarm	Comba AP 4, hidden when no AP is connected

Relationships between different alarms:

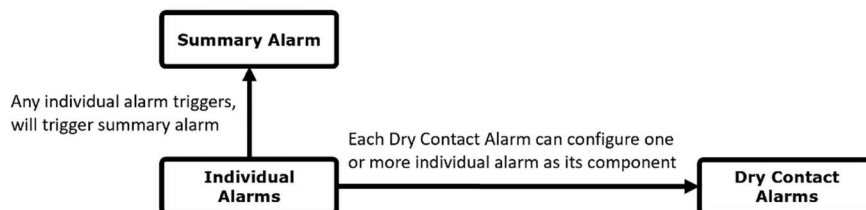

4.3 DRY-CONTACT AND AP ALARM SETTINGS

The Dry Contact Alarm and External Alarm settings can be found in the BDA/MU/RU web GUI.

Note: The V3 APs DO NOT have any Dry Contact Outputs. However, their LEDs mirror the Dry Contact Alarm configuration.

Navigate to Device → Overview → External/Dry Contact ALM

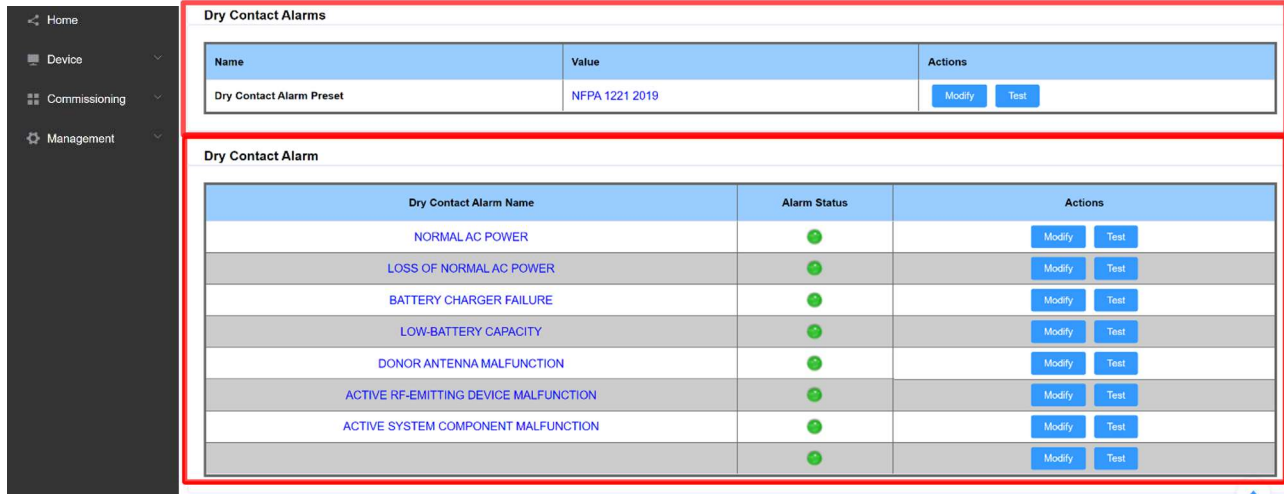

Figure 51: V3 BDA/MU/RU - Dry Contact and AP Alarm Setup through web GUI

There is multiple alarm preset options in the BDA/MU/RU web GUI so the user can easily configure alarms for the local jurisdiction code requirements, see above Figure 51 for reference. The BDA/MU/RU and AP have replaceable alarm indicator plates that match the software alarm presets. These alarm plates are included in the device accessory kits. Furthermore, the user can define their own set of custom alarms for each Dry Contact Output. As previously shown, the UL2524 2018 is the default preset from the factory. Refer to Table 10 below describing the available alarm presets.

Table 10: V3 BDA/MU/RU - Dry Contact and AP LED Alarm Presets

Dry Contact/AP LED Alarm Preset	Description
UL2524 Oct 2018 (DEFAULT)	Sets Dry Contacts and AP LEDs to meet UL2524 2 nd Revision standard
NFPA 1221 2019	Sets Dry Contacts and AP LEDs to meet NFPA 1221 2019 standard
NFPA 1225 2022	Sets Dry Contacts and AP LEDs to meet NFPA 1225 2022 standard
IFC 510 2021	Sets Dry Contacts and AP LEDs to meet IFC 510 2021 standard
User Defined	Custom configuration for custom alarm requirements. User can set the specific internal device alarms for each Dry Contact

CRITICALPOINT V3 AP USER MANUAL

Dry contact alarms 1 through 8 and AP LED's 1 through 8 are configured according to these standard presets and the APs will display the alarms accordingly. See Tables 11 through 14 below that describes each Dry Contact/AP LED preset configuration and the associated internal system alarms that are configured to trigger them.

Table 11: NFPA 1221 2019 Alarm Preset Dry Contact and LED Operation

LED/Dry Contact	NFPA 1221 2019	Default Alarm Configuration
1	NORMAL AC POWER	AC Normal
2	LOSS OF NORMAL AC POWER	AC Lost Alarm
3	BATTERY CHARGER FAILURE	Charger Fault Alarm Charger Comm. Fault Alarm
4	LOW-BATTERY CAPACITY	Battery Low Alarm Battery Connection Fail Alarm Battery Over Temperature Alarm Battery Comm. Fault Alarm Battery Over Discharge Alarm
5	DONOR ANTENNA MALFUNCTION	DT ANT Disconnection Alarm
6	ACTIVE RF-EMITTING DEVICE MALFUNCTION	PA Alarm 700/800 DL/UL DL P_in Over Alarm 700/800 DL DL P_out Over Alarm 700/800 DL LNA Alarm 700/800 DL/UL Oscillation Shutdown Alarm Gain Reduction Alarm PLL Alarm Digital Clock Alarm VSWR Alarm DL 700/800 Over Temperature Alarm
7	ACTIVE SYSTEM COMPONENT MALFUNCTION	Same as "ACTIVE RF-EMITTING DEVICE MALFUNCTION"
8	Blank	Blank

CRITICALPOINT V3 AP USER MANUAL

Table 12: UL2524 Oct 2018 Alarm Preset Dry Contact and LED Operation

LED/Dry Contact	UL2524 OCT 19 2018	Default Alarm Configuration
1	NORMAL AC POWER	AC Normal
2	LOSS OF NORMAL AC POWER	AC Lost Alarm
3	BATTERY CHARGER FAILURE	Charger Fault Alarm Charger Comm. Fault Alarm
4	LOSS OF BATTERY CAPACITY	Battery Low Alarm Battery Connection Fail Alarm Battery Over Temperature Alarm Battery Comm. Fault Alarm Battery Over Discharge Alarm
5	DONOR ANTENNA DISCONNECTION	DT ANT Disconnection Alarm
6	ACTIVE RF-EMITTING DEVICE MALFUNCTION	PA Alarm 700/800 DL/UL DL P_in Over Alarm 700/800 DL DL P_out Over Alarm 700/800 DL LNA Alarm 700/800 DL/UL Oscillation Shutdown Alarm Gain Reduction Alarm PLL Alarm Digital Clock Alarm VSWR Alarm DL 700/800 Over Temperature Alarm
7	ACTIVE SYSTEM COMPONENT MALFUNCTION	Same as "ACTIVE RF-EMITTING DEVICE MALFUNCTION"
8	DONOR ANTENNA MALFUNCTION	DT ANT Disconnection Alarm

CRITICALPOINT V3 AP USER MANUAL

Table 13: NFPA 1225 2022 Alarm Preset Dry Contact and LED Operation

LED/Dry Contact	NFPA 1225 2022	Default Alarm Configuration
1	NORMAL AC POWER	AC Normal
2	LOSS OF NORMAL AC POWER	AC Lost Alarm
3	BATTERY CHARGER FAILURE	Charger Fault Alarm Charger Comm. Fault Alarm
4	LOW-BATTERY CAPACITY	Battery Low Alarm Battery Connection Fail Alarm Battery Over Temperature Alarm Battery Comm. Fault Alarm Battery Over Discharge Alarm
5	SIGNAL SOURCE MALFUNCTION	DT ANT Disconnection Alarm
6	ACTIVE RF-EMITTING DEVICE MALFUNCTION	PA Alarm 700/800 DL/UL DL P_in Over Alarm 700/800 DL DL P_out Over Alarm 700/800 DL LNA Alarm 700/800 DL/UL Oscillation Shutdown Alarm Gain Reduction Alarm PLL Alarm Digital Clock Alarm VSWR Alarm DL 700/800 Over Temperature Alarm
7	ACTIVE SYSTEM COMPONENT MALFUNCTION	Same as "ACTIVE RF-EMITTING DEVICE MALFUNCTION"
8	Blank	Blank

CRITICALPOINT V3 AP USER MANUAL

Table 14: IFC 510 2021 Alarm Preset Dry Contact and LED Operation

LED/Dry Contact	IFC 510 2021	Default Alarm Configuration
1	LOSS OF NORMAL AC POWER SUPPLY	AC Lost Alarm
2	SYSTEM BATTERY CHARGER(S) FAILURE	Charger Fault Alarm Charger Comm. Fault Alarm
3	MALFUNCTION OF THE DONOR ANTENNA(S)	DT ANT Disconnection Alarm
4	FAILURE OF ACTIVE RF-EMITTING DEVICE(S)	PA Alarm 700/800 DL/UL DL P_in Over Alarm 700/800 DL DL P_out Over Alarm 700/800 DL LNA Alarm 700/800 DL/UL Oscillation Shutdown Alarm Gain Reduction Alarm PLL Alarm Digital Clock Alarm VSWR Alarm DL 700/800 Over Temperature Alarm
5	LOW-BATTERY CAPACITY AT 70% REDUCTION OF OPERATING CAPACITY	Battery Low Alarm Battery Connection Fail Alarm Battery Over Temperature Alarm Battery Comm. Fault Alarm Battery Over Discharge Alarm
6	FAILURE OF CRITICAL SYSTEM COMPONENTS	Same as "FAILURE OF ACTIVE RF-EMITTING DEVICE(S)"
7	ERRCS ANNUNCIATOR PANEL COMMUNICATION ALARM	AP Comm. Fault Alarm 1 AP Comm. Fault Alarm 2
8	OSCILLATION OF ACTIVE RF-EMITTING DEVICE	Oscillation Shutdown Alarm Gain Reduction Alarm

4.4 USER DEFINED DRY CONTACT AND LED ALARM CONFIGURATION

In some cases, the user may require using an alarm configuration that is not consistent with one of the available alarm presets. For the user to customize Dry Contact and LED alarm operation, they must access the web GUI and choose the “User Defined” option in the device Dry Contact preset dropdown. Once this option has been selected, the user can change the Dry Contact alarm name and configurations from the settings table. Each Dry Contact alarm can now be custom named and configured to trigger upon any system alarm the user chooses.

Figures 52 and 53 below are examples of how to configure a “User Defined” alarm option. In the BDA/MU/RU, navigate to Device → Overview → External/Dry Contact ALM → Dry Contact Alarm Preset → Modify → User Defined

Dry Contact Alarm Name	Alarm Status	Actions
NORMAL AC POWER	●	Modify Test
LOSS OF NORMAL AC POWER	●	Modify Test
BATTERY CHARGER FAILURE	●	Modify Test
LOW-BATTERY CAPACITY	●	Modify Test
DONOR ANTENNA MALFUNCTION	●	Modify Test
ACTIVE RF-EMITTING DEVICE MALFUNCTION	●	Modify Test
ACTIVE SYSTEM COMPONENT MALFUNCTION	●	Modify Test

Figure 52: V3 BDA/MU/RU - User Defined Dry Contact Alarm Window

Click on “Modify” to select one or more internal system alarms to trigger a specific Dry Contact and LED alarm

Alarm name: NORMAL AC POWER

Select all

- AC Normal
- AC Lost Alarm
- Charger Fault Alarm
- Charger Comm. Fault Alarm
- PA Alarm DL 700MHz
- LNA Alarm DL 700MHz
- PA Shutdown Alarm DL 700MHz
- Ext Alarm 1
- PA Alarm DL 800MHz
- LNA Alarm DL 800MHz
- PA Shutdown Alarm DL 800MHz
- Ext Alarm 2
- PA Alarm UL 700&800MHz
- LNA Alarm UL 700&800MHz
- PA Shutdown Alarm UL 700&800MHz
- Ext Alarm 3
- DL P_in Over Alarm 700MHz
- DL P_in Low Alarm 700MHz
- Oscillation Shutdown Alarm
- Ext Alarm 4
- DL P_out Over Alarm 700MHz
- DL P_out Low Alarm 700MHz
- Oscillation Gain Reduction Alarm
- Ext Alarm 5
- DL P_in Over Alarm 800MHz
- DL P_in Low Alarm 800MHz
- PLL Alarm
- Over Temperature Alarm
- DL P_out Over Alarm 800MHz
- DL P_out Low Alarm 800MHz
- Digital Clock Alarm
- DT ANT Disconnection Alarm
- VSWR Alarm DL 700MHz
- VSWR Alarm DL 800MHz
- Battery Low Alarm
- Battery Connection Fail Alarm
- Battery Over Temperature Alarm
- Battery Comm. Fault Alarm
- Battery Over-Discharge Alarm

Figure 53: V3 BDA/MU/RU - User Defined Dry Contact System Alarms

4.5 EXTERNAL ALARMS

In some cases, the user may require incorporating external device alarms into the DAS solution and have them monitored at the FACP and displayed on the AP. An example would be a third-party bias-T system required to monitor a donor antenna or a room high-temp alarm. These third-party device alarm outputs can be connected to an external alarm input of the BDA/MU/RU device for the purpose of monitoring and sending out an alarm. Once an external input is enabled in the web GUI, configure the alarm on the Dry Contacts and AP LEDs by activating the external alarm within the Dry Contact. Figure 54 below is an example as how to configure the Dry Contact you wish to map the External Alarm. For further details, see the V3 BDA/DAS User Manual.

Navigate to Device → Overview → External/Dry Contact ALM

The screenshot displays the Comba web GUI interface for configuring external alarms. It is divided into three main sections:

- External Alarms Table:** A table listing five external alarms. Each row includes columns for Alarm Name, Remark, Alarm Status (indicated by a green dot), Trigger, RF Control, and Actions (a 'Modify' button).

Alarm Name	Remark	Alarm Status	Trigger	RF Control	Actions
Ext Alarm 1	User Define	●	Normally Open	OFF	Modify
Ext Alarm 2	User Define	●	Normally Open	OFF	Modify
Ext Alarm 3	User Define	●	Normally Open	OFF	Modify
Ext Alarm 4	User Define	●	Normally Open	OFF	Modify
Ext Alarm 5	Door Open Alarm	●	Normally Closed	OFF	Modify
- Dry Contact Alarm Table:** A table listing various dry contact alarm types. Each row includes columns for Dry Contact Alarm Name, Alarm Status (indicated by a green dot), and Actions (Modify and Test buttons).

Dry Contact Alarm Name	Alarm Status	Actions
NORMAL AC POWER	●	Modify Test
LOSS OF NORMAL AC POWER	●	Modify Test
BATTERY CHARGER FAILURE	●	Modify Test
LOW-BATTERY CAPACITY	●	Modify Test
DONOR ANTENNA MALFUNCTION	●	Modify Test
ACTIVE RF-EMITTING DEVICE MALFUNCTION	●	Modify Test
ACTIVE SYSTEM COMPONENT MALFUNCTION	●	Modify Test
- Alarm Configuration Form:** A form for configuring the 'NORMAL AC POWER' alarm. It shows a list of alarm types with checkboxes. The 'AC Normal' checkbox is selected. A red box highlights the 'Ext Alarm 1' through 'Ext Alarm 5' options in the right-hand column.

* Alarm name: NORMAL AC POWER			
<input checked="" type="checkbox"/> AC Normal	<input type="checkbox"/> AC Lost Alarm	<input type="checkbox"/> Charger Fault Alarm	<input type="checkbox"/> Charger Comm. Fault Alarm
<input type="checkbox"/> PA Alarm DL 700MHz	<input type="checkbox"/> LNA Alarm DL 700MHz	<input type="checkbox"/> PA Shutdown Alarm DL 700MHz	<input type="checkbox"/> Ext Alarm 1
<input type="checkbox"/> PA Alarm DL 800MHz	<input type="checkbox"/> LNA Alarm DL 800MHz	<input type="checkbox"/> PA Shutdown Alarm DL 800MHz	<input type="checkbox"/> Ext Alarm 2
<input type="checkbox"/> PA Alarm UL 700&800MHz	<input type="checkbox"/> LNA Alarm UL 700&800MHz	<input type="checkbox"/> PA Shutdown Alarm UL 700&800MHz	<input type="checkbox"/> Ext Alarm 3
<input type="checkbox"/> DL P_in Over Alarm 700MHz	<input type="checkbox"/> DL P_in Low Alarm 700MHz	<input type="checkbox"/> Oscillation Shutdown Alarm	<input type="checkbox"/> Ext Alarm 4
<input type="checkbox"/> DL P_out Over Alarm 700MHz	<input type="checkbox"/> DL P_out Low Alarm 700MHz	<input type="checkbox"/> Oscillation Gain Reduction Alarm	<input type="checkbox"/> Ext Alarm 5
<input type="checkbox"/> DL P_in Over Alarm 800MHz	<input type="checkbox"/> DL P_in Low Alarm 800MHz	<input type="checkbox"/> PLL Alarm	<input type="checkbox"/> Over Temperature Alarm
<input type="checkbox"/> DL P_out Over Alarm 800MHz	<input type="checkbox"/> DL P_out Low Alarm 800MHz	<input type="checkbox"/> Digital Clock Alarm	<input type="checkbox"/> DT ANT Disconnection Alarm
<input type="checkbox"/> VSWR Alarm DL 700MHz	<input type="checkbox"/> VSWR Alarm DL 800MHz	<input type="checkbox"/> Battery Low Alarm	<input type="checkbox"/> Battery Connection Fail Alarm
<input type="checkbox"/> Battery Over Temperature Alarm	<input type="checkbox"/> Battery Comm. Fault Alarm	<input type="checkbox"/> Battery Over-Discharge Alarm	

Figure 54: BDA/MU/RU - External Alarm Settings

4.6 V3 AP SILENCE AND LAMP TEST

The V3 AP models have both a Silence button and a Lamp Test button. The Silence button can be used to mute the buzzer after an alarm is activated. After a user defined period, the alarm buzzer will sound again. Furthermore, if a new alarm becomes active after the Silence button has been pushed, the buzzer will sound to indicate a new alarm is present. The Lamp Test button is used to test all the LEDs on the annunciator front panel. Since most of the time these LEDs remain off, a Lamp Test can check that all LEDs are still working as intended. To Silence an alarm or perform a Lamp Test, you must first activate the Key Switch with the key that is provided in the accessory kit. Refer to Figure 55 below.

To Silence an alarm:

- Insert key into Key Switch and turn 90 degrees clockwise.
- Hold the Silence button for 1s.

To perform a Lamp Test:

- Insert key into Key Switch and turn 90 degrees clockwise.
- Hold the Lamp Test button down for 5s. All the LEDs will illuminate. Release the button and the LEDs will clear.

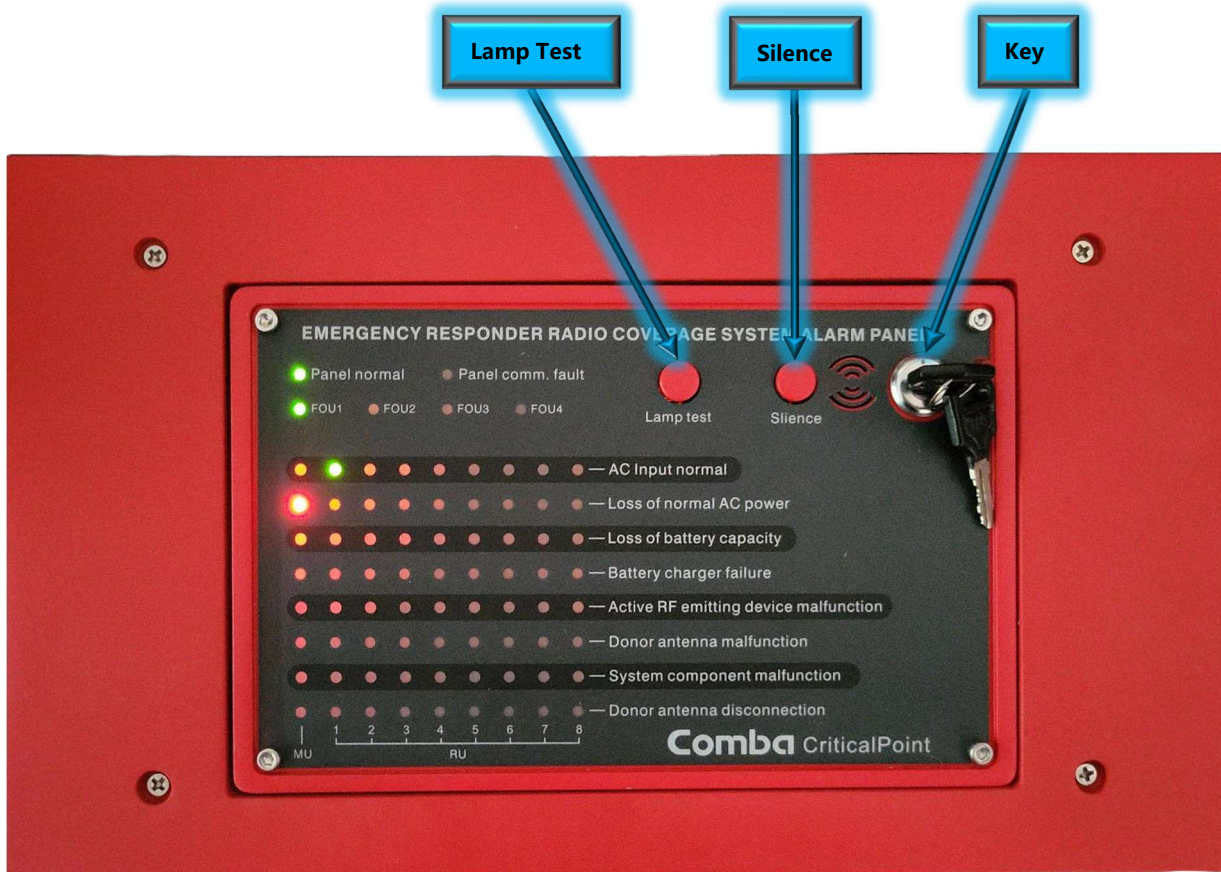

Figure 55: V3 AP - Silence Button, Lamp Test Button, and Key Switch

4.7 V3 AP ALARM SIMULATIONS

See Comba V3 BDA/BBU/DAS User Manual for details on simulating system alarms.

4.8 V3 AP ALARM TROUBLESHOOTING

Refer to the above alarm tables or the Comba V3 BDA/BBU/DAS User Manual for complete overview of troubleshooting system alarms.

4.9 V3 AP MAINTENANCE RECOMMENDATIONS

Refer below for recommended list of items to check when inspecting the V3 AP during a routine maintenance of the system.

- Ensure the device is installed in the same location without any visible damage.
- Check for any visible damage to cabling between the BDA/MU/RU device and the AP.
- Ensure the device is powered and operating by checking the status of the LED indicators.
- Perform a lamp test to ensure all LEDs are still working as intended.
- Simulate a few alarms to ensure proper communication between BDA/MU/RU and AP device.
- Disconnect the RJ45 connection to the BDA/MU/RU device to simulate an AP communication fault. Restore cabling connection and ensure alarm clears.
- Ensure the BDA/MU/RU device has the latest FW installed. The BDA/MU/RU device FW packages have the AP FWs embedded in them and they are deployed to all the connected APs after the BDA/MU/RU device upgrade has completed.

End of Section

5 APPENDICES

5.1 APPENDIX A: TOOLS

The following is the recommended list of tools for new installation and routine maintenance.

- Screwdrivers: Flathead and Phillips
- Pliers
- Level
- Tape Measure
- Power drill and drill bits
- Wire cutters
- Wire Strippers
- Craft Knife
- Anti-static Wrist Strap
- Multimeter
- Personal Protective Gear (Recommended. Follow your local codes and company safety policy for PPE. Additional PPE may be required.)
 - Hard Hat or Bump Cap
 - Protective Gloves
 - Foot Protection
 - Safety Glasses
 - Personal Fall Protection System (Installing at height)
 - Scissor Lift or Scaffolding (Installing at Height)

5.2 APPENDIX B: DECLARATION OF HARMFUL SUBSTANCES AND CONTENT

Product Name: Public Safety Annunciator Panel Version 3

Model: APV3

Harmful substance and content of this product as below table shown:

Part Name	Harmful Substance					
	Pb	Hg	Cd	Cr (VI)	PBB	PBDE
A	×	○	○	○	○	○
B	×	○	○	○	○	○

Note: Above table complies with SJ/T 11364.

○: Indicates that the harmful substance content in all homogeneous materials for corresponding part is under the limited requirement of GB/T 26572.

×: Indicates that the harmful substance content in at least one single, homogeneous material for the corresponding part exceeds the limited requirement of GB/T 26572.

Remark: The content of the parts marked with “×” above exceeds the requirement as there is still no mature alternative technologies to achieve the replacement of poisonous and harmful materials or elements.

Comba

Comba Telecom Inc.

568 Gibraltar Drive, Milpitas, CA 95035

Tel: +1 866 802 7961

Fax: +1 408 526 0181

Email: customer.nam@comba-telecom.com

www.combausea.com

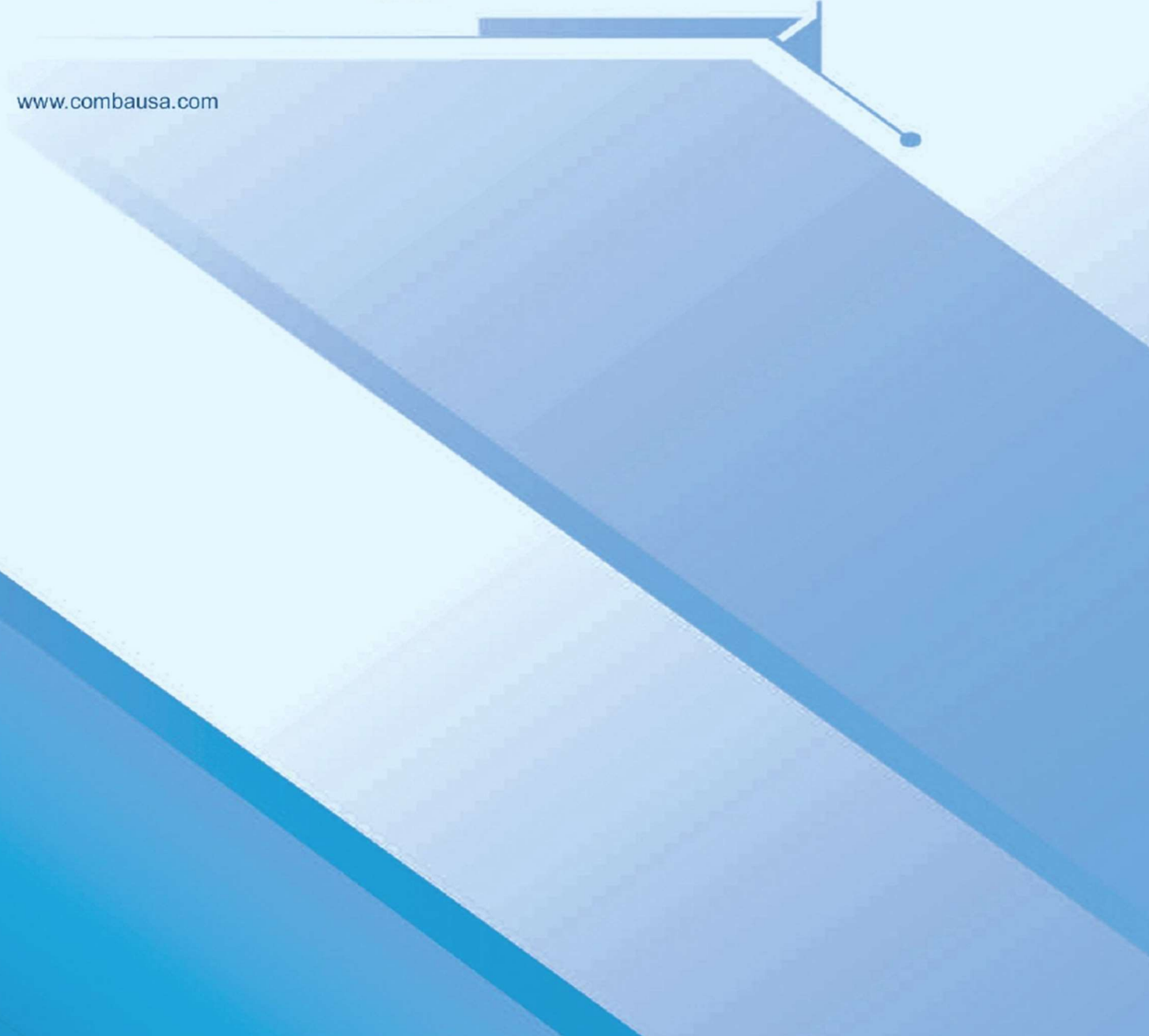
A large, abstract graphic composed of overlapping blue geometric shapes, including a large trapezoid and a smaller triangle, creating a sense of depth and movement. The colors range from light sky blue to a darker, more saturated blue. The graphic is positioned in the lower half of the page, partially overlapping the contact information.