

Connectors for 1/2" Coaxial Cable

CN-NM-F12/CN-NF-F12

CN-4M-F12/CN-4F-F12

N-type, 4.3-10 connectors for CS-F12PAR500, 1/2" Plenum rated Coaxial Cable

Electrical Specifications

Product Model	CN-NM-F12	CN-NF-F12	CN-4M-F12	CN-4F-F12
Connector type	N-Male	N-Female	4.3-10 Male	4.3-10 Female
Frequency (MHz)	DC-6000			
Impedance (ohm)	50.0			
Inner Conductor Contact Resistance (mΩ)	≤1			
Outer Conductor Contact Resistance (mΩ)	≤1			
Insulation Resistance (MΩ)	≥5000			
Insulation Withstanding Voltage (V)	≥1500			
Insert Loss (dB)	≤0.05vf(GHz)			
VSWR	DC-3.0GHz	≤ 1.150		
	3.0-4.2GHz	≤ 1.20		
	4.2-6.0GHz	≤ 1.25		
PIM (dBc)	≤ -161 @ 2x 43dBm (@900MHz, 2x43dBm)			

Mechanical Specifications

Dimension (in/ mm)	2.13x0.87x0.87 / 54.0x22.0x22.0
Weight (lb/kg)	0.18 / 0.08
Shipping Dimension (in/mm)	2.76x1.57x1.57 / 70.0x40.0x40.0
Shipping Weight (lb/kg)	0.26 / 0.12
Interface Durability, number of cycles	100
Connector Type	N-type and 4.3-10type
Outer Conductor Material	Brass, Tri-alloy Plated
Inner Conductor Material	Spring Bronze, Ag Plated
Sealing	Silicone Rubber
Insulator Material	PTFE
Other	Brass, Ni Plated

Environment & Compliance

Application	Indoor / Outdoor
Operation Temperature	-40°C to +85°C
Environment	IP67
Relative Humidity	Up to 95%
RoHS	Compliant
Related Products	CS-F12PAR500 Coax AP-F12, Auto Preparation tool

Outline Drawing

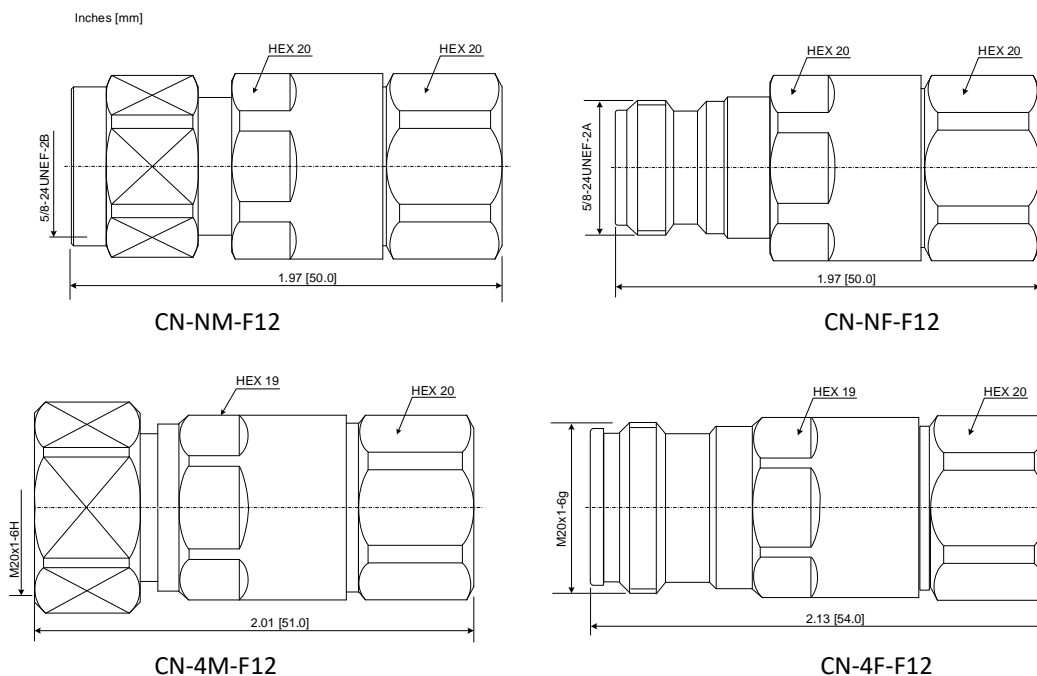

Installation Instruction

CN-NM-F12/CN-NF-F12 and CN-4M-F12/CN-4F-F12 Assembly Procedure

1. Parts

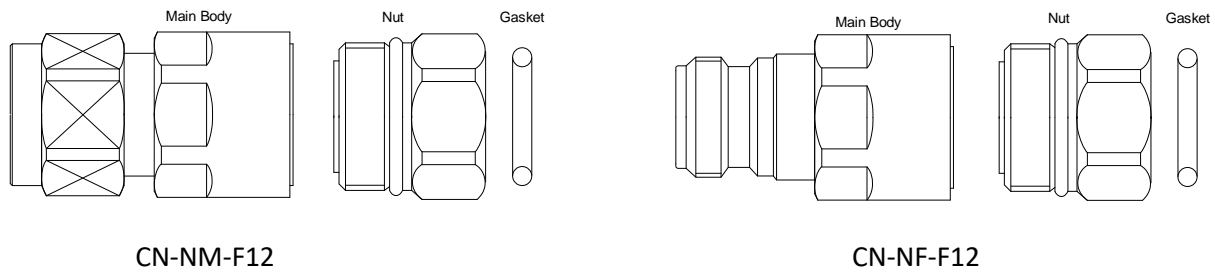

2. Tools

Auto Preparation Tool AP-F12, 2 x HEX 20 wrench

3. Coaxial cable preparation

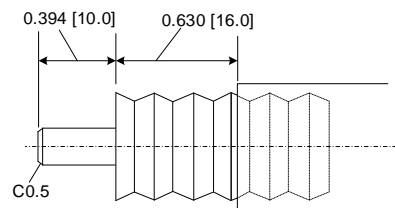
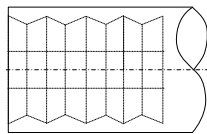

Step 1. Please cut cable as clean as possible. The cutting edge is to be at the top of corrugation

Step 2. Please use auto prep tool, AP-F12 and remove all remaining dielectric material after using auto prep tool

4. Connector Assembly

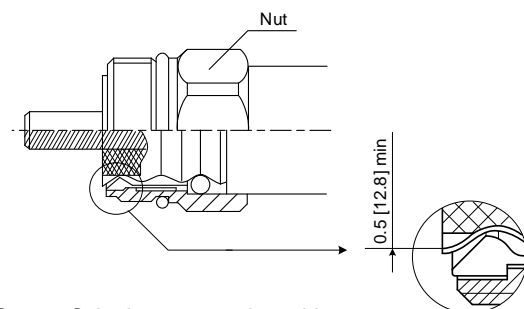
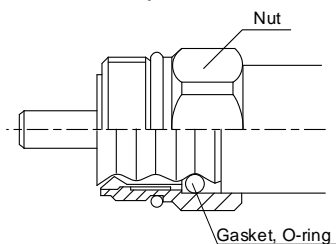

Step 3. Insert the gasket along with the outer conductor and then insert the nut to the coax and align the nut with the coax outer conductor as shown the picture

Step 4. Spin the nut over the cable

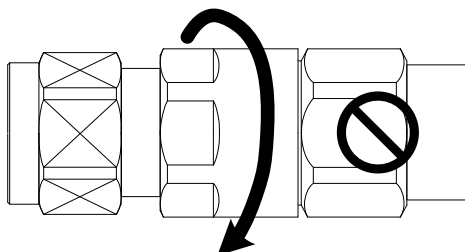

Step 5. Insert the main body to the nut and tighten counterclockwise as shown the picture. Please hold the nut while tightening the main body