

Articulating Antenna Mounting bracket

MT-ND-AR

Articulating Bracket Mount for IWH-080V08NZ/IWH-080V08Z-Q

Installation Instruction

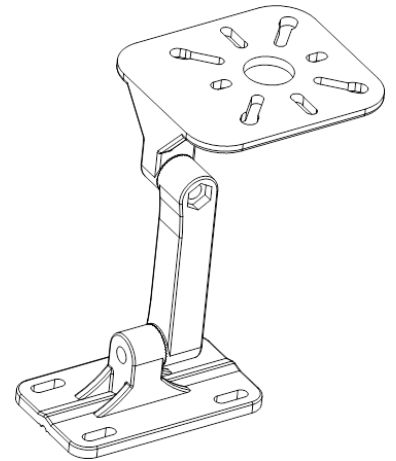

1. Bracket- A is preinstalled on the backside of the antenna.
Please take the bracket-A out from the backside of the antenna.
2. Assembly the bracket-B to same location of the backside of the antenna with 4xM3 screws as shown in the picture
3. Install the articulating mounting kit on the backside of the antenna with 4 sets of M5 nut, the plain washer and the spring washer as shown in the picture
4. Drill holes ($\frac{1}{4}$ " or 6mm diameter) in the wall at least deeper than the length of the expansion bolt
5. Put the expansion bolt into the hole on the wall and then tighten the nuts of The expansion bolt with wrench. The bolt goes outside while the metal sheath does not move
6. Adjust the antenna direction and then tighten the nut after completion of installation

Unit: inches [mm]

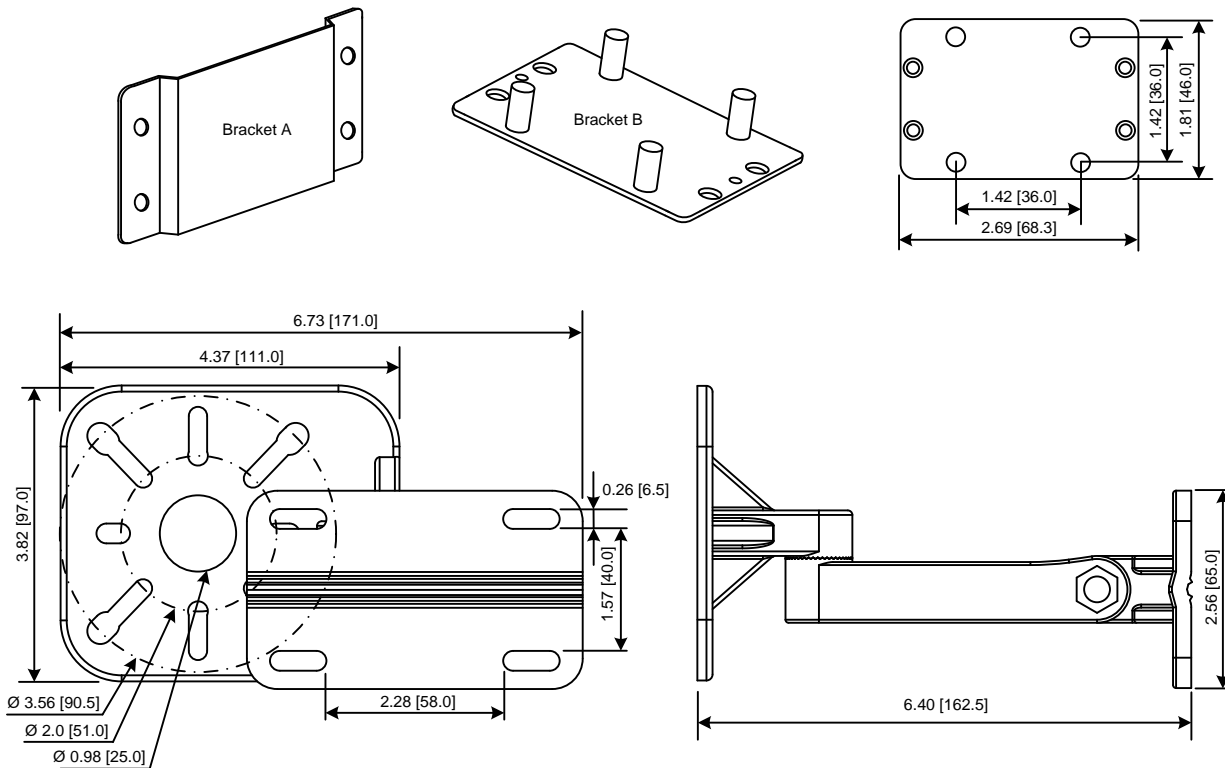

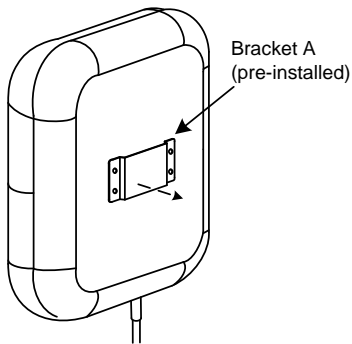

Step 1

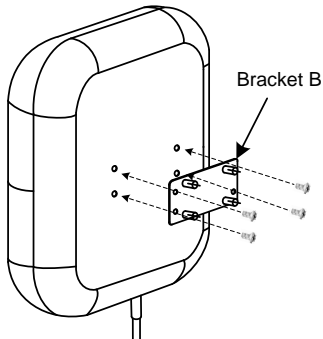

Step 2

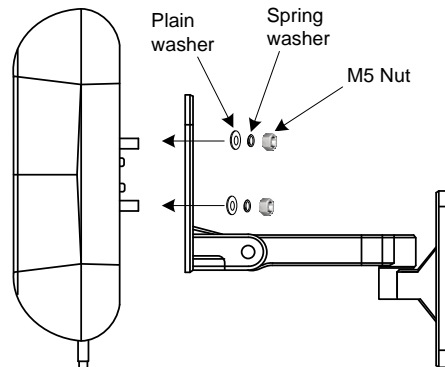

Step 3

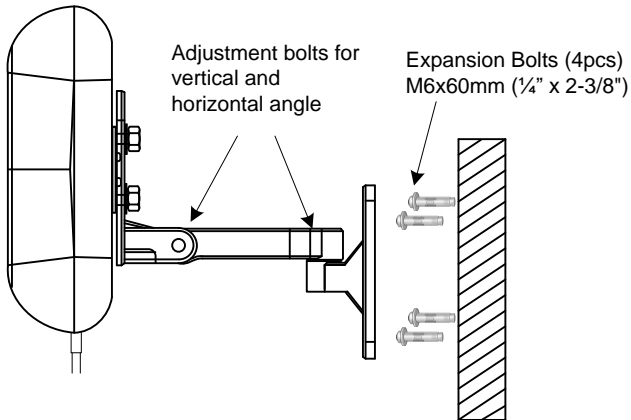

Step 4, 5 and 6

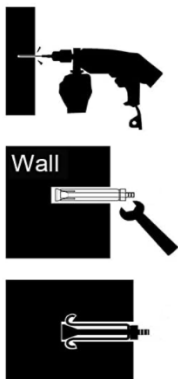

Packing List

Item	Parts	QTY	Material
1	Bracket B	1	Aluminum 3003
2	Mounting Screw M3	4	Stainless steel 304
3	Nut M5	4	Stainless steel 304
4	Spring Washer	4	Stainless steel 304
5	Flat Washer	4	Stainless steel 304
6	Expansion Bolt M6	4	Stainless steel 304

Mechanical Specification

Shipping Dimension(in/mm)	5.51x4.53x4.13 / 140.0x115.0x105.0
Shipping Weight(lb./kg)	1.1 / 0.5