

**Comba**

# **CriticalPoint™ Public Safety**

## **V3 VHF/UHF BDA/DAS/BBU**

### **USER MANUAL**

**RX14V3 / RH14V3 / RHFOUV2 / BBUV3**

**QE: 1-0-2**

**Comba Telecom Limited**

## Table of Contents

Section		Page
0.1	INDEX TO FIGURES AND TABLES .....	5
0.2	REVISION HISTORY .....	10
0.3	ABOUT THIS MANUAL .....	10
0.4	DOCUMENTATION FEEDBACK .....	10
0.5	TECHNICAL SUPPORT .....	11
0.6	RETURN MATERIAL AUTHORIZATION (RMA) .....	11
0.7	WARRANTY .....	11
0.8	UNAUTHORIZED CHANGES TO EQUIPMENT .....	11
0.9	GLOSSARY OF TERMS .....	12
0.10	SAFETY NOTICES AND ADMONISHMENTS .....	14
0.11	FCC AND ISED RULES, COMPLIANCE, AND LABELLING .....	16
0.12	AUTHORIZED EQUIPMENT OPERATORS .....	19
1	GENERAL PRODUCT INFORMATION .....	20
1.1	V3 BDA/BBU SYSTEM STANDARDS COMPLIANCE .....	22
1.2	V3 BDA MAIN FEATURES .....	23
1.3	V3 BDA RF SPECIFICATIONS .....	24
1.4	V3 BDA MECHANICAL SPECIFICATIONS .....	25
1.5	V3 BBU MAIN FEATURES .....	26
1.6	V3 BBU MECHANICAL SPECIFICATIONS .....	26
1.7	V3 BBU LIFEPO <sub>4</sub> BATTERY SPECIFICATIONS .....	26
1.8	V3 MU/RU/BBU FIBER DAS SYSTEM STANDARDS COMPLIANCE .....	27
1.9	V3 MU/FOU/RU FIBER DAS MAIN FEATURES .....	28
1.10	V2 FOU RF AND FIBER SPECIFICATIONS .....	29
1.11	V2 FOU MECHANICAL SPECIFICATIONS .....	29
1.12	V3 MU/RU SYSTEM RF SPECIFICATIONS .....	30
1.13	V3 MU MECHANICAL SPECIFICATIONS .....	31
1.14	V3 RU MECHANICAL SPECIFICATIONS .....	32
1.15	V3 SYSTEM PART NUMBERS EXPLAINED .....	33
1.16	V3 BDA/MU FUNCTIONAL BLOCK DIAGRAM – DUAL BAND DUPLEXED .....	38
1.17	V3 BDA/MU FUNCTIONAL BLOCK DIAGRAM – DUAL BAND SIMPLEXED .....	39
1.18	V3 MU – FOU FUNCTIONAL BLOCK DIAGRAM – DUAL BAND DUPLEXED .....	40
1.19	V2 FOU FUNCTIONAL BLOCK DIAGRAM .....	41
1.20	V3 RU FUNCTIONAL BLOCK DIAGRAM – DUAL BAND DUPLEXED .....	42
1.21	V3 BDA/MU DUAL BAND CABINET DIMENSIONS .....	43
1.22	V3 BDA/MU DUAL BAND CABINET MOUNTING BRACKET DIMENSIONS .....	44
1.23	V3 BDA/MU DUAL BAND CABINET CONNECTIONS .....	45
1.24	V3 BDA/MU DUAL BAND CABINET INTERNAL LAYOUT .....	47
1.25	V3 BDA/MU SINGLE BAND CABINET DIMENSIONS .....	48
1.26	V3 BDA/MU SINGLE BAND CABINET MOUNTING BRACKET DIMENSIONS .....	49
1.27	V3 BDA/MU SINGLE BAND CABINET CONNECTIONS .....	50
1.28	V3 BDA/MU SINGLE BAND CABINET INTERNAL LAYOUT .....	52
1.29	V3 RU CABINET DIMENSIONS .....	53
1.30	V3 RU MOUNTING BRACKET DIMENSIONS .....	54
1.31	V3 RU CABINET CONNECTIONS .....	55
1.32	V3 RU INTERNAL LAYOUT .....	56
1.33	V3 BBU CABINET DIMENSIONS .....	57
1.34	V3 BBU CABINET CONNECTIONS .....	58
1.35	V3 BBU INTERNAL LAYOUT .....	59
1.36	V2 FOU CABINET DIMENSIONS .....	60
1.37	V2 FOU CABINET CONNECTIONS .....	61

1.38	V2 FOU INTERNAL LAYOUT .....	62
1.39	EQUIPMENT CONSTITUTION .....	63
2	INSTALLATION .....	64
2.1	WARNINGS, ALERTS AND CAUTIONS .....	64
2.2	SITE PLANNING CONSIDERATIONS .....	65
2.3	INSTALLATION CHECKLIST .....	66
2.4	GOODS INWARD INSPECTION .....	67
2.5	TOOLS .....	67
2.6	EQUIPMENT GROUNDING .....	67
2.7	V3 BDA/MU/RU MOUNTING BRACKET PREPARATION .....	68
2.8	V3 BDA/MU/RU WALL MOUNTING .....	69
2.9	V3 BDA/MU/RU SYSTEM WIRING - AC POWER ONLY (NO BBU) .....	70
2.10	V3 BDA/MU/RU SYSTEM WIRING - DC POWER ONLY .....	72
2.11	V3 BBU WALL MOUNTING .....	74
2.12	V3 BBU LIFEPO <sub>4</sub> BATTERY INSTALLATION AND WIRING .....	75
2.13	V3 BDA/MU/RU AND BBU SYSTEM WIRING .....	77
2.14	V3 BBU AC INPUT, EPO CONNECTION, AND CONVENIENT AC OUTLETS .....	81
2.15	V3 BDA/MU/RU ADDITIONAL DC OUTPUTS .....	84
2.16	V3 SYSTEM ALARM CONNECTION .....	86
2.17	V3 BDA/MU/RU ANNUNCIATOR FRONT PLATE INSTALLATION .....	88
2.18	V2 FOU WALL MOUNTING .....	90
2.19	V2 FOU 19IN RACK MOUNTING .....	91
2.20	V2 FOU POWER AND COMMUNICATIONS WIRING .....	92
2.21	V3 BDA/MU, V2 FOU, AND V3 RU RF AND FIBER WIRING .....	94
2.22	V3 RU OPTICAL FIBER CABLE GLAND ASSEMBLY .....	95
2.23	SYSTEM RF CONNECTIONS .....	96
2.24	V1 AP ANNUNCIATOR PANEL INSTALLATION AND WIRING .....	97
2.25	V3 AP ANNUNCIATOR PANEL INSTALLATION AND WIRING .....	100
3	COMMISSIONING .....	113
3.1	PRE-COMMISSIONING TASKS .....	113
3.2	REQUIRED RF INPUTS FOR COMMISSIONING .....	114
3.3	COMMISSIONING PROCEDURE - BDA .....	116
3.4	COMMISSIONING PROCEDURE – FIBER DAS OPTION 1 .....	118
3.5	COMMISSIONING PROCEDURE – FIBER DAS OPTION 2 .....	120
3.6	V3 BBU – WAKE UP/TURN ON THE BATTERY .....	122
3.7	V3 BBU – BATTERY SLEEP MODE/TURN OFF THE BATTERY .....	123
3.8	V3 BBU – BATTERY ALARM RESET .....	124
3.9	V3 BDA/MU/FOU/RU POWER ON AND POWER OFF .....	124
3.10	WEB GUI LOGIN AND USER MANAGEMENT .....	126
3.11	WEB GUI OVERVIEW (BDA MODE) .....	128
3.12	WEB GUI OVERVIEW (DAS MODE) .....	129
3.13	CHANGING THE DEVICE OPERATING MODE/TYPE (BDA OR DAS) .....	130
3.14	MODIFYING PARAMETERS VS PARAMETER DIRECT EDIT .....	132
3.15	V3 FIBER DAS – SCANNING, VIEWING AND ACCESSING DEVICES .....	133
3.16	V3 BDA/MU/RU GENERAL SETTINGS .....	138
3.17	V3 BDA/MU NETWORK IP AND SNMP SETTINGS .....	139
3.18	ALARMS (DRY CONTACT / EXTERNAL ALARM / RF CONTROL) .....	140
3.19	BATTERY BACKUP UNIT .....	143
3.20	EXTERNAL ANNUNCIATOR PANEL COMMISSIONING PROCEDURE .....	144
3.21	CREATE A NEW SITE AND ADD CHANNEL FILTERS (CLASS A ONLY) .....	147
3.22	CREATE SUB-BAND FILTERS (CLASS B ONLY) .....	151
3.23	COMMISSIONING TOOLS – DL INPUT TEST (CLASS A BDA ONLY) .....	152
3.24	COMMISSIONING TOOLS – UL INPUT TEST (CLASS A BDA ONLY) .....	154
3.25	COMMISSIONING TOOLS – ISOLATION CHECK .....	157

3.26	COMMISSIONING TOOL PARAMETER CALCULATIONS (CLASS A BDA) .....	162
3.27	POWER, GAIN, ATTENUATION, AND AGC/ALC CONTROLS .....	169
3.28	COMMISSIONING – SETTING POWER, GAIN, AND ATTENUATION .....	173
3.29	COMMISSIONING – PARAMETER OPTIMIZATION .....	178
3.30	COMMISSIONING FIBER DAS – PARAMETER SYNCHRONIZATION.....	183
3.31	ADVANCED SETTINGS – DL VSWR/RETURN LOSS MEASUREMENT.....	185
3.32	ADVANCED SETTINGS – NETPROTECT UL PA MUTING.....	186
3.33	ADVANCED SETTINGS – GAIN LIMIT / LNA BYPASS .....	187
3.34	ADVANCED SETTINGS - OSCILLATION DETECTION AND ALARMS.....	189
3.35	ADVANCED SETTINGS – DONOR ANTENNA ALARMS.....	191
3.36	TOOLS (DEVICE RESET / ALARM LOG / REPORT).....	193
4	FIRMWARE UPGRADES .....	194
4.1	V3 BDA/MU FIRMWARE UPGRADE.....	195
4.2	V2 FOU AND V3 RU FIRMWARE UPGRADE EXPLANATION.....	196
4.3	V2 FOU LOCAL FIRMWARE UPGRADE.....	197
4.4	V3 RU LOCAL FIRMWARE UPGRADE .....	197
4.5	V2 FOU AND V3 RU FIRMWARE UPGRADE FROM BDA/MU .....	198
5	ALARMS, TROUBLESHOOTING, AND MAINTENANCE .....	201
5.1	V3 BDA/MU/RU LED INDICATORS, BUZZER, AND LAMP TEST .....	201
5.2	V2 FOU STATUS LED INDICATORS .....	205
5.3	V1 AP STATUS LED INDICATORS AND BUZZER.....	206
5.4	V3 AP STATUS LED INDICATORS, BUZZER, AND LAMP TEST .....	208
5.5	ALARM INDICATORS IN THE WEB GUI.....	210
5.6	DRY-CONTACT AND EXTERNAL ALARM WIRING .....	213
5.7	DRY-CONTACT AND EXTERNAL ALARM SETTINGS .....	216
5.8	USER DEFINED DRY CONTACT AND LED ALARM CONFIGURATION.....	221
5.9	EXTERNAL ALARMS .....	222
5.10	V3 AP SILENCE AND LAMP TEST .....	223
5.11	DRY-CONTACT ALARM SIMULATIONS.....	224
5.12	V3 BDA/MU/RU ALARM TROUBLESHOOTING .....	226
5.13	V3 BBU AND AP ALARM TROUBLESHOOTING.....	230
5.14	V3 BDA AND FIBER DAS SYSTEM MAINTENANCE .....	232
6	APPENDICES .....	233
6.1	APPENDIX A: TOOLS .....	233
6.2	APPENDIX B: DECLARATION OF HARMFUL SUBSTANCES AND CONTENT.....	234
6.3	APPENDIX C: DEVICE PACKING LIST EXAMPLE .....	235
6.4	APPENDIX D: DEVICE PDF REPORT EXAMPLE .....	236
6.5	APPENDIX E: LIFEPO <sub>4</sub> BATTERY PRO-RATED 5 YEAR WARRANTY .....	239
6.6	APPENDIX F: LIFEPO <sub>4</sub> BATTERY DATASHEETS.....	243
6.7	APPENDIX G: COMBA V3 BDA/MU/RU WIRING DIAGRAMS .....	251
6.8	APPENDIX H: V3 BDA – AUTO DIALER WIRING DIAGRAM.....	258
6.9	APPENDIX I: V3 BBU BATTERY RUNTIME CALCULATIONS EXAMPLE .....	259
6.10	APPENDIX J: V3 BDA/MU/RU AND BBU DOOR STICKER WIRING GUIDE .....	260
6.11	APPENDIX K: V3 FIBER INSTALLATION ADVICE.....	262
6.12	APPENDIX L: TROUBLESHOOTING V3 ANNUNCIATOR PANEL RS485.....	267
6.13	APPENDIX M: TROUBLESHOOTING V3 BBU BATTERY RS485 .....	268
6.14	APPENDIX N: V3 VHF/UHF BDA/MU/RU CHARGER REPLACEMENT .....	269

## 0.1 INDEX TO FIGURES AND TABLES

Figure/Table No.	Page
Figure 1: V3 BDA/BBU with V3 AP High-Level System Diagram .....	21
Figure 2: V3 Fiber DAS High-Level Diagram .....	22
Figure 3: V3 BDA Dual Band Cabinet – Front View .....	23
Figure 4: V3 BDA Single Band Cabinet– Front View .....	23
Figure 5: V3 BBU – Front View .....	26
Figure 6: V3 BBU – Isometric View .....	26
Figure 7: V3 BDA/MU – Front View .....	28
Figure 8: V2 FOU - Front and Isometric View .....	28
Figure 9: V3 RU – Front and Isometric View .....	28
Figure 10: V3 BDA Functional Block Diagram – Duplexed .....	38
Figure 11: V3 BDA Functional Block Diagram - Simplex .....	39
Figure 12: V3 MU to FOU Functional Block Diagram .....	40
Figure 13: V2 FOU Functional Block Diagram .....	41
Figure 14: V3 RU Functional Block Diagram .....	42
Figure 15: V3 BDA/MU Dual Band Cabinet Dimensions – Front, Side, Top and Bottom View .....	43
Figure 16: V3 BDA/MU Dual Band Cabinet Mounting Bracket Dimensions .....	44
Figure 17: V3 BDA/MU Dual Band Cabinet Connections .....	45
Figure 18: V3 BDA/MU Dual Band Internal Component Layout .....	47
Figure 19: V3 BDA/MU Single Band Cabinet Dimensions – Front, Side, Top and Bottom View .....	48
Figure 20: V3 BDA/MU/RU Single Band Cabinet Mounting Bracket Dimensions .....	49
Figure 21: V3 BDA/MU Single Band Cabinet Connections .....	50
Figure 22: V3 BDA/MU Single Band Internal Component Layout .....	52
Figure 23: V3 RU – Cabinet Dimensions .....	53
Figure 24: V3 RU Mounting Bracket Dimensions .....	54
Figure 25: V3 RU Cabinet Connections .....	55
Figure 26: V3 RU Internal Component Layout .....	56
Figure 27: V3 BBU Cabinet Dimensions – Front, Side and Bottom View .....	57
Figure 28: V3 BBU Cabinet Connections .....	58
Figure 29: V3 BBU Internal Component Layout .....	59
Figure 30: V2 FOU Cabinet Dimensions - Front, Side and Bottom View .....	60
Figure 31: V2 FOU Cabinet Connections .....	61
Figure 32: V2 FOU Internal Layout .....	62
Figure 33: V3 BDA/MU/RU Mounting Bracket Overview .....	68
Figure 34: V3 BDA/MU/RU Wall Mounting .....	69
Figure 35: V3 BDA/MU/RU AC Power OFF Switch and Direct AC Power Connection without BBU .....	70
Figure 36: Disabling BBU in the BDA/MU/RU GUI for AC Only Application .....	71
Figure 37: V3 BDA/MU/RU AC Power OFF Switch and Direct 48VDC Power Connection .....	72
Figure 38: V3 BBU Wall Mounting .....	74
Figure 39: Battery Installation and Retaining Bracket .....	75
Figure 40: V3 BBU AC Breaker, Battery Breaker, and Battery Wiring .....	76
Figure 41: V3 BBU to BDA/MU/RU Hybrid Cable .....	77
Figure 42: Hybrid Cable Shielding Wire Installation .....	77
Figure 43: BDA/MU/RU AC and DC Switch OFF .....	78
Figure 44: Hybrid Cable Connection in BBU .....	78
Figure 45: V3 BBU to V3 BDA/MU/RU Hybrid Cable Installation Example .....	79
Figure 46: Liquid Tight Conduit Connector .....	79
Figure 47: Liquid Tight Cable Gland .....	79
Figure 48: V3 BDA/MU/RU Hybrid Cable Wire Connections .....	80
Figure 49: V3 BBU AC Input, AC Breaker OFF, and AC Convenience Outlets .....	81
Figure 50: V3 BBU Main AC Input Installation Example .....	81
Figure 51: V3 BBU EPO Switch Connection .....	82
Figure 52: EPO Switch Wiring Diagram .....	83

Figure 53: V3 BDA/MU/RU Additional DC Outputs ..... 84

Figure 54: Mounting and Wiring DC/DC/Converter to V3 BBU Convenience DIN Rail ..... 85

Figure 55: V3 BDA/MU/RU Dry-Contact Output and External Input Alarms Connection ..... 86

Figure 56: V3 BDA/MU/RU NO Dry-Contact Alarm Wiring Example – UL2524 2<sup>nd</sup> Rev Oct 2018 ..... 87

Figure 57: V3 BDA/MU/RU Annunciator Front Plate Installation ..... 88

Figure 58: V2 FOU Installing and Adjusting Mounting Brackets ..... 90

Figure 59: V2 FOU Wall Mounting ..... 90

Figure 60: V2 FOU 19in Rack Mounting ..... 91

Figure 61: V3 BDA/MU to and V2 FOU Power and Communication Wiring ..... 92

Figure 62: V3 BDA/MU and V2 FOU Power and Communications Wiring – Multiple FOU’s ..... 93

Figure 63: V3 BDA/MU, V2 FOU, and V3 RU RF and Fiber Wiring ..... 94

Figure 64: V3 RU Optical Fiber Cable Gland Assembly ..... 95

Figure 65: V1 AP Annunciator Cabinet Dimensions and Installation ..... 97

Figure 66: V1 AP Internal View and Power Switch ..... 98

Figure 67: V3 BDA/MU and RU – AP V1 Connection ..... 98

Figure 68: V1 AP MCU Address Setting Switch ..... 99

Figure 69: RS485 Address Setting When Using Two V1 APs ..... 99

Figure 70: V3 Annunciator System Diagrams ..... 100

Figure 71: APV3-BDA Dimensions ..... 100

Figure 72: APV3-DAS Dimensions ..... 100

Figure 73: APV3-BDA – Mounting - Gang Box ..... 101

Figure 74: APV3-DAS - Mounting - Gang Box ..... 101

Figure 75: APV3-BDA - Flush Mount Kit Face Plate and Bracket Screw Removal ..... 102

Figure 76: APV3-BDA - Mounting Standard Mounting Bracket to Flush Mount Bracket ..... 103

Figure 77: APV3-BDA - Mounting APV3-BDA into Flush Mount Bracket ..... 103

Figure 78: APV3-BDA - Installing Flush Mount Bracket, APV3-BDA, and Face Plate into a Wall ..... 104

Figure 79: APV3-BDA - Flush Mounting to Wall ..... 105

Figure 80: APV3-DAS - Flush Mount Kit Face Plate and Bracket Screw Removal ..... 106

Figure 81: APV3-DAS - Mounting Standard Mounting Bracket to Flush Mount Bracket ..... 107

Figure 82: APV3-DAS - Mounting APV3-DAS into Flush Mount Bracket ..... 107

Figure 83: APV3-BDA - Installing Flush Mount Bracket, APV3-BDA, and Face Plate into a Wall ..... 108

Figure 84: APV3-DAS - Flush Mounting to Wall ..... 109

Figure 85: V3 BDA/MU/RU - RJ45 Adapter for V3 APs ..... 110

Figure 86: V3 BDA/MU/RU Wiring Connection to V3 AP ..... 111

Figure 87: V3 AP - Address Switch Setting ..... 112

Figure 88: V3 BDA Commissioning Procedure ..... 116

Figure 89: V3 Fiber DAS Commissioning Procedure Option 1 ..... 118

Figure 90: V3 Fiber DAS Commissioning Procedure Option 2 ..... 120

Figure 91: V3 BBU – Waking Up/Turning ON Battery ..... 123

Figure 92: BDA/MU/RU, BBU, and FOU Power Switches and Breakers ..... 125

Figure 93: User Management - Change User Password ..... 127

Figure 94: User Management - Add/Delete Users ..... 127

Figure 95: V3 BDA/MU Web GUI Overview (BDA Mode) ..... 128

Figure 96: V3 BDA/MU Web GUI Overview (DAS Mode) ..... 129

Figure 97: V3 BDA/MU Dashboard Viewing – BDA vs DAS mode ..... 130

Figure 98: V3 BDA/MU Changing Device Operating Mode/Type (BDA or DAS) ..... 131

Figure 99: V3 BDA/MU/RU Modifying Parameters in the WEB GUI ..... 132

Figure 100: V3 Fiber DAS – Scanning to Identify Connected System Devices ..... 133

Figure 101: V3 Fiber DAS – Dashboard Graphic View ..... 134

Figure 102: V3 Fiber DAS – Dashboard Table View ..... 135

Figure 103: V3 Fiber DAS – Accessing FOU’s and RUs from Dashboard Table View ..... 136

Figure 104: V3 Fiber DAS – Accessing FOU’s and RUs from Home screen ..... 137

Figure 105: V3 BDA/MU/RU General Information Settings ..... 138

Figure 106: V3 BDA/MU Network IP and SNMP Settings ..... 139

Figure 107: V3 BDA/MU/RU Dry Contact Alarms, External Alarms, and SW RF Control ..... 140

Figure 108: V3 BDA/MU/RU Dry Contact Alarm Preset Configurations ..... 140

Figure 109: V3 BDA/MU/RU User-Defined/Custom Dry Contact Alarm Configuration ..... 141

Figure 110: V3 BDA/MU/RU External Alarm Configuration ..... 142

Figure 111: V3 BDA/MU/RU Software RF Control using External Alarms ..... 142

Figure 112: V3 BDA/MU/RU Battery Backup Unit Configuration ..... 143

Figure 113: V3 AP Commissioning Procedure ..... 144

Figure 114: Commissioning V3 AP in BDA mode ..... 145

Figure 115: Commissioning V3 AP in DAS Mode ..... 145

Figure 116: External Annunciator Panel WEB GUI Settings ..... 145

Figure 117: V3 BDA/MU Creating a New Site ..... 147

Figure 118: V3 BDA/MU Adding Channel Filters (Class A Only) ..... 148

Figure 119: V3 BDA/MU Deleting Channel Filters (Class A Only) ..... 149

Figure 120: V3 BDA/MU Setting Channel Filter Frequencies (Class A Only) ..... 150

Figure 121: V3 BDA/MU Create Sub-Band Filters (Class B Only) ..... 151

Figure 122: V3 BDA/MU Commissioning Tools – DL Input Test ..... 152

Figure 123: V3 BDA/MU Commissioning Tools – Performing DL Input Test ..... 153

Figure 124: V3 BDA/MU Commissioning Tools – DL Input Test Manual Override ..... 153

Figure 125: V3 BDA/MU Commissioning Tools – UL Input Test ..... 154

Figure 126: V3 BDA/MU Commissioning Tools – Performing UL Input Test ..... 155

Figure 127: V3 BDA/MU Commissioning Tools – UL Input Test Results ..... 155

Figure 128: V3 BDA/MU Commissioning Tools – UL Input Test Manual Override ..... 156

Figure 129: V3 BDA/MU Commissioning Tools – Isolation Check ..... 157

Figure 130: V3 BDA/MU Commissioning Tools – Performing Isolation Check ..... 158

Figure 131: Commissioning Tools – Isolation Check Diagram ..... 158

Figure 132: V3 BDA/MU Commissioning Tools – Isolation Check Results ..... 159

Figure 133: V3 BDA/MU Commissioning Tools – Isolation Check Manual Override ..... 159

Figure 134: Commissioning Tools – Isolation Check - Performing a Manual Isolation Test ..... 160

Figure 135: V3 BDA/MU Commissioning Tools – Isolation Check Automatic Filter SW Turn Off Protection ..... 161

Figure 136: V3 BDA Class A Commissioning Tools and Calculations ..... 162

Figure 137: Using the Commissioning Tool ..... 163

Figure 138: Commissioning Tool Parameter Calculations Diagram ..... 164

Figure 139: Commissioning Tool – UL Total Loss 1 Parameter Explanation ..... 164

Figure 140: Commissioning Tool – Selecting UL Total Loss Parameter ..... 165

Figure 141: Commissioning Tools – UL\_TAR and UL\_GAIN Calculation Example ..... 168

Figure 142: Commissioning Tool – Selecting Sites for DL Channel Power Backoff Calculations ..... 168

Figure 143: Commissioning Tool – Viewing the Suggested RF Parameters ..... 169

Figure 144: Commissioning BDA – Power, Gain, and Attenuation BDA Block Diagram ..... 169

Figure 145: Commissioning BDA – Power, Gain, and AGC/ALC ..... 171

Figure 146: Commissioning Fiber DAS – Power, Gain, and Attenuation BDA Block Diagram ..... 171

Figure 147: Commissioning BDA – Setting Target Channel Power and Gain ..... 173

Figure 148: Commissioning BDA – Setting Input ATT, Output ATT, Gain Limit and Main RF Switches ..... 174

Figure 149: Commissioning Fiber DAS – Batch Setting Power and Gain Settings to RUs ..... 176

Figure 150: Commissioning Fiber DAS – Batch Setting RU Output ATT and UL Gain Limit ..... 177

Figure 151: Optimizing BDA – DL Input ATT and DL Gain Limit ..... 178

Figure 152: Optimizing BDA – UL Input ATT and UL Gain Limit ..... 180

Figure 153: Optimizing Fiber DAS – Batch Setting RF Switches and DL Output ATT ..... 181

Figure 154: Optimizing Fiber DAS – Batch Setting RF Switches, UL Mute, and UL Mute Threshold ..... 182

Figure 155: Optimizing Fiber DAS – Setting MU UL Output ATT ..... 182

Figure 156: Commissioning Fiber DAS – Performing a Sync Check ..... 183

Figure 157: Commissioning Fiber DAS – Batch Settings for MU and RUs ..... 184

Figure 158: Advanced Settings – DL VSWR/Return Loss Measurement Table ..... 185

Figure 159: Advanced Settings – NetProtect UL PA Muting ..... 186

Figure 160: Advanced Settings – Gain Limit / LNA Bypass ..... 187

Figure 161: Setting Gain Limit / LNA Bypass in WEB GUI ..... 188

Figure 162: Advanced Settings – Enabling Oscillation Detection, Shutdown, and Alarms ..... 189

Figure 163: Oscillation Detection Alarm Parameters ..... 190

Figure 164: Advanced Settings – DT Donor Antenna Disconnection and P\_IN LOW Alarm ..... 192

Figure 165: Management – Tools (Device Reset/Alarm Log/Reports).....	193
Figure 166: Comba Firmware Downloads Webpage.....	194
Figure 167: BDA/MU Local Firmware Upgrade Process.....	195
Figure 168: V3 BDA/MU Dashboard Scan for FOUs and RUs.....	196
Figure 169: V2 FOU Local Firmware Upgrade.....	197
Figure 170: V3 RU Local Firmware Upgrade.....	197
Figure 171: V3 BDA/MU Dashboard Scan and FOU Access.....	198
Figure 172: V2 FOU Centralized Download Switch.....	198
Figure 173: Batch Setting RU Centralized Download Switch.....	199
Figure 174: V3 BDA/MU Dashboard Centralized Upgrade Pop-up Window.....	199
Figure 175: V3 BDA/MU Dashboard Firmware Validation.....	200
Figure 176: BDA/MU/RU LED Status Indicators.....	201
Figure 177: V3 BDA/MU/RU Buzzer Notification GUI Control.....	202
Figure 178: V3 BDA/MU/RU Alarm Buzzer Silence and LED Lamp Test Button.....	203
Figure 179: V3 BDA/MU/RU Dry-Contact and LED Lamp Test through the web GUI.....	203
Figure 180: V3 BDA/MU/RU Alarm Detection Duration Setting.....	204
Figure 181: V2 FOU LED Status Indicators.....	205
Figure 182: V1 AP LED Status Indicators.....	206
Figure 183: V1 AP Alarm Matching Setting in V3 BDA/MU/RU WEB GUI.....	207
Figure 184: V3 AP LED Status Indicators.....	208
Figure 185: V3 AP Default LED Alarm Configuration UL2524 2018 2 <sup>nd</sup> Revision.....	209
Figure 186: V3 BDA/MU/RU – Web GUI Alarm Configuration and Status.....	210
Figure 187: Alarms – Relationship between Individual, Dry Contact, and Summary Alarms.....	212
Figure 188: V3 BDA/MU/RU Dry-Contact Output and External Input Alarms Connection.....	213
Figure 189: V3 BDA/MU/RU NO Dry-Contact Alarm Wiring Example – UL2524 2 <sup>nd</sup> Rev Oct 2018.....	214
Figure 190: V3 BDA/MU/RU Normally Open Dry-Contact Wiring Diagram Example.....	215
Figure 191: V3 BDA/MU/RU - Dry Contact and External Alarm Setup through web GUI.....	216
Figure 192: V3 BDA/MU/RU - User Defined Dry Contact Alarm Setup.....	221
Figure 193: V3 BDA/MU/RU - External Alarm Settings.....	222
Figure 194: V3 AP - Silence Button, Lamp Test Button, and Key Switch.....	223
Figure 195: Simulating Battery Charger Failure.....	225
Figure 196: V3 BDA/MU/RU Wiring Reference Door Sticker.....	260
Figure 197: V3 BBU Wiring Reference Door Sticker.....	261
Table 1: V3 BDA/MU Dual Band Cabinet Connections.....	46
Table 2: V3 BDA/MU Single Band Cabinet Connections.....	51
Table 3: V3 RU Cabinet Connections.....	55
Table 4: V3 BBU Cabinet Connections.....	58
Table 5: V2 FOU Cabinet Connections.....	61
Table 6: V3 BBU and EPO Relay Specifications.....	83
Table 7: V3 BDA/MU/RU Annunciator Front Plate Options.....	89
Table 8: System RF Connections Before Power Up.....	96
Table 9: V1 AP Address Switch Setting.....	99
Table 10: V3 AP - Address Switch Setting.....	112
Table 11: Required RF Inputs for Commissioning.....	114
Table 12: V3 BDA Commissioning Tasks Explanation.....	117
Table 13: V3 Fiber DAS Commissioning Procedure Explanation Option 1.....	119
Table 14: V3 Fiber DAS Commissioning Procedure Explanation Option 2.....	121
Table 15: V3 BDA/MU Web GUI Overview (BDA Mode).....	128
Table 16: V3 BDA/MU Web GUI Overview (DAS Mode).....	129
Table 17: External Annunciator Panel WEB GUI Settings Explanation.....	146
Table 18: Commissioning Tool - DL_TAR Channel Power Derating.....	166
Table 19: Commissioning BDA – Power, Gain, Attenuation and AGC/ALC Controls.....	170
Table 20: Commissioning Fiber DAS – Power, Gain, Attenuation and AGC/ALC Controls.....	172
Table 21: Commissioning Fiber DAS – Parameters Synchronized between Master and Remotes.....	183
Table 22: Commissioning Fiber DAS – Parameters NOT Synchronized between Master and Remotes.....	184

Table 23: Oscillation Detection Parameters Explained..... 190

Table 24: Management – Tools Explained (Device Reset/Alarm Log/Reports) ..... 193

Table 25: BDA/MU/RU LED Status General Explanation ..... 201

Table 26: V3 BDA/MU/RU Alarm Buzzer Control ..... 202

Table 27: V2 FOU LED Status Indicator General Explanation ..... 205

Table 28: V1 AP LED Status Indicator General Explanation ..... 206

Table 29: V3 AP LED Status Indicator General Explanation ..... 208

Table 30: V3 AP Default LED Alarm Configuration UL2524 2018 2<sup>nd</sup> Revision ..... 209

Table 31: V3 BDA - Web GUI Alarm Configuration and Status ..... 210

Table 32: V3 Fiber DAS – Web GUI Alarm Configuration and Status ..... 210

Table 33: V3 BDA/MU/RU - Complete List of Device Alarms ..... 211

Table 34: V3 BDA/MU/RU Dry Contact Ratings ..... 213

Table 35: V3 BDA/MU/RU - Dry Contact and LED Alarm Presets ..... 216

Table 36: NFPA 1221 2019 Alarm Preset Dry Contact and LED Operation ..... 217

Table 37: UL2524 Oct 2018 Alarm Preset Dry Contact and LED Operation ..... 218

Table 38: NFPA 1225 2022 Alarm Preset Dry Contact and LED Operation ..... 219

Table 39: IFC 510 2021 Alarm Preset Dry Contact and LED Operation ..... 220

Table 40: Simulating Typical Dry Contact and LED Alarms ..... 224

## 0.2 REVISION HISTORY

Rev. No.	ENU	Release Date	Author	Details Of Change
1	1-0-0	02/14/2025	MD	First Release
2	1-0-1	04/02/2025	MD	Updated Appendix C Packing List
3	1-0-2	03/25/2026	MD	Fiber DAS Sections Released. Various Sections Updated.

## 0.3 ABOUT THIS MANUAL

This user manual describes the pre-planning, installation, commissioning, operation, and maintenance procedures for the Comba CriticalPoint™ V3 VHF/UHF Public Safety series of RF products. A complete overview of the hardware and software is provided. The hardware and software mentioned throughout this manual are under continuous development to provide improvements and/or new features. As a result, there may be minor differences between the information found in this manual and the actual design of the hardware and software received by the operator. Any specifications, weights, dimensions, or other statements mentioned in this manual are subject to change without notice.

**The information contained herein is the responsibility of and is approved by the following, to whom all enquiries should be directed:**

**This is an unpublished work the copyright in which vests in Comba International ("Comba"). All rights reserved. The information contained herein is confidential and the property of Comba and is supplied without liability for errors or omissions. No part may be reproduced, disclosed, or used except as authorized by contract or other written permission by Comba. The copyright and the foregoing restriction on reproduction and use extend to all media in which the information may be embodied.**

## 0.4 DOCUMENTATION FEEDBACK

Comba prides itself in providing our clients with the best customer experience possible. Your feedback can help keep our documentation current and accurate. If you have any comments or suggestions about the content found within this user manual, please feel free to contact us.

Please include the following information when submitting your comments:

- Product Model Number and Version Number
- User Manual Name and Version Number
- Topic Title or Subject
- Page Number
- Brief description of the content you believe should be improved, corrected, or is missing.
- Your recommendation for how to correct or improve the document.

Please send your email messages to the following:

techsupport@combausa.com

Please note this email is for both technical support and documentation feedback.

## 0.5 TECHNICAL SUPPORT

Comba provides direct access to our technical support team 11 hours a day (Mon-Fri) from 9:00am (EST) to 5:00pm (PST). Technical support is provided for free for the entire time the product is covered by the equipment warranty, on condition that the user/operator has a valid certificate of training completion issued by Comba for the product in question. Unauthorized individuals should not be servicing the equipment and will not be assisted over the phone due to liability issues. See Section 0.12 for details on who is authorized to operate the equipment.

For technical support please contact us at the telephone number or email address below or submit a ticket for support through the website.

Tel: (408) 526 0180 Ext. 3  
techsupport@combausa.com  
<https://combausa.com/technical-support-request-form/>

## 0.6 RETURN MATERIAL AUTHORIZATION (RMA)

If you need to request an RMA, please call the technical support line mentioned in Section 0.5 or complete the RMA form on our website and a Comba representative will contact you shortly.

<https://combausa.com/rma-request-form/>

## 0.7 WARRANTY

The standard product warranty is 3 years or as otherwise agreed under a special contract with Comba.

Comba Telecom provides a warranty for the Lithium Iron Phosphate (LiFePO<sub>4</sub>) batteries that are utilized in the Comba Version 2 and Version 3 Battery Backup Units for up to 5 years (60 months) pending certain terms and conditions.

The warranty period commences upon the date of shipment from Comba Telecom.

**Please see Appendix E for the full Comba Telecom LiFePO<sub>4</sub> Battery Pro-rated 5 Year Warranty statement.**

## 0.8 UNAUTHORIZED CHANGES TO EQUIPMENT

Any changes or modifications to the equipment not expressly approved by Comba Telecom (who are responsible for compliance) could void the user's authority to operate the equipment. Furthermore, unauthorized changes or modifications could void the device warranty. If you have any questions regarding what modifications can be made to specific equipment, please contact the technical support line mentioned in Section 0.5.

## 0.9 GLOSSARY OF TERMS

Abbreviation	Definition
AGC	Automatic Gain Control
AHJ	Authority Having Jurisdiction
ALC	Automatic Level Control
AP	Annunciator Panel
ATT	Attenuator
BATT	Battery
BBU	Battery Backup Unit
BDA	Bi-Directional Amplifier
BTS	Base Transceiver Station
CH	Channel
CSA	Cross Sectional Area
dB	Decibel
dBm	Decibels relative to one milliwatt
DL	Downlink
DT	Donor Terminal (Base/Donor Port)
DPX	Duplexer
ERCES	Emergency Responder Communication Enhancement System
ERRCS	Emergency Responder Radio Communication System
FCC	Federal Communications Commission
FOU	Fiber Optic Unit
FPGA	Field-Programmable Gate Array (Digital Signal Processor)
FS	Frequency Selection
GND	Ground
GUI	Graphical User Interface
Hz	Hertz
IC	Industry Canada
ID	Identification
IF	Intermediate Frequency
ISED	Innovation, Science and Economic Development Canada
LNA	Low Noise Amplifier
LOS	Line-of-Sight
MCU	Main Control Unit
MHz	Megahertz
MPX	Multiplexer
MT	Mobile Terminal (Service/Mobile Port)
MTBF	Mean Time Between Failures
MU	Master Unit
NF	Noise Figure
OMC	Operation & Maintenance Center
OMT	Operation & Maintenance Terminal

OP	Optical Port
PA	Power Amplifier
PE	Protective Earth
PLL	Phase Locked Loop
PS	Public Safety
PSU	Power Supply Unit
RF	Radio Frequency
RFU	Radio Frequency Unit
RMA	Return Material Authorization
RU	Remote Unit
RX	Receive
SMA	Sub-Miniature A Connector
TX	Transmit
UHF	Ultra-High Frequency
UL	Uplink
VAC	Volts Alternating Current
VDC	Volts Direct Current
VHF	Very-High Frequency
VSWR	Voltage Standing Wave Ratio
W	Watts

## 0.10 SAFETY NOTICES AND ADMONISHMENTS

This document contains safety notices in accordance with appropriate standards. In the interests of conformity with the territory standards for the country concerned, the equivalent territorial admonishments are also shown.

**Installation, adjustment, maintenance, and/or repair of the equipment must only be conducted by trained/certified personnel! At all times, personnel must comply with any safety notices and instructions! Before installing, modifying, or replacing any of the equipment, the user manual should be read and understood in its entirety.**

Specific hazards are indicated by symbol labels on or near the affected parts of the equipment. The labels conform to international standards, are triangular, and are colored black on a yellow background. An informative text label may accompany the symbol label.



General Warning



High Voltage



Non-ionizing Radiation Hazard



Electric Hazard



Laser Hazard

Hazard labeling is supplemented by safety notices in the applicable sections of this manual. These notices contain additional information on the nature of the hazard and may also specify precautions.

Example:



Non-ionizing Radiation Hazard

**For compliance with the general population RF exposure limits, each individual antenna used for this transmitter must be installed to provide a separation distance during normal operation and must not be co-located with any other antenna for meeting RF exposure requirements.**

### Warning Notices:

These draw the attention of personnel to hazards that may cause death or injury to the operator or others. Examples of use are cases of high voltage, laser emission, toxic substances, point of hot temperature, etc.

Example:



Electric Hazard

**WARNING. Electric Shock may occur if the signal booster is installed near water.**

### Alerts:

These draw the attention of personnel to hazards that may cause damage to the equipment.

Examples:



General Warning

**ALERT! Disconnection of either of the RF ports (unloaded) may cause damage to the equipment when power and equipment is active.**

**Caution Notices:**

These may also be used in the handbook to draw attention to matters that do not constitute a risk of causing damage to the equipment, but where there is a possibility of seriously impairing its performance, e.g., by mishandling or gross maladjustment. Warnings and Cautions within the main text may not incorporate labels and may be in shortened form.

Example:



**WARNING.** This is **NOT** a **CONSUMER** device. It is designed for installation by **FCC LICENSEES** and **QUALIFIED INSTALLERS**. You **MUST** have an **FCC LICENSE** or express consent of an **FCC Licensee** to operate this device. The **PS BDA** can be configured as **Class A** or **Class B Signal Booster**. You **MUST** register **Class B** signal boosters (as defined in **47 CFR 90.219**) online at [www.fcc.gov/signal-boosters/registration](http://www.fcc.gov/signal-boosters/registration). **Unauthorized use may result in significant forfeiture penalties, including penalties of more than \$100,000 for each continuing violation.**

**Note:** The grantee is not responsible for any changes or modifications not expressly approved by the party responsible for compliance. Such modifications could revoke the user's authority to operate the equipment.



**CAUTION!** Use only authorized and approved antennas, cables and/or coupling devices! The use of unapproved antennas, cables or coupling devices could cause damage and may be a violation of FCC regulations. The use of unapproved antennas, cables and/or coupling devices is illegal under FCC regulations and may subject the user to a fine.



**CAUTION!** Ambient temperature range for equipment use: **-33 to 55 degrees Celsius.**



**CAUTION!** This equipment is not suitable for use in locations where children are likely to be present.



**CAUTION!** The product shall have a connection of the equipment protective earthing conductor to the installation protective earthing conductor (for example, by means of a power cord connected to a socket-outlet with earthing connection).



**CAUTION!** When the plug on the power supply cord is used as the disconnect device, the socket-outlet shall be easily accessible.

## 0.11 FCC AND ISED RULES, COMPLIANCE, AND LABELLING

Comba Telecom's CriticalPoint™ Public Safety RF products have been designed, evaluated, and certified to meet or exceed the rules defined for FCC CFR47 Part 90 Signal Boosters and ISED RSS-131 Issue 4 Zone Enhancers. Signal Boosters/Zone Enhancers are a type of Industrial device and should only be installed and operated by authorized individuals. A Signal Booster/Zone Enhancer should never be installed or operated without receiving express consent from the FCC/ISED Licensee. In addition, Signal Boosters, defined as FCC Class B, must be registered directly with the FCC before being used. Please ensure you register the Signal Booster with the FCC if it is intended to operate in a Class B mode. **If you have changed/upgraded a Class A device to use Class B filtering using a software license upgrade, you must contact Comba Technical Support to arrange for new labels to ship out to be adhered to the device.**

### FCC Signal Booster Definitions and Labelling

**Class A Signal Booster:** A signal booster designed to retransmit signals on one or more specific channels. A signal booster is deemed to be a Class A signal booster if none of its passbands exceed 75 kHz.

The following is an example of the label which is placed on the Class A devices:

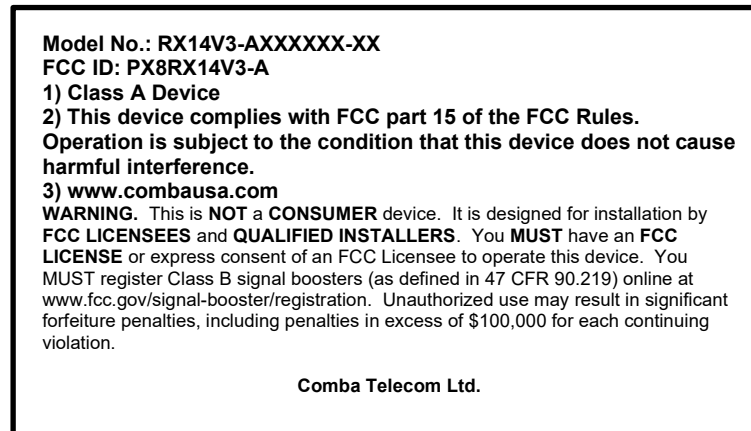

**Class B Signal Booster:** A signal booster designed to retransmit any signals within a wide frequency band. A signal booster is deemed to be a Class B signal booster if it has a passband that exceeds 75 kHz.

The following is an example of the label which is placed on the Class B devices:

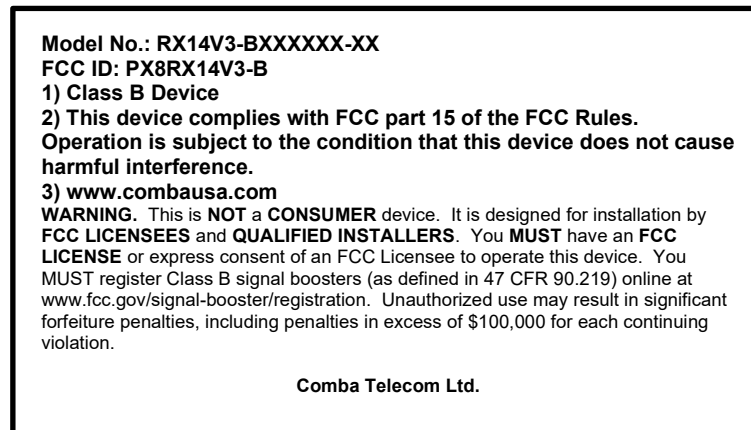

### Web Address to Register Class B Signal Boosters:

<https://signalboosters.fcc.gov/signal-boosters/>

## ISED Zone Enhancer Definitions and Labelling

Class A Zone Enhancer: A zone enhancer designed to retransmit signals on one or more specific channels. A zone enhancer is deemed to be a Class A zone enhancer if none of its passband's bandwidth (20 dB bandwidth) for one or more specific channels exceed 75 kHz.

The following is an example of the label which is placed on the Class A devices:

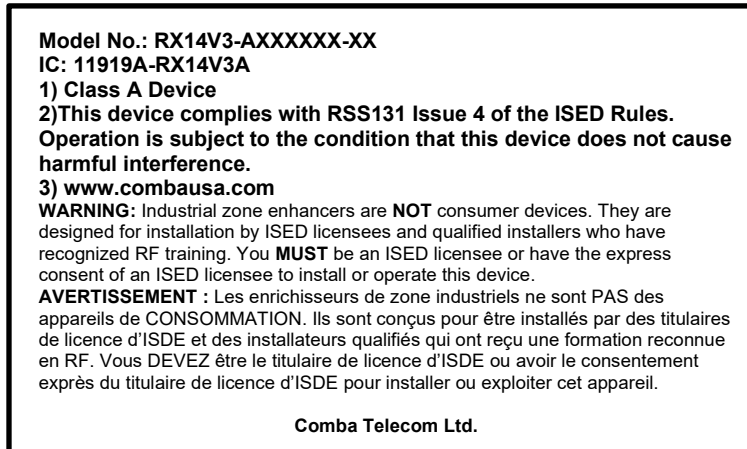

Class B Signal Booster: A zone enhancer designed to retransmit any signals within a wide frequency band. A zone enhancer is deemed to be a Class B zone enhancer if it has a passband bandwidth (20 dB bandwidth) that exceeds 75 kHz.

The following is an example of the label which is placed on the Class B devices:

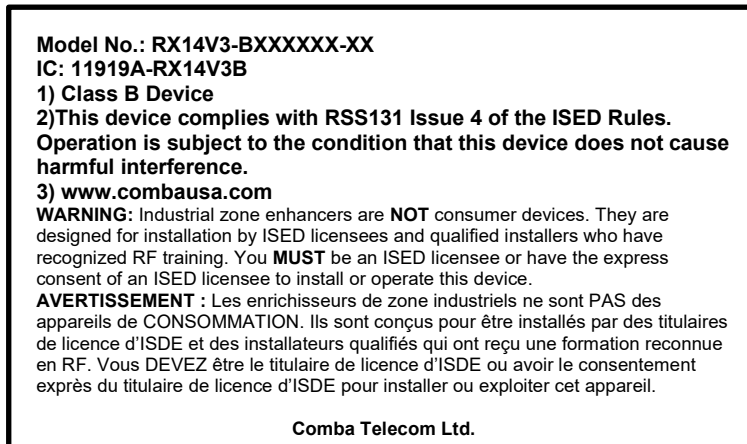

### Web Addresses for ISED requirements and Licensing rules:

<https://ised-isde.canada.ca/site/spectrum-management-telecommunications/en/learn-more/key-documents/procedures/client-procedures-circulars-cpc/cpc-2-1-05-zone-enhancers>

<https://ised-isde.canada.ca/site/spectrum-management-telecommunications/en/rss-131-zone-enhancers>

<https://ised-isde.canada.ca/site/spectrum-management-telecommunications/en/devices-and-equipment/radio-equipment-standards/radio-standards-specifications-rss/rss-gen-general-requirements-compliance-radio-apparatus>

<https://ised-isde.canada.ca/site/spectrum-management-telecommunications/en/devices-and-equipment/broadcasting-equipment-standards/broadcasting-equipment-technical-standards-bets/devices-and-equipment/broadcasting-equipment-standards/broadcasting-certificate-exempt-radio-apparatus-0>

## FCC and ISED Signal Booster/Zone Enhancer Emissions Rules and Exposure Limits

Comba Telecom has designed mechanisms within the Signal Booster/Zone Enhancer hardware and software that can be used to optimize RF performance and minimize the impact to the outdoor network. **HOWEVER**, it is important to note that poor system design or poor adjustment to the device settings can lead to violations of the deployment rules defined by FCC and ISED, and even worse, could generate harmful interference to the outdoor network potentially impairing widespread radio communications. Good engineering practice **MUST** be used when operating the device to ensure you do not violate any of these rules or generate harmful interference. Comba Telecom is not responsible for meeting these emissions rules. The signal booster/zone enhancer operator is responsible for meeting these emissions rules.

### Web Address for FCC Part 90 Section 90.219 rules:

<https://www.ecfr.gov/current/title-47/chapter-I/subchapter-D/part-90/subpart-I/section-90.219>

### Web Addresses for ISED rules:

<https://ised-isde.canada.ca/site/spectrum-management-telecommunications/en/learn-more/key-documents/procedures/client-procedures-circulars-cpc/cpc-2-1-05-zone-enhancers>

<https://ised-isde.canada.ca/site/spectrum-management-telecommunications/en/rss-131-zone-enhancers>

<https://ised-isde.canada.ca/site/spectrum-management-telecommunications/en/devices-and-equipment/radio-equipment-standards/radio-standards-specifications-rss/rss-gen-general-requirements-compliance-radio-apparatus>

<https://ised-isde.canada.ca/site/spectrum-management-telecommunications/en/devices-and-equipment/broadcasting-equipment-standards/broadcasting-equipment-technical-standards-bets/devices-and-equipment/broadcasting-equipment-standards/broadcasting-certificate-exempt-radio-apparatus-0>

This device complies with Part 15 of the FCC rules and RSS-131 Issue 4 of the ISED rules. Comba cannot accept responsibility for any failure to satisfy the protection requirements resulting from a non-recommended modification or adjustment of the product. Operation is subject to the following conditions:

1. This device may not cause harmful interference and
2. This device must accept any interference received, including interference that may cause undesired operation.
3. Nominal Passband Gain: 85dB MAX
4. Rated Mean Output power: up to +33dBm MAX per band.
5. Input and output Impedances: 50 ohms.

The manufacturers rated output power of this equipment is for single carrier operation. For situations where multiple carrier signals are present, the rating must be reduced by  $10 \times \text{Log}(\# \text{ of carriers})$ , especially where the output signal is re-radiated and can cause interference to adjacent band users. This power reduction is done by the input power or gain reduction and not done by an attenuator at the output of the device.

The equipment complies with FCC/IC radiation exposure limits set forth for an uncontrolled environment and meets the FCC radio frequency (RF) Exposure Guidelines in Supplement C to OET65 and RSS-102 of the IC radio frequency (RF) Exposure rules. This equipment should be installed and operated so that the antenna gains and passive losses between the signal boosters used with this device should result in 0dBi or less radiated power and the antenna/radiator is at least 7.9 inches (20cm) or more away from a person's body.

RF Exposure Statement for ISED: "This device complies with Health Canada's Safety Code. The installer of this radio equipment must ensure that the antenna is located or pointed such that it does not emit RF field more than Health Canada limits for the general population; consult Safety Code 6, obtainable from Health Canada's website <https://www.hc-sc.ca/rpb>.

The antenna(s) used for this transmitter must be installed to provide a separation of at least 18" (45 cm) in DL and 18" (45 cm) in UL from all persons and must not be collocated or operating in conjunction with any other antenna or transmitter. Changes or modifications not expressly approved by the party responsible could void the installer's authority to operate the equipment.

## 0.12 AUTHORIZED EQUIPMENT OPERATORS

Signal Boosters/Zone Enhancers (Also referred to BDAs or Fiber Fed BDAs) are not consumer devices. They are industrial devices which may only be operated and maintained by authorized individuals and qualified installers.

1. Operators of the equipment MUST have taken and passed Comba Telecom's certification training for RF101 and the V3 BDA/DAS/BBU product line.
2. Operators of the equipment MUST have a valid FCC General Radio Operator License (GROL) if operating the device in the USA.
3. Operators of the equipment MUST have NICET Level 3 Certification IB-PSC; or they MUST have NICET Level 2 Certification IB-PSC and be supervised by someone who has NICET Level 3 IB-PSC if operating the device in the USA.
4. Installers of the equipment MUST have NICET Level 2 Certification IB-PSC or higher; or they MUST have NICET Level 1 Certification IB-PSC and be supervised by someone with NICET Level 2 Certification IB-PSC or higher while operating the device in the USA.
5. Non-Licensee Operators MUST receive express written consent to operate the Signal Booster/Zone Enhancer from the FCC/ISED License Holder BEFORE installing and operating the device.

The equipment must be installed and operated in accordance with any license required by the radio authorities in the country of concern. In most cases, it is a criminal offense if one fails to obtain a license to install and operate the equipment. It is the operator's responsibility to ensure that any required licenses are obtained, that systems are installed and commissioned in accordance with their terms, and that no changes can be made later that would disobey them.

Comba reserves the right to seize sales to a client and/or report the violation to the proper authorities should we determine if a client is allowing unauthorized individuals to operate the equipment. Comba will not be held responsible for unauthorized use of our devices.

End of Section

## 1 GENERAL PRODUCT INFORMATION

The CriticalPoint™ V3 platform of VHF/UHF BDA and Fiber DAS products consists of a Bi-Directional Amplifier/Master Unit (BDA/MU), a Fiber Optic Expansion Unit (FOU), a Remote Unit (RU), a Battery Backup Unit (BBU), and an external Annunciator Panel (AP). The platform of products was designed as a system to provide a scalable solution for small or large VHF/UHF ERRCS/ERCES projects. The BDA/MU has a dual personality, which means it can be used in a stand-alone application where only a single BDA is required to provide adequate coverage, or in a Fiber DAS application where multiple FOU and RU devices are fed from the main BDA/MU to provide coverage to multiple zones. Furthermore, the BDA/MU is field-changeable from BDA mode to MU mode by simply selecting the correct setting in the GUI depending on if you are using as a stand-alone BDA or in a Fiber DAS configuration. This provides flexibility to install as a stand-alone BDA system first and expand to a Fiber DAS system later.

The BDA/MU/RU devices are FPGA-based which utilize sophisticated signal processing to provide the digital features necessary for optimum system performance. The BDA devices are dual band, supporting the VHF and UHF public safety bands for the US and Canada. There are several different models available depending on the required PS Frequency Band(s). Each band utilizes separate FPGA based intermediate filtering (digital filtering). The devices support both Class A and Class B digital filtering which is field-changeable through the SW GUI. The VHF Class A devices support up to 24 DL channel filters and 24 UL channel filters and the UHF Class A devices support up to 32 DL channel filters and 32 UL channel filters. There are several digital filter options the user can choose from to allow for the best balance of rejection vs. group delay performance. The user can choose between high rejection (higher selectivity and delay) digital filters or Low Delay (lower selectivity and delay) digital filters. The Class B devices support up to 3 sub band filters per band which can be programmed with a minimum BW of 200KHz and a maximum BW of 5MHz. The BDA/MU and RU devices have models that support a VHF DL Composite Power of 24dBm and UHF DL Composite Power of 30dBm. The BDA/MU and RU devices have models that support a VHF UL Composite Power of 24dBm and UHF UL Composite Power of 27dBm.

Each BDA/MU or RU device has an integrated battery charger inside which can be used in conjunction with a Comba V3 BBU. The V3 BDA/MU/RU connects to the V3 BBU to allow the system to have a secondary source of power should there be a loss of normal 120VAC power. There are 3 different battery capacity options available (30Ah, 60Ah, and 100Ah) depending on the backup runtime requirement. The battery options available are designed to support the standard requirements for either a 12-hour or 24-hour backup runtime. You must select the correct battery option depending on your specific requirements. The V3 BBU also has a simple connection point where an Emergency Power Off (EPO) switch can be easily integrated. An EPO switch can be used to disconnect AC and DC (Battery) power from the circuit by a simple push of a button.

System alarms are displayed on the built-in annunciator panel of both the BDA/MU and the RU devices. The BDA/MU and RU devices are provided with several different default annunciator panel front plates that can be used depending on the code that is being enforced in the jurisdiction. The user can select the correct code revision that is being used in the user GUI and attach the correct annunciator front plate to easily comply with the alarm requirements of any jurisdiction. Furthermore, a custom blank annunciator front plate is provided that can be used for custom alarm applications. The installer can add their own labels to the front plate according to the required custom alarm configuration. When a configured system alarm is active, the corresponding LED on the front panel annunciator will illuminate and an onboard buzzer will begin to sound. A mute/silence button is located inside the BDA/MU and RU devices if the user wishes to silence an active alarm. Additionally, alarms can connect from the BDA/MU or RU to a Comba V1 or V3 external Annunciator Panel (AP) with a dedicated cable. The external/remote AP can be installed at a different location than the BDA/MU or RU and provides visual and audible annunciation of configured alarms. Furthermore, the V1 AP has its own set of dry-contact alarm outputs which can feed directly to the fire alarm panel. Alternatively, the BDA/MU and RU devices contain their own dedicated dry-contact alarm outputs which can be fed directly to the fire alarm panel.

When using the platform of products in a Fiber DAS configuration, The BDA/MU will interface with the FOU(s) to expand to feed a system of up to 32 RU's. The FOU connects to the BDA/MU using 2 SMA style coax jumpers (one for DL and one for UL), a DC Power Cable, and an ethernet RJ45 cable for RS485 communications. Each FOU can support either 4 or 8 RU's. Each BDA/MU can support feeding up to 4 FOU's.

This means a fully loaded system using 1 BDA/MU and 4 FOUs can feed up to 32 RUs from a single donor antenna. The FOU's main function is to convert the RF signals to Optical signals and vice versa in the reverse path such that they can be transmitted over a long distance and recovered. The FOU interfaces to each RU using a single strand of single-mode fiber using wave-division multiplexing (WDM) technology. The maximum fiber loss that can be tolerated between the FOU and RU is 6.5dB and the reflectance must be -60dB or lower. Fiber losses exceeding 6.5dB and/or having a reflectance higher than -60dB can cause communication and RF performance degradation and/or complete failure of the fiber link.

The RU is a fiber-fed type of BDA which receives the optical signals in the DL, converts them back to RF and provides final DL amplification and transmission onto the service antenna network. In the uplink path it receives UL signals, conditions them, and then converts them to Optical signals to be transmitted to the FOU. Each RU provides coverage to a different zone of a project and connects to its own indoor antenna network.

Figures 1 and 2 below show the system diagrams for a BDA/BBU system and a Fiber DAS system respectively.

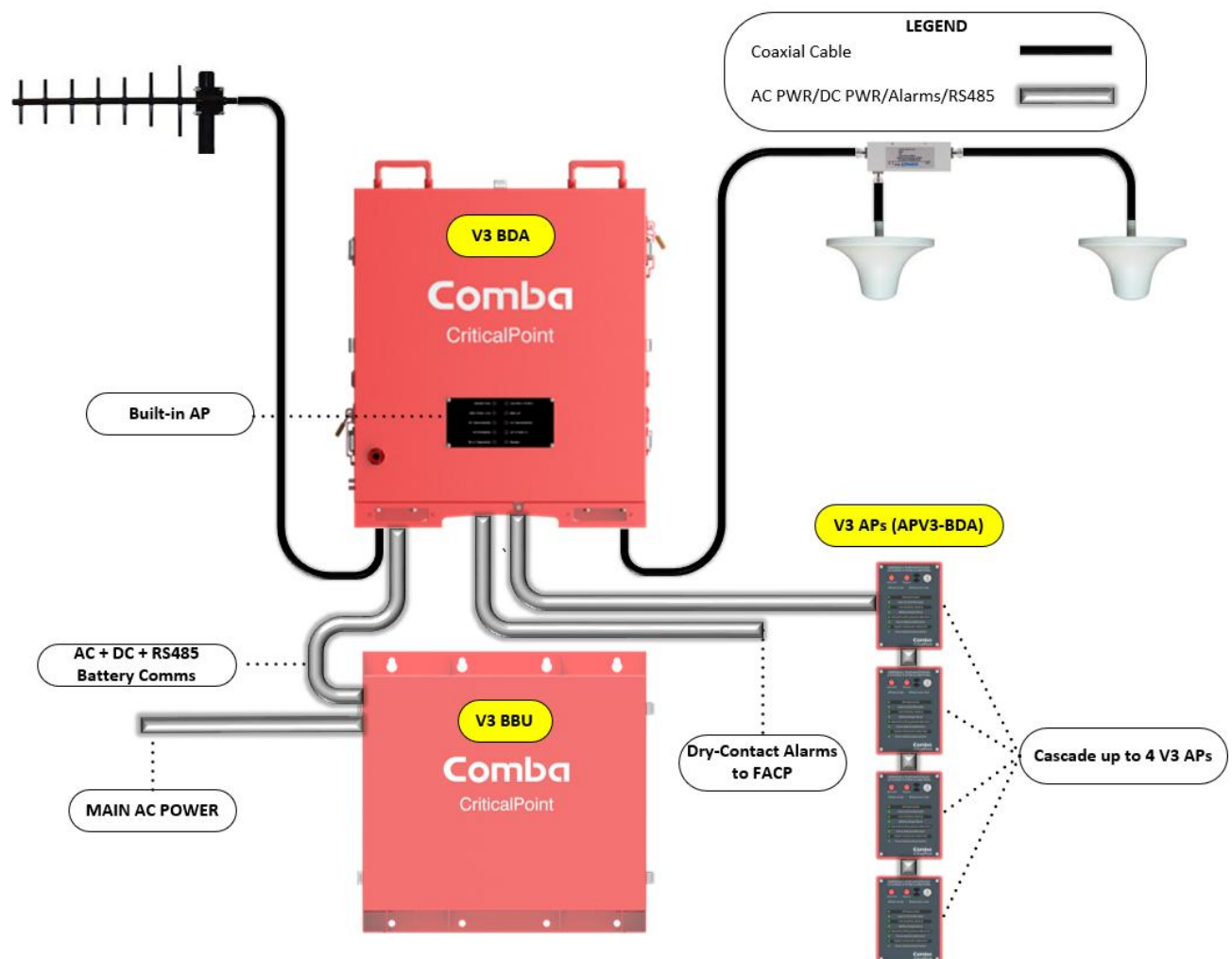

Figure 1: V3 BDA/BBU with V3 AP High-Level System Diagram

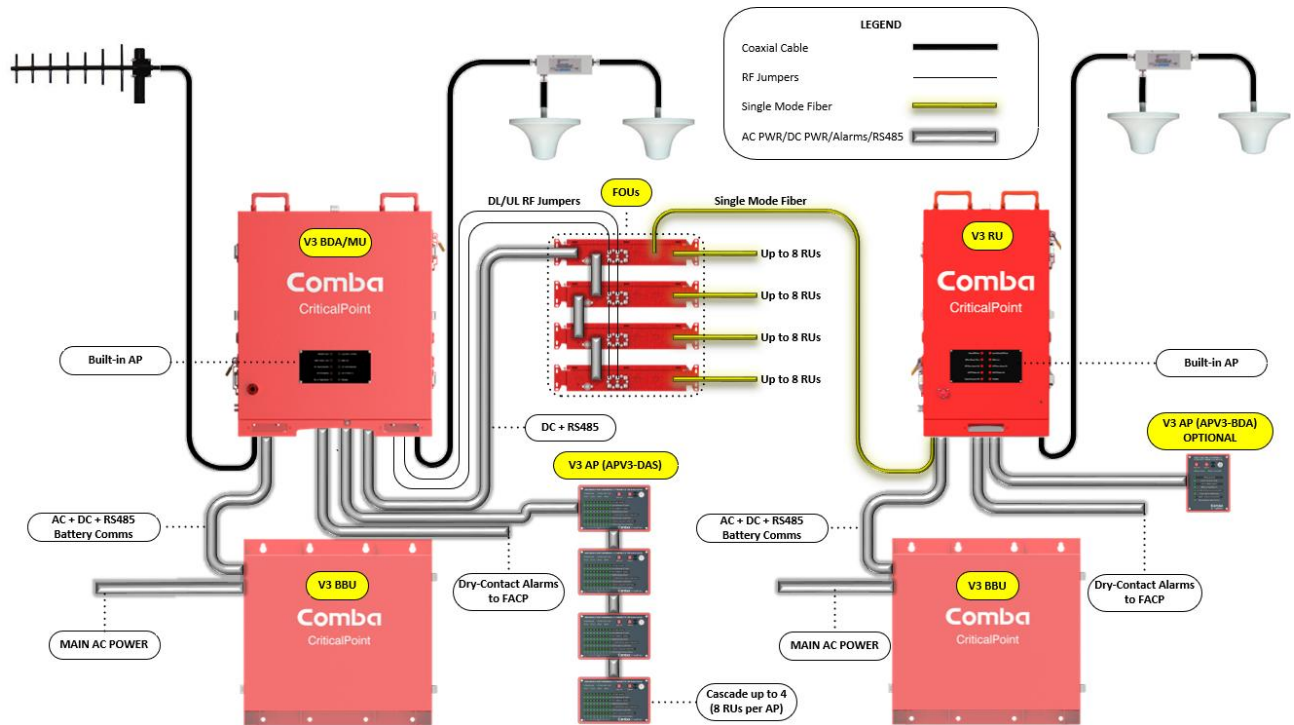

Figure 2: V3 Fiber DAS High-Level Diagram

## 1.1 V3 BDA/BBU SYSTEM STANDARDS COMPLIANCE

- Complies with IFC / NFPA / UL2524 3<sup>rd</sup> Revision
- BDA Dual Band FCC Class A ID: **PX8RX14V3-A** / FCC Class B ID: **PX8RX14V3-B**
- BDA Single Band FCC Class A ID: **PX8RX14V3S-A** / FCC Class B ID: **PX8RX14V3S-B**
- UL 2524 Standard Certified – SGS Certificate:
  - BDA Dual Band: **SGSNA/25/GZ/00025X**
  - BDA Single Band: **SGSNA/26/GZ/00034X**
  - BBU: **SGSNA/23/GZ/00235X**
  - System: **SGSNA/25/GZ/00331X**
- BDA Dual Band ISED (IC) Class A ID: **11919A-RX14V3A**/ISED (IC) Class B ID: **11919A-RX14V3-B**
- BDA Single Band ISED (IC) Class A ID: **11919A-RX14V3SA**/ISED (IC) Class B ID: **11919A-RX14V3S-B**
- UL50E Type 4/NEMA 4 enclosure for BDA/BBU.
- HCAI Listing: **OSP-0796**  
Category: Electrical Control Panels on Life Safety/Critical Branch, Sub-Category: Fire Alarm & Security Panels

## 1.2 V3 BDA MAIN FEATURES



Figure 3: V3 BDA Dual Band Cabinet – Front View



Figure 4: V3 BDA Single Band Cabinet– Front View

- Dual-band configuration supports VHF and UHF public safety bands for US and CA
- Supports single band VHF, single band UHF, or dual band VHF/UHF in one chassis
- Supports up to 3 Windows of UHF or 2 Windows of VHF frequencies in a single chassis
- Supports a combination of up to 3 UHF Windows and 1 VHF Window in same chassis
- Simplex and Duplexed configurations available
- Single Band Single Window configurations utilize a reduced size cabinet for smaller footprint
- Supports P25 P1/P2, digital and conventional analog communications simultaneously
- Built-in, custom-tuned, cavity filtering to protect the unit from interference and minimize noise generation
- Up to 24 and 32 narrow band filter pairs for VHF or UHF, respectively (Class A)
- 3 sub-band filter pairs per band (Class B).
- Channelized (Class A) with Downlink and Uplink AGC per channel/timeslot and wideband ALC.
- Downlink and Uplink squelch per channel/timeslot supported.
- NetProtect™ Uplink PA shutdown during idle periods to minimize noise being introduced to the network.
- Built-in mandatory isolation test to prevent BDA oscillation.
- Oscillation Detection with Auto-Gain Correction and Automatic PA Shutdown.
- Expandable to V3 VHF/UHF NG fiber system.
- Web based GUI for intelligent configuration, SNMP v2c/v3 supported.
- Integrated Battery Charger Unit, Comba BBU V3 supported.
- NFPA / IFC / UL 2524 compliant with dry contact alarms and built-in visual / audio annunciator.
- OSHPD Special Seismic Certification Preapproval (OSP) listed
- Additional external Comba Annunciator Panel V1 and V3 supported.

### 1.3 V3 BDA RF SPECIFICATIONS

		VHF	UHF
Passband (Downlink / Uplink) Certified by FCC / ISED	MHz	FCC: 150.05 – 173.4 ISED (IC): 138 – 144, 148 - 174	FCC: 406 - 420, 421 – 430, 450 - 512 ISED (IC): 406.1 - 430, 450 – 470
Passband Special Version: RX04V3-BOS	MHz	NA	DL: 483.1 - 483.3 UL: 486.1 - 486.3
Passband Special Version: RX04V3-MAM	MHz	NA	DL: 452.8 - 453.8 / 460.3 - 461.4 UL: 457.8 - 458.8 / 465.3 - 466.4
Total Output Power, Uplink	dBm	24 (including duplexers / filters)	27 (including duplexers / filters)
Total Output Power, Downlink	dBm	24 (including duplexers / filters)	30 (including duplexers / filters)
Maximum System Gain (Uplink / Downlink)	dB	85 (including duplexers / filters)	85 (including duplexers / filters)
Gain Adjustment Range (1dB step)	dB	30	30
Pass Band Ripple, p-p (Uplink / Downlink)	dB	4 (including duplexers / filters)	4 (including duplexers / filters)
Uplink Noise Figure	dB	<9 (Max gain including duplexers / filters)	
Intermodulation	dBm	FCC/ISED (IC) Compliance	FCC/ISED (IC) Compliance
Spurious	dBm	FCC/ISED (IC) Compliance	FCC/ISED (IC) Compliance
Max. RF Input Level without AGC (DL&UL)	dBm	-44 (w/o duplexers / filters)	-45 (w/o duplexers / filters)
Max. RF Input Level without Damage (DL&UL)	dBm	0 (w/o duplexers / filters)	0 (w/o duplexers / filters)
Max. RF Input Level without Overdrive (DL&UL)	dBm	-10 (w/o duplexers / filters)	-10 (w/o duplexers / filters)
Input VSWR		≤ 2	≤ 2
Impedance	Ω	50	50

<b>Class A Filtering Specifications</b>			
Number of Filters		24 pairs for VHF and 32 pairs for UHF	
Filter Passband Definition		3dB	
Filter Bandwidth		kHz	
		12.5/25/75	
Filters	Bandwidth (kHz)	Delay(μs)*	Out-of-Band Suppression
	12.5	≤90	≥ 60dBc @ filter edge +/- 30kHz
	25	≤48	≥ 60dBc @ filter edge +/- 50kHz
	75	≤18	≥ 60dBc @ filter edge +/- 130kHz

\*Actual delay numbers vary according to firmware version

<b>Class B Wide Band Filtering</b>			
Number of Filters		3 (shared by VHF and UHF)	
Filter Passband Definition		3dB	
Filter Bandwidth		MHz	0.2 - 5
System Group Delay		μsec*	≤ 7
Out-of-Band Suppression		dBc	≥ 60 @ filter edge +/- 600KHz

\*Actual delay numbers vary according to firmware version

## 1.4 V3 BDA MECHANICAL SPECIFICATIONS

Dimensions, H x W x D (with bracket) – Dual Band Chassis	mm / in	760 x 650 x 375 / 30.0 x 25.7 x 14.8
Dimensions, H x W x D (with bracket) – Single Band Chassis	mm / in	760 x 400 x 360 / 30.0 x 15.8 x 14.2
Weight without filters – Dual Band Chassis	kg / lbs	41.8 / 92.2
Weight without filters – Single Band Chassis	kg / lbs	35.8 / 78.9
Power Supply Input	VAC	100-240V / 50-60Hz / 4.5A Max
	VDC	+51.2V / 8A Max (Does NOT Support Negative DC Source)
DC Output Voltage to External Device, Nominal	VDC	+51.2VDC (1x), +28VDC (2x)
External Device Maximum Power Draw Supported	W	80
Maximum Charging Current	A	5
Power Consumption Single Band / Dual Band	W	<100 (Single Band), <120 (Dual Band)
Enclosure Cooling		Convection
Heat Dissipation	BTU/Hr	<535 (Dual Band Unit only, 2A Charging), < 620 (200W Load)
Main RF Connectors		4 x Ports for Donor Side, 4 x Ports for Mobile Side
RF Connectors for Fiber DAS expansion		1 x UHF/VHF DL Coupling, 1 x UHF/VHF UL Coupling
Aux / Expansion Ports (SMA Connectors)		Redundancy Ports x 8
RF Test Port		NA
Dry Contact Alarm Visual Annunciation		10 LEDs (LED test supported)
Dry Contact Alarm Audible Annunciation		Buzzer (Mute supported)
Communication port		RJ45 (LAN, OMT)
Dry Contact Alarm Output		8
Annunciator Panel		1 x Built-in, 4 x External Comba Annunciator Panel V1/V3 Supported
External Alarm Input		5 (#5 is pre-configured for Door Open Alarm)
Reserved Knockouts		3/4-inch hole x 6, 1/2-inch hole x 2, 1-inch hole x2
Operating Temperature and Humidity	°F (°C)	-40 to 131 (-40 to 55), ≤ 95%
Recommended Operating Temperature and Humidity	°F (°C)	45 to 80 (7.2 to 26.7), ≤ 65%
Environmental Class		UL50E Type 4 / NEMA 4
MTBF	Hr	100,000

## 1.5 V3 BBU MAIN FEATURES



Figure 5: V3 BBU – Front View



Figure 6: V3 BBU – Isometric View

- Optional, dedicated Battery Backup Solution for V3/NG platform.
- Powered by Lithium Iron Phosphate (LiFePO<sub>4</sub>) batteries.
- Provides 0 - 24 hours of backup time with 30Ah, 60Ah, and 100Ah battery options.
- Provides connections for EPO (Emergency Power Off) switch.
- Provides 2 x convenient AC outlets inside BBU for use during commissioning.

## 1.6 V3 BBU MECHANICAL SPECIFICATIONS

Dimensions, H x W x D	mm / in	605 x 500 x 272.9 / 23.8 x 19.7 x 10.7
Weight (without battery)	Kg / lbs	26 / 57.3
Reserved Knockouts		3/4-inch hole x 4, 1/2-inch hole x 6
Heat Dissipation	BTU/Hr	<100 (with 30AH, 60AH, or 100AH battery)
Operating Temperature and Humidity	°F (°C)	32 to 104 (0 to 40), ≤ 95%
Recommended Operating Temperature and Humidity	°F (°C)	45 to 80 (7.2 to 26.7), ≤ 65%
Enclosure Environmental Class		UL50E Type 4 / NEMA 4
MTBF	Hr	100,000

## 1.7 V3 BBU LIFEPO<sub>4</sub> BATTERY SPECIFICATIONS

Battery Type		(Lithium Iron Phosphate) LiFePO <sub>4</sub>		
System Required Quantity	pcs	1	1	1
Capacity, Discharge @ 0.33C	AH	30	60	100
Nominal Voltage	VDC	51.2	51.2	51.2
Charging@2A, from 30%	Hour	10.5	21	35
Backup Hours		48.1 * 30 / Load	48.1 * 60 / Load	48.1 * 100 / Load
Battery Weight	lb(kg)	52.9 (24)	79.8 (36.2)	123.5 (56)
Battery Electrolyte Counts		0.456 Gallons / 4.6 lbs	0.913 Gallons / 9.1 lbs	1.758 Gallons / 17.6 lbs
BMS Comm. Port		Serial port (RS485)		

\*Typical specifications at room temperature

**Note: See Appendix F for OEM Battery datasheets and Appendix I for Backup Runtime Calculations.**

## 1.8 V3 MU/RU/BBU FIBER DAS SYSTEM STANDARDS COMPLIANCE

- Complies with IFC / NFPA / UL2524 3<sup>rd</sup> Revision
- Master Unit Dual Band Chassis FCC Class A ID: **PX8RX14V3-A** / FCC Class B ID: **PX8RX14V3-B**
- Master Unit Single Band Chassis FCC Class A ID: **PX8RX14V3S-A** / FCC Class B ID: **PX8RX14V3S-B**
- Remote Unit FCC Class A ID: **PX8RH14V3-A** / FCC Class B ID: **PX8RH14V3-B**
- UL 2524 Standard Certified – SGS Certificate:
  - Master Unit (BDA): Dual Band Chassis: **SGSNA/25/GZ/00025X**
  - Master Unit (BDA): Single Band Chassis: **SGSNA/26/GZ/00034X**
  - Remote Unit: **SGSNA/23/GZ/00321X**
  - BBU: **SGSNA/23/GZ/00235X**
  - System: **SGSNA/25/GZ/00331X**
- Master Unit Dual Band Chassis ISED (IC) Class A ID: **11919A-RX14V3A**
- Master Unit Dual Band Chassis ISED (IC) Class B ID: **11919A-RX14V3B**
- Master Unit Single Band Chassis ISED (IC) Class A ID: **11919A-RX14V3SA**
- Master Unit Single Band Chassis ISED (IC) Class B ID: **11919A-RX14V3SB**
- Remote Unit ISED (IC) Class A ID: **11919A-RH14V3A** / ISED (IC) Class B ID: **11919A-RH14V3B**
- UL50E Type 4/NEMA 4 enclosure for BDA/RU/BBU.
- HCAI Listing: **OSP-0796**  
Category: Electrical Control Panels on Life Safety/Critical Branch, Sub-Category: Fire Alarm & Security Panels

## 1.9 V3 MU/FOU/RU FIBER DAS MAIN FEATURES



Figure 7: V3 BDA/MU – Front View



Figure 8: V2 FOU - Front and Isometric View



Figure 9: V3 RU – Front and Isometric View

- Dual-band configuration supports VHF and UHF public safety bands for US and CA
- Supports single band VHF, single band UHF, or dual band VHF/UHF in one chassis
- Supports up to 3 Windows of UHF or 2 Windows of VHF frequencies in a single chassis
- Supports a combination of up to 3 UHF Windows and 1 VHF Window in same chassis
- Simplex and Duplexed configurations available
- Single Band Single Window configurations utilize a reduced size cabinet for smaller footprint
- Supports P25 P1/P2, digital and conventional analog communications simultaneously.
- Built-in, custom-tuned, cavity filtering to protect the unit from interference and minimize noise generation
- Each BDA/Master can support up to 4 Fiber Optic Expansion Units and 32 Remote Units.
- Both Master Unit and Remote Units have the same output power for coverage.
- Up to 24 and 32 narrow band filter pairs for VHF or UHF, respectively (Class A)
- 5 sub-band filter pairs shared between VHF and UHF bands (Class B).
- Channelized (Class A) with Downlink and Uplink AGC per channel/timeslot and wideband ALC.
- Downlink and Uplink squelch per channel/timeslot supported.
- NetProtect™ Uplink PA shutdown during idle periods to minimize noise being introduced to the network.
- Built-in mandatory isolation test to prevent system oscillation.
- Oscillation Detection with Auto-Gain Correction and Automatic PA Shutdown.
- Web based GUI for intelligent configuration, SNMP v2c/v3 supported.
- Dual Fiber-Fed Remote Units can support Headend redundancy.
- Integrated Battery Charger Unit, Comba BBU V2 and BBU V3 supported.
- NFPA / IFC / UL 2524 compliant with dry contact alarms and built-in visual / audio annunciator.
- Additional external Comba Annunciator Panel V1 and V3 supported.

## 1.10 V2 FOU RF AND FIBER SPECIFICATIONS

Frequency Band	MHz	138 - 512
Optical Wavelength Uplink	nm	1310
Optical Wavelength Downlink	nm	1550
Optical Connector Type		SC-APC
Optical Fiber Type		Single Mode, WDM (single strand of fiber per Remote Units)
End to End Optical Loss	dBo	≤ 6.5
End to End Reflectance	dB	≤ -60
NOTE: All patch panels used between the Fiber Optic Unit and Remote Units must use SC/APC connectors or be fiber-sliced, no LC/UPC connectors can be utilized in the fiber path between equipment		
Number of RU supported per FOU		Up to 4 or 8 RU
Number of FOU supported per MU		Up to 4

## 1.11 V2 FOU MECHANICAL SPECIFICATIONS

Dimensions, H x W x D		in(mm)	18.5 x 15.8 x 3.4 (470 x 400 x 87)
Weight (without bracket)	4 Port / 8 Port	lb(kg)	25.4 (11.5) / 27.6 (12.5)
Power Consumption (approx.)	4 Port / 8 Port	W	15 / 20
Power Supply		VDC	+28 (From Master Unit)
Enclosure Cooling			Convection
Heat Dissipation		BTU/Hr	<35 (4 Port), <52 (8 Port)
Operating Temperature		°F (°C)	-40 to +131 (-40 to 55)
Operating Humidity			≤ 95%
Recommended Operating Temperature and Humidity		°F (°C)	45 to 80 (7.2 to 26.7), ≤ 65%
Enclosure Class			UL50E Type 4 / NEMA 4

Note: Typical specifications at room temperature

## 1.12 V3 MU/RU SYSTEM RF SPECIFICATIONS

		VHF	UHF
Passband (Downlink / Uplink) Certified by FCC / ISED	MHz	FCC: 150.05 – 173.4 ISED (IC): 138 -144, 148 - 174	FCC: 406.1 - 420, 421 – 430. 450 - 512 ISED (IC): 406.1 - 430, 450 – 470
Passband Special Version: RX04V3-BOS / RH04V3-BOS	MHz	NA	DL: 483.1 - 483.3 UL: 486.1 - 486.3
Passband Special Version: RX04V3-MAM / RH04V3-MAM	MHz	NA	DL: 452.8 - 453.8 / 460.3 - 461.4 UL: 457.8 - 458.8 / 465.3 - 466.4
Total Output Power, Uplink (MU Only)	dBm	24 (including duplexers / filters)	27 (including duplexers / filters)
Total Output Power, Downlink (MU or RU)	dBm	24 (including duplexers / filters)	30 (including duplexers / filters)
Maximum System Gain (Uplink / Downlink)	dB	85 (including duplexers / filters)	85 (including duplexers / filters)
Gain Adjustment Range (1dB step) **	dB	30	30
Pass Band Ripple, p-p (Uplink / Downlink)	dB	4 (including duplexers / filters)	4 (including duplexers / filters)
Uplink Noise Figure	dB	<9 (Max gain including duplexers / filters)	
Intermodulation	dBm	FCC/ISED (IC) Compliance	FCC/ISED (IC) Compliance
Spurious	dBm	FCC/ISED (IC) Compliance	FCC/ISED (IC) Compliance
Max. RF Input Level without AGC (DL&UL)	dBm	-44 (w/o duplexers / filters)	-45 (w/o duplexers / filters)
Max. RF Input Level without Damage (DL&UL)	dBm	0 (w/o duplexers / filters)	0 (w/o duplexers / filters)
Max. RF Input Level without Overdrive (DL&UL)	dBm	-10 (w/o duplexers / filters)	-10 (w/o duplexers / filters)
Input VSWR		≤ 2	≤ 2
Impedance	Ω	50	50

<b>Class A Filtering Specifications</b>			
Number of Filters			24 pairs for VHF and 32 pairs for UHF
Filter Passband Definition			3dB
Filter Bandwidth		KHz	12.5/25/75
	Bandwidth (kHz)	Delay(μs)*	Out-of-Band Suppression
Filters	12.5	≤90	≥ 60dBc @ filter edge +/- 30KHz
	25	≤48	≥ 60dBc @ filter edge +/- 50KHz
	75	≤18	≥ 60dBc @ filter edge +/- 130KHz

\*Actual delay numbers are various according to firmware version

<b>Class B Wide Band Filtering</b>			
Number of Filters			3 (shared by VHF and UHF)
Filter Passband Definition			3dB
Filter Bandwidth		MHz	0.2 - 5
System Group Delay		μsec*	≤ 7
Out-of-Band Suppression		dBc	≥ 60 @ filter edge +/- 600KHz

\*Actual delay numbers are various according to firmware version

### 1.13 V3 MU MECHANICAL SPECIFICATIONS

Dimensions, H x W x D (with bracket) – Dual Band Chassis	mm / in	760 x 650 x 375 / 30.0 x 25.7 x 14.8
Dimensions, H x W x D (with bracket) – Single Band Chassis	mm / in	760 x 400 x 360 / 30.0 x 15.8 x 14.2
Weight without filters – Dual Band Chassis	kg / lbs	41.8 / 92.2
Weight without filters – Single Band Chassis	kg / lbs	35.8 / 78.9
Power Supply Input	VAC	100-240V / 50-60Hz / 4.5A Max
	VDC	+51.2V / 8A Max (Does NOT Support Negative DC Source)
DC Output Voltage to External Device, Nominal	VDC	+51.2VDC (1x), +28VDC (2x)
External Device Maximum Power Draw Supported	W	80
Maximum Charging Current	A	5
Power Consumption Single Band / Dual Band	W	<100 (Single Band), <120 (Dual Band)
Enclosure Cooling		Convection
Heat Dissipation	BTU/Hr	<535 (Dual Band Unit only, 2A Charging), < 620 (200W Load)
Main RF Connectors		4 x Ports for Donor Side, 4 x Ports for Mobile Side
RF Connectors for Fiber DAS expansion		1 x UHF/VHF DL Coupling, 1 x UHF/VHF UL Coupling
Aux / Expansion Ports (SMA Connectors)		Redundancy Ports x 8
RF Test Port		NA
Dry Contact Alarm Visual Annunciation		10 LEDs (LED test supported)
Dry Contact Alarm Audible Annunciation		Buzzer (Mute supported)
Communication port		RJ45 (LAN, OMT)
Dry Contact Alarm Output		8
Annunciator Panel		1 x Built-in, 4 x External Comba Annunciator Panel V1/V3 Supported
External Alarm Input		5 (#5 is pre-configured for Door Open Alarm)
Reserved Knockouts		3/4-inch hole x 6, 1/2-inch hole x 2, 1-inch hole x2
Operating Temperature and Humidity	°F (°C)	-40 to 131 (-40 to 55), ≤ 95%
Recommended Operating Temperature and Humidity	°F (°C)	45 to 80 (7.2 to 26.7), ≤ 65%
Environmental Class		UL50E Type 4 / NEMA 4
MTBF	Hr	100,000

## 1.14 V3 RU MECHANICAL SPECIFICATIONS

Dimensions, H x W x D (with bracket)	mm / in	760 x 400 x 360 / 27.6 x 15.8 x 14.2
Weight without filters	kg / lbs	35.2 / 77.6
Power Supply Input	VAC	100-240V / 50-60Hz / 4.5A Max
	VDC	+51.2V / 8A Max (Does NOT Support Negative DC Source)
DC Output Voltage to External Device, Nominal	VDC	+51.2VDC (1x), +28VDC (2x)
External Device Maximum Power Draw Supported	W	80
Maximum Charging Current	A	5
Power Consumption Single Band / Dual Band	W	<90 (Single Band), <110 (Dual Band)
Enclosure Cooling		Convection
Heat Dissipation	BTU/Hr	<510 (Dual Band Unit only, 2A Charging), < 605 (200W Load)
Main RF Connectors		4 x Ports for Mobile Side
RF Connectors for Fiber DAS expansion		NA
Aux / Expansion Ports (SMA Connectors)		Redundancy Ports x 4
RF Test Port		NA
Dry Contact Alarm Visual Annunciation		10 LEDs (LED test supported)
Dry Contact Alarm Audible Annunciation		Buzzer (Mute supported)
Communication port		RJ45 (OMT)
Dry Contact Alarm Output		8
Annunciator Panel		1 x Built-in, 2 x External Comba Annunciator Panel V1/V3 Supported
External Alarm Input		5 (#5 is pre-configured for Door Open Alarm)
Reserved Knockouts		3/4-inch hole x 5, 1/2-inch hole x 1, 1-inch hole x1
Operating Temperature and Humidity	°F (°C)	-40 to 131 (-40 to 55), ≤ 95%
Recommended Operating Temperature and Humidity	°F (°C)	45 to 80 (7.2 to 26.7), ≤ 65%
Environmental Class		UL50E Type 4 / NEMA 4
MTBF	Hr	100,000

## 1.15 V3 SYSTEM PART NUMBERS EXPLAINED

### **RX14V3 – AP0 – VXXUXX**

	<b>UHF BDA Duplexer Filter Type</b>	SA, 1A, 1B, 1X, 2A, 2B, 2X, 3A
	<b>VHF BDA Duplexer Filter Type</b>	SA, 2A, 3A, 4A
	<b>BDA Power Supply</b>	P0 = AC input with internal charger
	<b>BDA Class</b>	A = Class A and Class B
	<b>BDA Authorized Band</b>	01 = VHF Band 04 = UHF Band 14 = VHF and UHF Dual Band
	<b>Master Unit / Remote Unit</b>	RX = Master Unit (BDA) RH = Remote Unit

<b>UHF Filter Descriptions</b>				
<b>Filter Type</b>	<b>Number of Windows</b>	<b>Filter Passband</b>	<b>Filter Guardband</b>	<b>Window to Window Guardband</b>
SA	N/A	Filters pass entire downlink passband or uplink passband for simplex units	N/A	N/A
1A	1	< 2.0MHz in 450-470MHz < 1.0MHz in 470-512MHz	≥ 3.0 MHz in 450-470 MHz or ≥ 2.0 MHz in 470-512 MHz	N/A
1B	1	< 2.5MHz in 450-470MHz < 1.5MHz in 470-512MHz	≥ 2.5 MHz in 450-470 MHz or ≥ 1.5 MHz in 470-512 MHz	N/A
1X	1	1 Window Customized Bandwidth, Confirm with Comba		
2A	2	Each window meets: < 2.0MHz in 450-470MHz or < 1.0MHz in 470-512MHz	Each window meets: ≥ 3.0 MHz in 450-470 MHz or ≥ 2.0 MHz in 470-512 MHz	> 3.0 MHz in 450-470 MHz or > 2.0 MHz in 470-512 MHz
2B	2	Each window meets: < 2.5MHz in 450-470MHz or < 1.5MHz in 470-512MHz	Each window meets: ≥ 2.5 MHz in 450-470 MHz or ≥ 1.5 MHz in 470-512 MHz	> 2.5 MHz in 450-470 MHz or > 1.5 MHz in 470-512 MHz
2X	2	2 Window Customized Bandwidth, Confirm with Comba		
3A	3	3 Window Customized Bandwidth, Confirm with Comba		
3X	3	3 Window Customized Bandwidth, Confirm with Comba		

VHF Filter Descriptions		
Filter Type	Description	Filter Limitation
SA	Simplex	Comba still provides filters to cover all channels, and additionally to provide rejections outside of these channels
2A	1 DL Window + 1 UL Window Duplexed	<p><math>\leq 3.5\text{MHz}</math> for passband for either DL window or UL window and <math>\geq 1.5\text{MHz}</math> guard band between the DL and UL filters</p> <p>*Comba can provide duplexed configuration for filter passband is <math>\geq 3.5\text{MHz}</math> or <math>\geq 1.5\text{MHz}</math> in the guard band for some markets. New PN is still under development, and these cases will be still quoted as 2A from the Comba portal before the new PN is released.</p>
3A	2 DL Windows + 1 UL Window or 1 DL Window + 2 UL Windows or 1 DL Window + 1 UL Window (Customized) Duplexed	Customized Bandwidth, Confirm with Comba
4A	2 DL Windows + 2 UL Windows 1 DL Window + 1 UL Window (Customized) Duplexed	Customized Bandwidth, Confirm with Comba
3B	2 DL Windows + 1 UL Window or 1 DL Window + 2 UL Windows (Customized) Duplexed	Customized Bandwidth, Confirm with Comba

<b>UHF Single Band BDA/Master Unit Configurations</b>		<b>Cabinet</b>
RX04V3-AP0-SA	UHF Single Band BDA V3, Class A/B, AC/DC, 30dBm DL, 27dBm UL, Filter Type = SA	Single Band
RX04V3-AP0-1A	UHF Single Band BDA V3, Class A/B, AC/DC, 30dBm DL, 27dBm UL, Filter Type = 1A	Single Band
RX04V3-AP0-1B	UHF Single Band BDA V3, Class A/B, AC/DC, 30dBm DL, 27dBm UL, Filter Type = 1B	Single Band
RX04V3-AP0-1X	UHF Single Band BDA V3, Class A/B, AC/DC, 30dBm DL, 27dBm UL, Filter Type = 1X	Single Band
RX04V3-AP0-2A	UHF Single Band BDA V3, Class A/B, AC/DC, 30dBm DL, 27dBm UL, Filter Type = 2A	Single Band
RX04V3-AP0-2B	UHF Single Band BDA V3, Class A/B, AC/DC, 30dBm DL, 27dBm UL, Filter Type = 2B	Single Band
RX04V3-AP0-2X	UHF Single Band BDA V3, Class A/B, AC/DC, 30dBm DL, 27dBm UL, Filter Type = 2X	Single Band
RX04V3-AP0-3A	UHF Single Band BDA V3, Class A/B, AC/DC, 30dBm DL, 27dBm UL, Filter Type = 3A	Single Band
RX04V3-AP0-3X	UHF Single Band BDA V3, Class A/B, AC/DC, 30dBm DL, 27dBm UL, Filter Type = 3X	Dual Band
<b>VHF Single Band BDA/Master Unit Configurations</b>		
RX01V3-AP0-SA	VHF Single Band BDA V3, Class A/B, AC/DC, 24dBm DL, 24dBm UL, Filter Type = SA	Single Band
RX01V3-AP0-2A	VHF Single Band BDA V3, Class A/B, AC/DC, 24dBm DL, 24dBm UL, Filter Type = 2A	Single Band
RX01V3-AP0-3A	VHF Single Band BDA V3, Class A/B, AC/DC, 24dBm DL, 24dBm UL, Filter Type = 3A	Single Band
RX01V3-AP0-4A	VHF Single Band BDA V3, Class A/B, AC/DC, 24dBm DL, 24dBm UL, Filter Type = 4A	Single Band
RX01V3-AP0-3B	VHF Single Band BDA V3, Class A/B, AC/DC, 24dBm DL, 24dBm UL, Filter Type = 3B	Single Band
RX01V3-AP0-5A	VHF Single Band BDA V3, Class A/B, AC/DC, 24dBm DL, 24dBm UL, Filter Type = 5A	Dual Band
<b>VHF and UHF Dual Band BDA/Master Unit Configurations</b>		
RX14V3-AP0-VSAUSA	VHF&UHF Dual Band BDA V3, Class A/B, AC/DC, VHF/UHF: 24/30dBm DL, 24/27dBm UL, VHF/UHF Filter Type: SA, SA	Dual Band
RX14V3-AP0-VSAU1A	VHF&UHF Dual Band BDA V3, Class A/B, AC/DC, VHF/UHF: 24/30dBm DL, 24/27dBm UL, VHF/UHF Filter Type: SA, 1A	Dual Band
RX14V3-AP0-VSAU1B	VHF&UHF Dual Band BDA V3, Class A/B, AC/DC, VHF/UHF: 24/30dBm DL, 24/27dBm UL, VHF/UHF Filter Type: SA, 1B	Dual Band
RX14V3-AP0-VSAU1X	VHF&UHF Dual Band BDA V3, Class A/B, AC/DC, VHF/UHF: 24/30dBm DL, 24/27dBm UL, VHF/UHF Filter Type: SA, 1X	Dual Band
RX14V3-AP0-VSAU2A	VHF&UHF Dual Band BDA V3, Class A/B, AC/DC, VHF/UHF: 24/30dBm DL, 24/27dBm UL, VHF/UHF Filter Type: SA, 2A	Dual Band
RX14V3-AP0-VSAU2B	VHF&UHF Dual Band BDA V3, Class A/B, AC/DC, VHF/UHF: 24/30dBm DL, 24/27dBm UL, VHF/UHF Filter Type: SA, 2B	Dual Band
RX14V3-AP0-VSAU2X	VHF&UHF Dual Band BDA V3, Class A/B, AC/DC, VHF/UHF: 24/30dBm DL, 24/27dBm UL, VHF/UHF Filter Type: SA, 2X	Dual Band
RX14V3-AP0-VSAU3A	VHF&UHF Dual Band BDA V3, Class A/B, AC/DC, VHF/UHF: 24/30dBm DL, 24/27dBm UL, VHF/UHF Filter Type: SA, 3A	Dual Band
RX14V3-AP0-V2AUSA	VHF&UHF Dual Band BDA V3, Class A/B, AC/DC, VHF/UHF: 24/30dBm DL, 24/27dBm UL, VHF/UHF Filter Type: 2A, SA	Dual Band
RX14V3-AP0-V2AU1A	VHF&UHF Dual Band BDA V3, Class A/B, AC/DC, VHF/UHF: 24/30dBm DL, 24/27dBm UL, VHF/UHF Filter Type: 2A, 1A	Dual Band
RX14V3-AP0-V2AU1B	VHF&UHF Dual Band BDA V3, Class A/B, AC/DC, VHF/UHF: 24/30dBm DL, 24/27dBm UL, VHF/UHF Filter Type: 2A, 1B	Dual Band
RX14V3-AP0-V2AU1X	VHF&UHF Dual Band BDA V3, Class A/B, AC/DC, VHF/UHF: 24/30dBm DL, 24/27dBm UL, VHF/UHF Filter Type: 2A, 1X	Dual Band
RX14V3-AP0-V2AU2A	VHF&UHF Dual Band BDA V3, Class A/B, AC/DC, VHF/UHF: 24/30dBm DL, 24/27dBm UL, VHF/UHF Filter Type: 2A, 2A	Dual Band
RX14V3-AP0-V2AU2B	VHF&UHF Dual Band BDA V3, Class A/B, AC/DC, VHF/UHF: 24/30dBm DL, 24/27dBm UL, VHF/UHF Filter Type: 2A, 2B	Dual Band
RX14V3-AP0-V2AU2X	VHF&UHF Dual Band BDA V3, Class A/B, AC/DC, VHF/UHF: 24/30dBm DL, 24/27dBm UL, VHF/UHF Filter Type: 2A, 2X	Dual Band
RX14V3-AP0-V2AU3A	VHF&UHF Dual Band BDA V3, Class A/B, AC/DC, VHF/UHF: 24/30dBm DL, 24/27dBm UL, VHF/UHF Filter Type: 2A, 3A	Dual Band
RX14V3-AP0-V3BU1A	VHF&UHF Dual Band BDA V3, Class A/B, AC/DC, VHF/UHF: 24/30dBm DL, 24/27dBm UL, VHF/UHF Filter Type: 3B, 1A	Dual Band

<b>UHF Single Band – Special BDA/Master Unit Configurations</b>		<b>Cabinet</b>
RX04V3-BOS	UHF Single Band BDA V3, Class A, AC/DC, 30dBm DL, 27dBm UL, Filter Type = BOS (Typically for Boston) <b>Passband: DL: 483.1 - 483.3MHz, UL: 486.1 - 486.3MHz</b>	Single Band
RX04V3-MDF	UHF Single Band BDA V3, Class A/B, AC/DC, 30dBm DL, 27dBm UL, Filter Type = MDF (Typically for Miami-Dade County) <b>Passband: DL: 452.8 - 453.8 / 460.3 - 461.4MHz, UL: 457.8 - 458.8 / 465.3 - 466.4MHz</b>	Single Band

<b>UHF Single Band Remote Units</b>	
RH04V3-AP0-SA	UHF Single Band RU V3, Class A/B, AC/DC, 30dBm DL, Filter Type = SA
RH04V3-AP0-1A	UHF Single Band RU V3, Class A/B, AC/DC, 30dBm DL, Filter Type = 1A
RH04V3-AP0-1B	UHF Single Band RU V3, Class A/B, AC/DC, 30dBm DL, Filter Type = 1B
RH04V3-AP0-1X	UHF Single Band RU V3, Class A/B, AC/DC, 30dBm DL, Filter Type = 1X
RH04V3-AP0-2A	UHF Single Band RU V3, Class A/B, AC/DC, 30dBm DL, Filter Type = 2A
RH04V3-AP0-2B	UHF Single Band RU V3, Class A/B, AC/DC, 30dBm DL, Filter Type = 2B
RH04V3-AP0-2X	UHF Single Band RU V3, Class A/B, AC/DC, 30dBm DL, Filter Type = 2X
RH04V3-AP0-3A	UHF Single Band RU V3, Class A/B, AC/DC, 30dBm DL, Filter Type = 3A
RH04V3-AP0-3X	UHF Single Band RU V3, Class A/B, AC/DC, 30dBm DL, Filter Type = 3X
<b>VHF Single Band Remote Units</b>	
RH01V3-AP0-SA	VHF Single Band RU V3, Class A/B, AC/DC, 24dBm DL, Filter Type = SA
RH01V3-AP0-2A	VHF Single Band RU V3, Class A/B, AC/DC, 24dBm DL, Filter Type = 2A
RH01V3-AP0-3A	VHF Single Band RU V3, Class A/B, AC/DC, 24dBm DL, Filter Type = 3A
RH01V3-AP0-4A	VHF Single Band RU V3, Class A/B, AC/DC, 24dBm DL, Filter Type = 4A
RH01V3-AP0-3B	VHF Single Band RU V3, Class A/B, AC/DC, 24dBm DL, Filter Type = 3B
RH01V3-AP0-5A	VHF Single Band RU V3, Class A/B, AC/DC, 24dBm DL, Filter Type = 5A
<b>VHF and UHF Dual Band Remote Units</b>	
RH14V3-AP0-VSAUSA	VHF&UHF Dual Band RU V3, Class A/B, AC/DC, VHF/UHF: 24/30dBm DL, VHF/UHF Filter Type: SA, SA
RH14V3-AP0-VSAU1A	VHF&UHF Dual Band RU V3, Class A/B, AC/DC, VHF/UHF: 24/30dBm DL, VHF/UHF Filter Type: SA, 1A
RH14V3-AP0-VSAU1B	VHF&UHF Dual Band RU V3, Class A/B, AC/DC, VHF/UHF: 24/30dBm DL, VHF/UHF Filter Type: SA, 1B
RH14V3-AP0-VSAU1X	VHF&UHF Dual Band RU V3, Class A/B, AC/DC, VHF/UHF: 24/30dBm DL, VHF/UHF Filter Type: SA, 1X
RH14V3-AP0-VSAU2A	VHF&UHF Dual Band RU V3, Class A/B, AC/DC, VHF/UHF: 24/30dBm DL, VHF/UHF Filter Type: SA, 2A
RH14V3-AP0-VSAU2B	VHF&UHF Dual Band RU V3, Class A/B, AC/DC, VHF/UHF: 24/30dBm DL, VHF/UHF Filter Type: SA, 2B
RH14V3-AP0-VSAU2X	VHF&UHF Dual Band RU V3, Class A/B, AC/DC, VHF/UHF: 24/30dBm DL, VHF/UHF Filter Type: SA, 2X
RH14V3-AP0-VSAU3A	VHF&UHF Dual Band RU V3, Class A/B, AC/DC, VHF/UHF: 24/30dBm DL, VHF/UHF Filter Type: SA, 3A
RH14V3-AP0-V2AUSA	VHF&UHF Dual Band RU V3, Class A/B, AC/DC, VHF/UHF: 24/30dBm DL, VHF/UHF Filter Type: 2A, SA
RH14V3-AP0-V2AU1A	VHF&UHF Dual Band RU V3, Class A/B, AC/DC, VHF/UHF: 24/30dBm DL, VHF/UHF Filter Type: 2A, 1A
RH14V3-AP0-V2AU1B	VHF&UHF Dual Band RU V3, Class A/B, AC/DC, VHF/UHF: 24/30dBm DL, VHF/UHF Filter Type: 2A, 1B
RH14V3-AP0-V2AU1X	VHF&UHF Dual Band RU V3, Class A/B, AC/DC, VHF/UHF: 24/30dBm DL, VHF/UHF Filter Type: 2A, 1X
RH14V3-AP0-V2AU2A	VHF&UHF Dual Band RU V3, Class A/B, AC/DC, VHF/UHF: 24/30dBm DL, VHF/UHF Filter Type: 2A, 2A
RH14V3-AP0-V2AU2B	VHF&UHF Dual Band RU V3, Class A/B, AC/DC, VHF/UHF: 24/30dBm DL, VHF/UHF Filter Type: 2A, 2B
RH14V3-AP0-V2AU2X	VHF&UHF Dual Band RU V3, Class A/B, AC/DC, VHF/UHF: 24/30dBm DL, VHF/UHF Filter Type: 2A, 2X
RH14V3-AP0-V2AU3A	VHF&UHF Dual Band RU V3, Class A/B, AC/DC, VHF/UHF: 24/30dBm DL, VHF/UHF Filter Type: 2A, 3A
RH14V3-AP0-V3BU1A	VHF&UHF Dual Band RU V3, Class A/B, AC/DC, VHF/UHF: 24/30dBm DL, VHF/UHF Filter Type: 3B, 1A

<b>UHF Single Band – Special Remote Unit Configurations</b>	
RH04V3-BOS	UHF Single Band RU V3, Class A, AC/DC, 30dBm DL, Filter Type = BOS (Typically for Boston) <b>Passband: DL: 483.1 - 483.3MHz, UL: 486.1 - 486.3MHz</b>
RH04V3-MDF	UHF Single Band RU V3, Class A/B, AC/DC, 30dBm DL, Filter Type = MAM (Typically for Miami-Dade County) <b>Passband: DL: 452.8 - 453.8 / 460.3 - 461.4MHz, UL: 457.8 - 458.8 / 465.3 - 466.4MHz</b>

**Fiber Optic Unit (FOU) Part Numbers**

<b>FOU Part Numbers</b>	<b>Description</b>
RHFOUV2F-VU-E04UL	Critical Point Fiber Optical Unit for platform VHF/UHF V3 NG, 4 port, UL 2524 Standard Certified
RHFOUV2F-VU-E08UL	Critical Point Fiber Optical Unit for platform VHF/UHF V3 NG, 8 port, UL 2524 Standard Certified

**Battery Backup Unit (BBU) Part Numbers**

<b>BBU Part Numbers</b>	<b>Battery Type</b>	<b>Capacity</b>	<b>Backup Hours</b>
BBUV3-LFP48030	Lithium iron phosphate	30AH	>12H for 110W
BBUV3-LFP48060	Lithium iron phosphate	60AH	>24H for 110W, 12H for 220W
BBUV3-LFP48100	Lithium iron phosphate	100AH	>48H for 110W, 24H for 220W

## 1.16 V3 BDA/MU FUNCTIONAL BLOCK DIAGRAM – DUAL BAND DUPLEXED

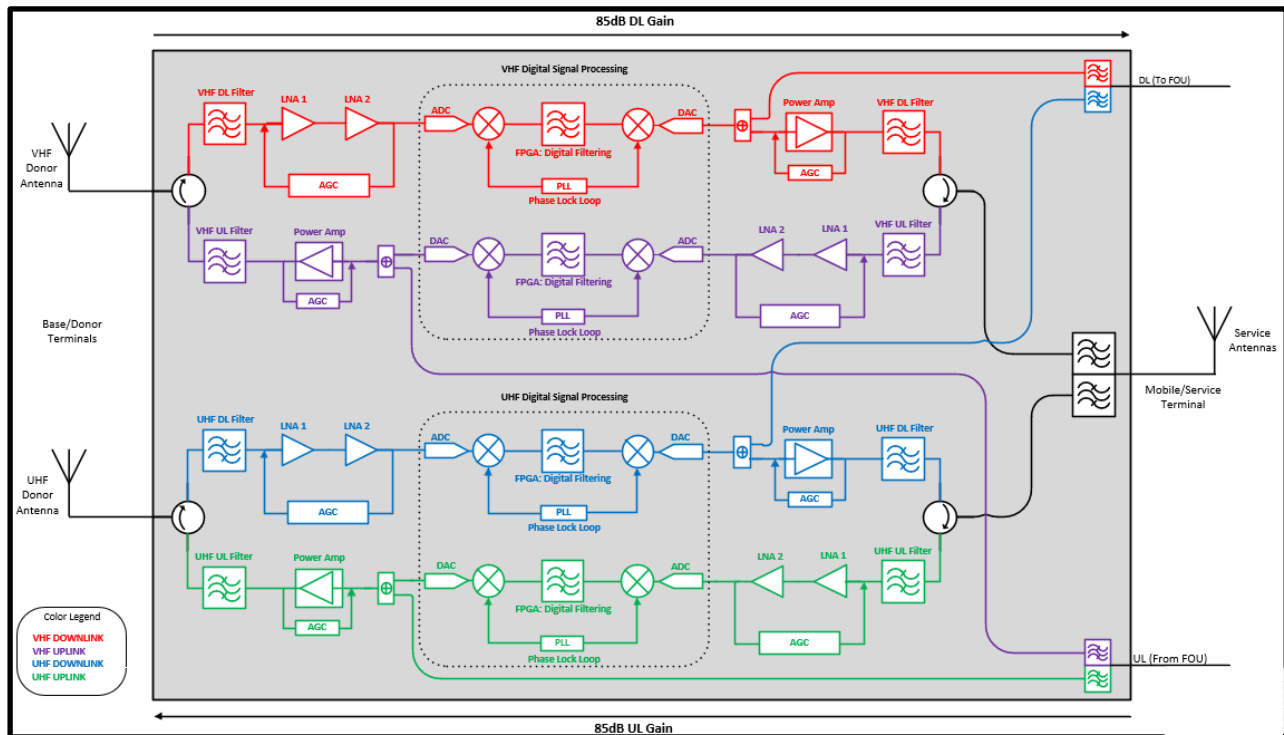

Figure 10: V3 BDA Functional Block Diagram – Duplexed

Note: The above block diagram shows the VHF DL path in Red, the UHF DL path in Blue, the VHF UL path in Purple, and the UHF UL path in Green.

In the downlink path, RF signals are received by the donor antennas from the tower sites and fed to the DT ports of the BDA. If the device is dual band, supporting both VHF and UHF bands, there will be a DT Port for each band, and the device will have separate amplification paths for each band, with a single combined VHF/UHF MT Port to easily feed into the inbuilding DAS. Once the downlink signal enters the DT Port of the device, the DT Duplexer/Circulator will separate the DL and UL signals so they can be conditioned separately. After the DT Duplexer/Circulator, the DL signals enter the Downlink Input Filter, which passes frequencies within the device passband and rejects/attenuates signals outside of the passband. After the Downlink Input Filter, the signal is sent to the LNA modules for pre-amplification and then pass to the digital RF integrated module for digital filtering and frequency conversion. Once the DL signals have been digitally processed, they enter the DL PA for a final gain boost to amplify to final target power. After amplification, the DL signals will enter the Downlink Output Filter, rejecting all wideband noise from the DL PA, and only passing the desired signals within the device frequency passbands. The DL signals then enter the MT Duplexer/Circulator for final combining. In the case of a dual band VHF/UHF BDA, the DL signals from each band are then combined from their Duplexer/Circulators using a crossband coupler/diplexer. The DL signals are finally transmitted at the MT port towards service antenna(s). Additionally, when in a fiber DAS configuration, DL signals are coupled internally before the DL PA to feed the DL FOU port which is used in fiber DAS applications to feed the Fiber Optic Expansion Unit (FOU).

In the uplink path, the mobile RF signals from portable radios are received by the service antenna(s) and travel through a network of passive devices before entering the BDA at the MT port. The MT Crossband Coupler/Diplexer will then split/separate the VHF and UHF UL Signals to feed their respective paths. The MT Duplexer/Circulator for each band will separate the DL and UL signals so they can be conditioned separately. After the MT Duplexer/Circulator, the UL signals enter the Uplink Input Filter, which passes frequencies within the device passband and rejects/attenuates signals outside of the passband. After the UL Input Filter, the signals enter the LNA module for pre-amplification and then pass to the digital RF integrated module for digital

filtering and frequency conversion. Once the UL signals have been digitally processed, they enter the UL PA for a final gain boost to amplify to final target power. After amplification, the UL signals will enter the UL Output Filter for final filtering, rejecting all wideband noise from the UL PA, and only passing the desired signals within the device passbands. The UL signals then enter the DT Duplexer/Circulator for final combining. The UL signals are finally transmitted at the DT port towards the donor antenna and to the PS radio site. Additionally, when in a fiber DAS configuration, UL signals received from the Fiber Optic Expansion Unit (FOU) are fed into the BDA through the UL FOU port and coupled into the UL path before the UL PA.

### 1.17 V3 BDA/MU FUNCTIONAL BLOCK DIAGRAM – DUAL BAND SIMPLEX

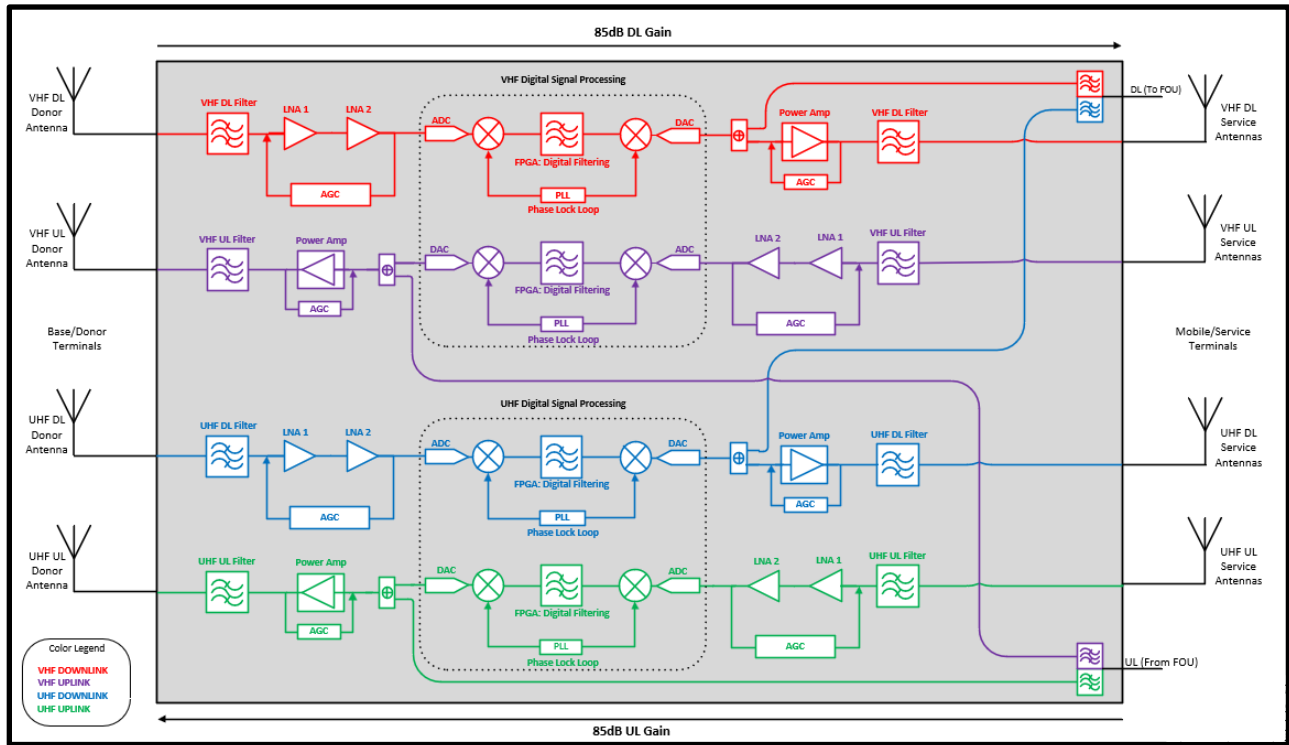

Figure 11: V3 BDA Functional Block Diagram - Simplex

Note: The above block diagram shows the VHF DL path in Red, the UHF DL path in Blue, the VHF UL path in Purple, and the UHF UL path in Green.

In the Simplex BDA configuration, DL and UL signals are conditioned in the same manner as the duplexed BDA. See Section 1.16 and Figure 10. However, In the Simplex configuration, Duplexer/Circulators are not included, providing separate DL and UL paths for each band. This configuration is typically used when frequency configurations are too complex to provide proper internal filtering, and a split DAS with separated DL and UL antenna networks is utilized. On the Base/Donor side of the BDA, each band will have a separate DT Port for DL and UL (VHF DL IN, VHF UL OUT, UHF DL IN, UHF UL OUT). On the Mobile/Service side of the BDA, each band will have a separate MT Port for DL and UL (VHF DL OUT, VHF UL IN, UHF DL OUT, UHF UL IN). The system must be designed, commissioned, and optimized with proper port-to-port isolation between all ports to prevent oscillation.

## 1.18 V3 MU – FOU FUNCTIONAL BLOCK DIAGRAM – DUAL BAND DUPLEXED

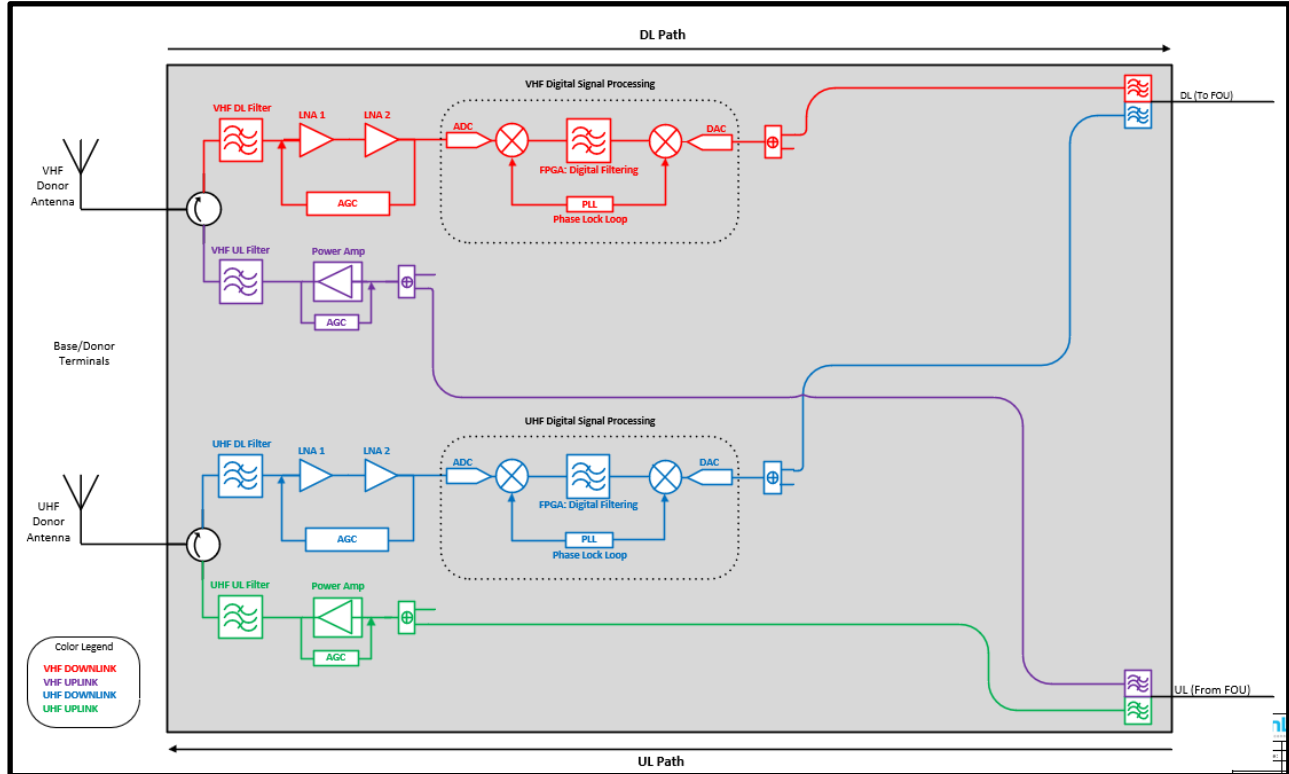

Figure 12: V3 MU to FOU Functional Block Diagram

Note: The above block diagram shows the VHF DL path in Red, the UHF DL path in Blue, the VHF UL path in Purple, and the UHF UL path in Green.

Note: The BDA and MU are the same device. The only difference is the software configuration. When using the device in a fiber DAS configuration, the software must be in “DAS” mode for correct operation. DL OUT FOU and UL IN FOU ports located on the BDA/MU are used to interconnect to the Fiber Optic Expansion Unit (FOU). For simplicity, BDA components not related to the end-to-end Fiber DAS RF paths have been omitted from Figure 12.

If the device is dual band, supporting both VHF and UHF bands, there will be a DT Port for each band, and the device will have separate amplification paths for each band, with a single combined VHF/UHF MT Port to easily feed into the inbuilding DAS. Once the downlink signal enters the DT Port of the device, the DT Duplexer/Circulator will separate the DL and UL signals so they can be conditioned separately. After the DT Duplexer/Circulator, the signals enter the Downlink Input Filter, which passes frequencies within the device passband and rejects/attenuates signals outside of the passband. After the Downlink Input Filter, the signal is sent to the LNA modules for pre-amplification and then pass to the digital RF integrated module for digital filtering and frequency conversion. Once the DL signals have been digitally processed, the VHF and UHF DL signals are coupled off before their DL PAs and are combined to feed the DL OUT FOU port. The DL signals are finally transmitted at the DL OUT FOU port towards the FOU.

In the uplink path, the UL signals received from the FOU are fed into the BDA/MU through the UL IN FOU port, the MT Crossband Coupler/Diplexer splits/separate the VHF and UHF UL Signals to feed their respective paths and then coupled into each band’s UL path before the UL PA. Then the UL signals enter the UL PA for a final gain boost to amplify to final target power. After amplification, the UL signals will enter the UL Output Filter for final filtering, rejecting all wideband noise from the UL PA, and only passing the desired signals within the

device passbands. The UL signals then enter the DT Duplexer/Circulator for final combining. The UL signals are finally transmitted at the DT port towards the donor antenna and to the PS radio site.

## 1.19 V2 FOU FUNCTIONAL BLOCK DIAGRAM

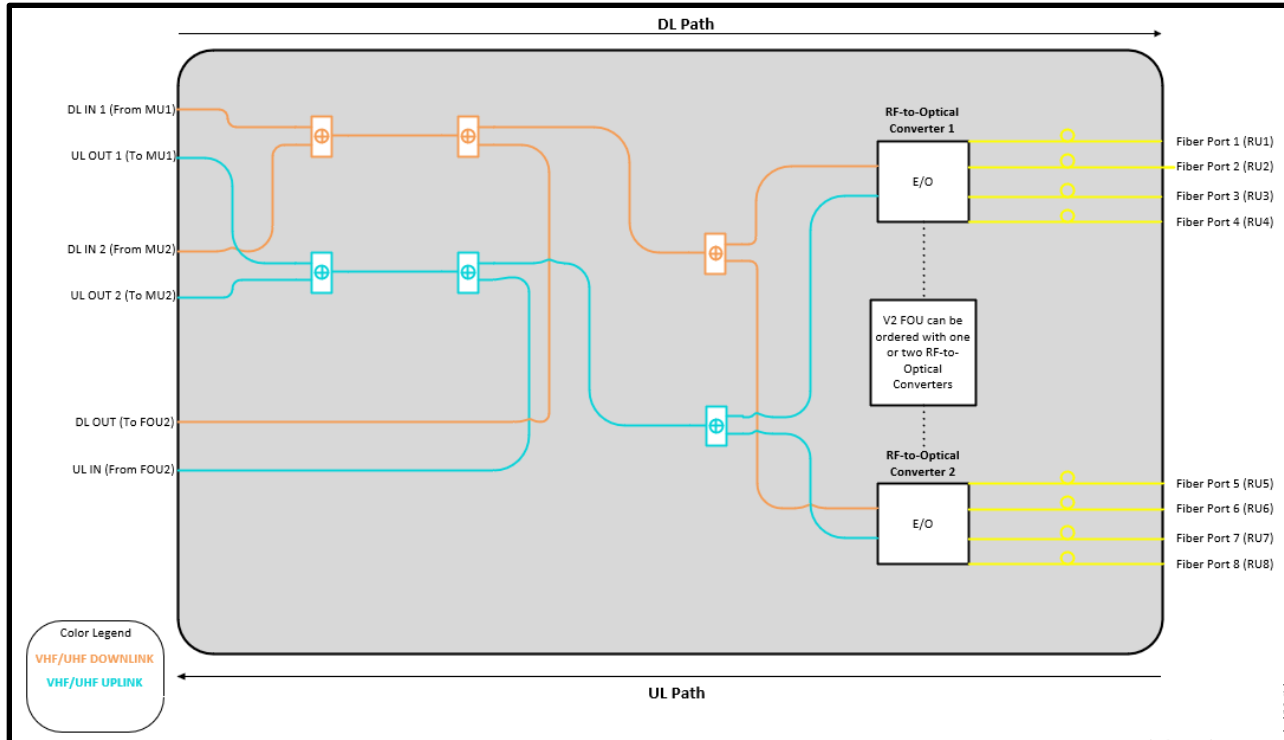

Figure 13: V2 FOU Functional Block Diagram

Note: The above block diagram shows the VHF/UHF DL path in Orange, the VHF/UHF UL path in Teal, and the Fiber Optic paths in Yellow.

There are two DL IN and two UL OUT ports on the FOU. The purpose is to allow two BDA/MU's to feed signals to and from the FOU to provide redundancy. This redundancy functionality is not currently available but is planned for release in the future. For now, always connect the BDA/MU FOU connections to the DL IN 1 and UL OUT 1 FOU ports.

There is a DL OUT and UL IN (DL\_E and UL\_E) port on the FOU. These ports are used to interconnect to additional FOU devices for further system expansion. You can daisy-chain up to 4 FOU's from a single BDA/MU. Each FOU can be ordered/configured to have one or two RF-to-optical converters and can support 4 or 8 RUs. Each RF-to-Optical converter module can support up to 4 RUs. A fully loaded system can support 32 RUs from a single BDA/MU using 4 FOU's, each with 2 RF-to-Optical converters.

In the downlink path, the DL signals are received from the BDA/MU at the DL IN port of the FOU. Once the DL signals enter the FOU from DL IN 1 and DL IN 2, they are combined and fed to the RF-to-Optical converter(s). Once the DL signals reach the RF-to-Optical converters, they are converted from an RF signal to an optical signal and transmitted down the fiber to be received by the RU.

In the uplink path, the UL optical signals received from the RUs are fed to the RF-to-Optical converter and converted to an RF signal. The UL signals are then combined with UL Signals from other FOU's and fed towards the FOU UL OUT ports. Finally, the UL signals are transmitted from the UL OUT ports towards the BDA/MU FOU UL IN port.

## 1.20 V3 RU FUNCTIONAL BLOCK DIAGRAM – DUAL BAND DUPLEXED

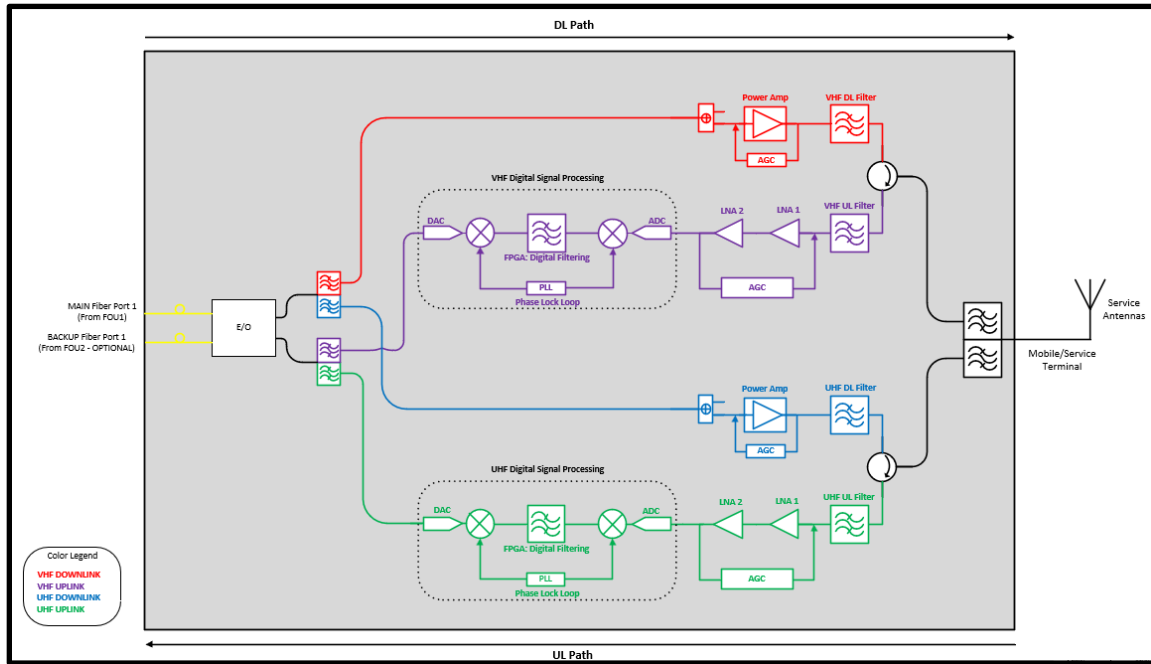

Figure 14: V3 RU Functional Block Diagram

Note: The above block diagram shows the VHF DL path in Red, the UHF DL path in Blue, the VHF UL path in Purple, and the UHF UL path in Green.

There are two Fiber optic ports installed on the V3 RU. The purpose is to allow for system redundancy for two MU/FOU's to feed signals to and from the RU. There is a MAIN Fiber Port 1 and an OPTIONAL BACKUP Fiber Port 2. When redundancy mode is activated, during normal operation, when all devices are free from alarms, the RU will Transmit/Receive signals from the MAIN Fiber Port 1. Upon a fiber failure on the MAIN Fiber Port 1, the RU will automatically switch and Transmit/Receive signals on the BACKUP Fiber Port 2. Additionally, MU Dry Contact alarm can be configured such that user defined MU alarms can feed into an external alarm input and trigger the RU to switch to the BACKUP Fiber Port 2. In other words, the user has control of which MU alarms will cause the RU to switch to its BACKUP fiber path. These redundancy features are currently not available but are planned for release in the future. For now, always connect the fiber to the MAIN Fiber Port 1 for standard applications.

In the downlink path, the DL optical signals are received on the MAIN Fiber Port 1 of the RU. Once the DL signals enter the RU they are fed to the RF-to-Optical converter. Once the DL signals reach the RF-to-Optical converters, they are converted from Optical signals to RF signals. The VHF and UHF bands are then separated using a Crossband Coupler/Diplexer, and DL Signals are fed towards the DL PAs for final amplification. After amplification, the DL signals will enter the Downlink Output Filter, rejecting all wideband noise from the DL PA, and only passing the desired signals within the device frequency passbands. The DL signals then enter the MT Duplexer/Circulator for final combining. In the case of a dual band VHF/UHF RU, the DL signals from each band are then combined from their Duplexer/Circulators using a crossband coupler/diplexer. The DL signals are finally transmitted at the MT port towards service antenna(s).

In the uplink path, the mobile RF signals from portable radios are received by the service antenna(s) and travel through a network of passive devices before entering the BDA at the MT port. The MT Crossband Coupler/Diplexer will then split/separate the VHF and UHF UL Signals to feed their respective paths. The MT Duplexer/Circulator for each band will separate the DL and UL signals so they can be conditioned separately. After the MT Duplexer/Circulator, the UL signals enter the Uplink Input Filter, which passes frequencies within the device passband and rejects/attenuates signals outside of the passband. After the UL Input Filter, the signals enter the LNA module for pre-amplification and then pass to the digital RF integrated module for digital

filtering and frequency conversion. Once the UL signals have been digitally processed, they are fed to the RF-to-Optical converter to be converted to an optical signal and are transmitted towards the FOU on the MAIN Fiber port.

### 1.21 V3 BDA/MU DUAL BAND CABINET DIMENSIONS

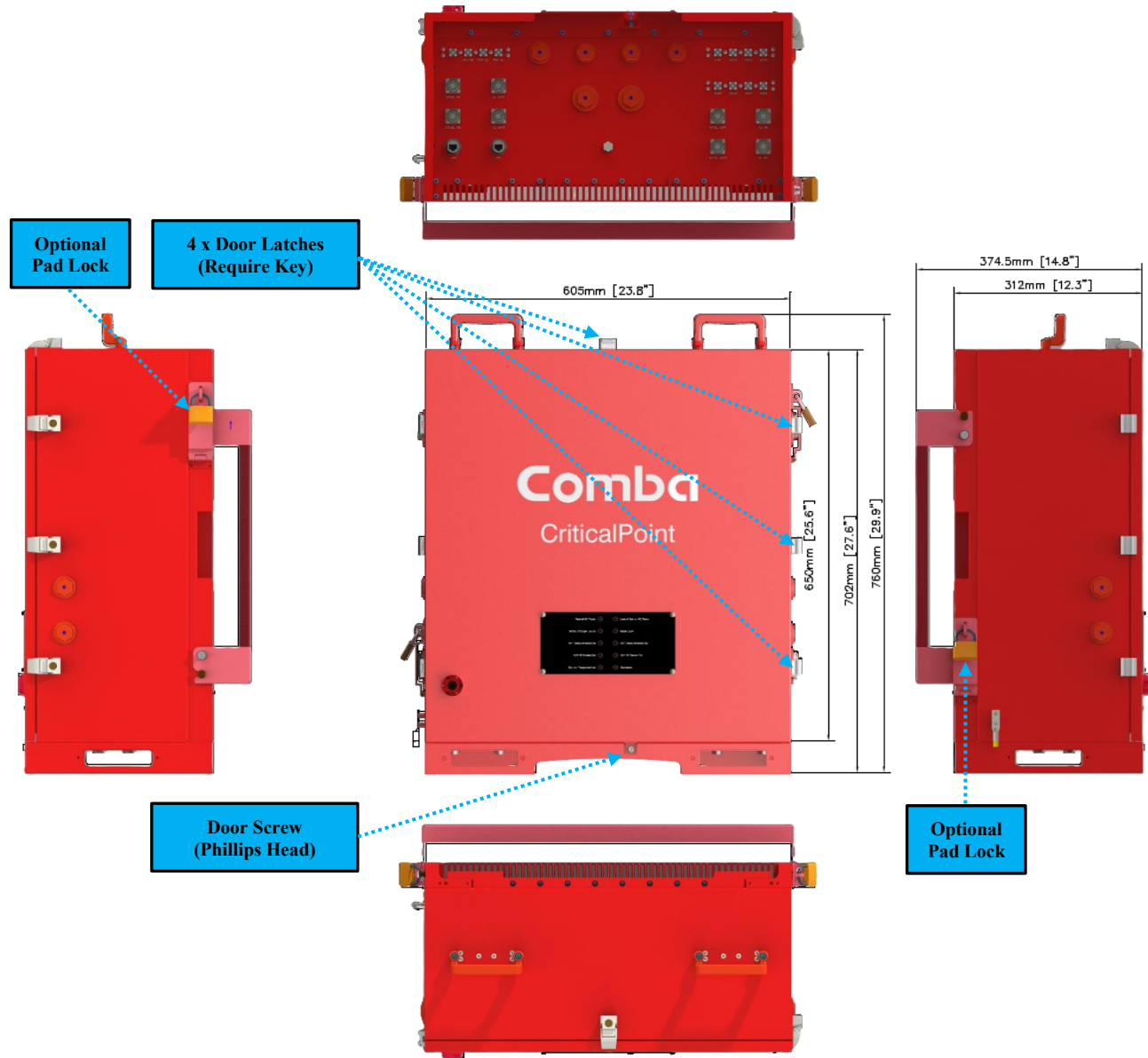

Figure 15: V3 BDA/MU Dual Band Cabinet Dimensions – Front, Side, Top and Bottom View

## 1.22 V3 BDA/MU DUAL BAND CABINET MOUNTING BRACKET DIMENSIONS

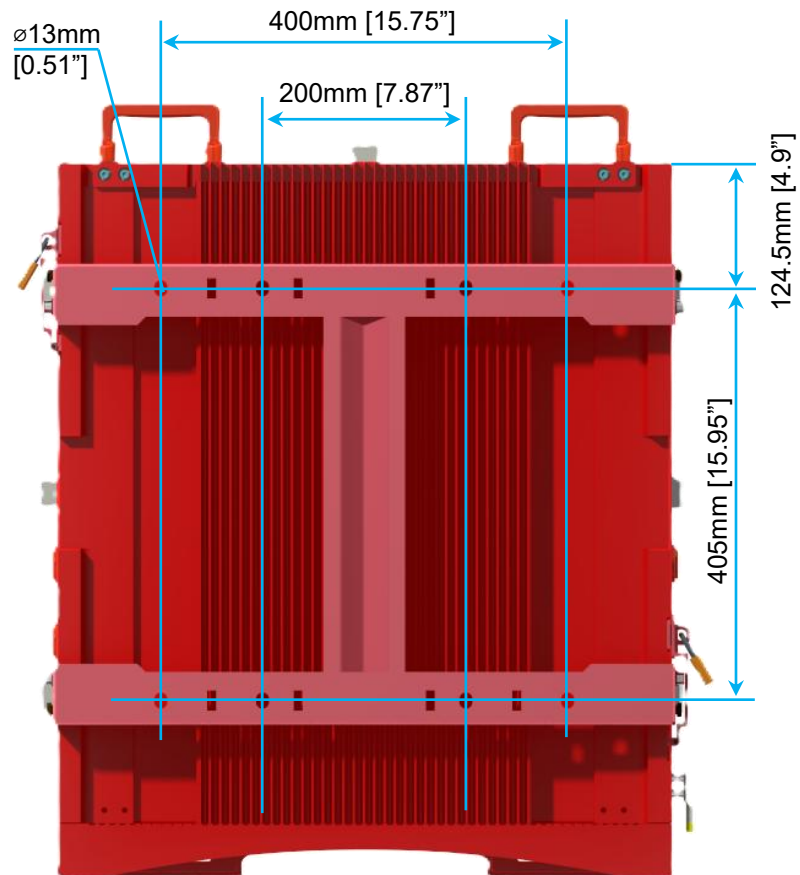

Figure 16: V3 BDA/MU Dual Band Cabinet Mounting Bracket Dimensions

1.23 V3 BDA/MU DUAL BAND CABINET CONNECTIONS

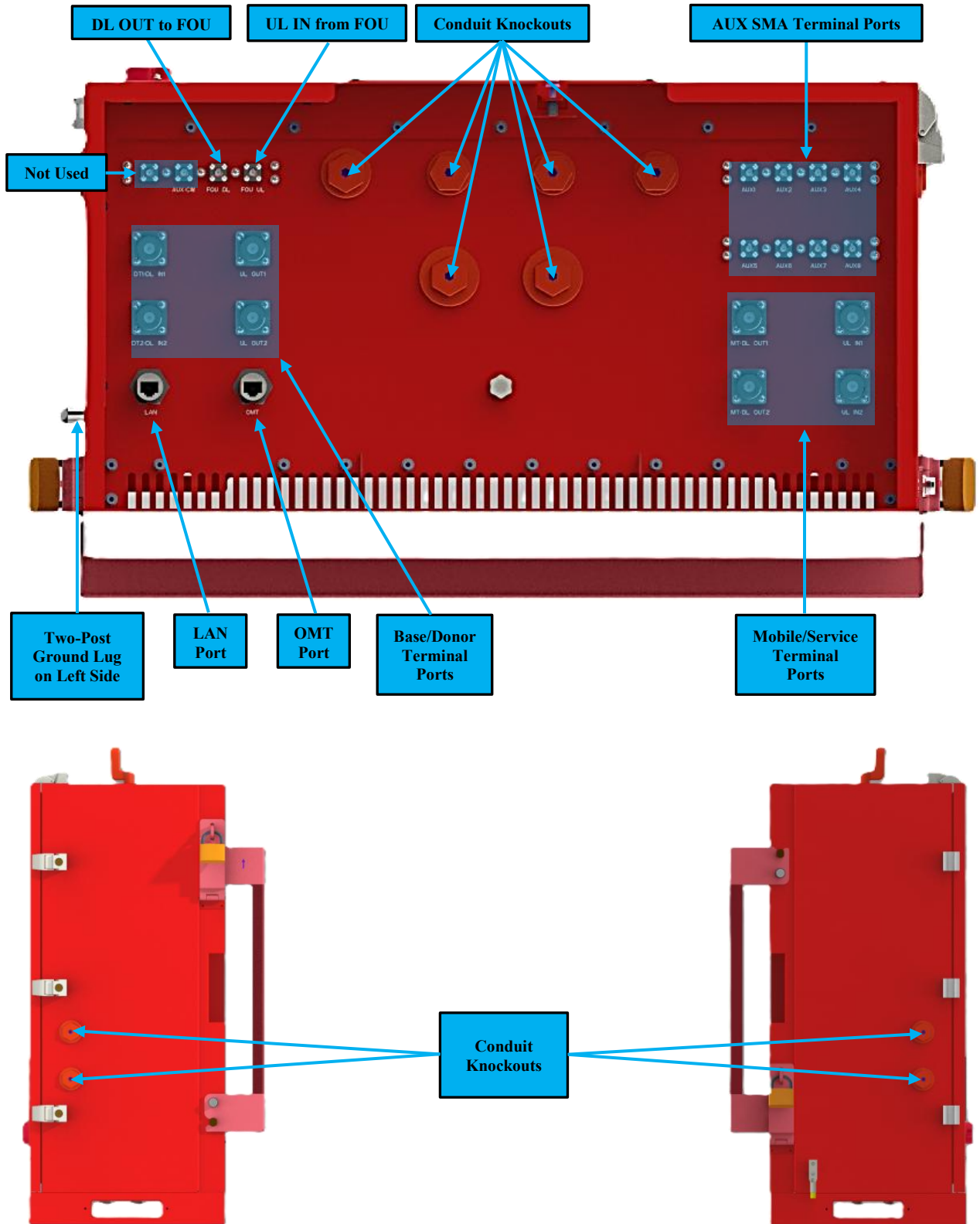

Figure 17: V3 BDA/MU Dual Band Cabinet Connections

Table 1: V3 BDA/MU Dual Band Cabinet Connections

Identifier	Descriptions
Knock Outs (Bottom)	(2) 1": For Hybrid Cable or Alarm Cables (1) 3/4": For Hybrid Cable (includes AC cable, DC Cable, and monitor cable from BBU) (3) 1/2": For Dry contact or External alarm cables
Knock Outs (Sides)	Left Side: (2) 3/4": For Hybrid Cable (includes AC cable, DC Cable, and monitor cable from BBU)  Right Side: (2) 3/4": For Hybrid Cable (includes AC cable, DC Cable, and monitor cable from BBU)
Base/Donor Terminal Ports (DT Ports)	N-Female connectors for connection to the donor antenna feedlines. The number of DT Ports will depend on the BDA configuration.  Duplexed Port Identifiers: VHF Duplexed = DT1 UHF Duplexed = DT2  Simplex Port Identifiers: VHF DL IN = DL IN1 VHF UL OUT = UL OUT1 UHF DL IN = DL IN2 UHF UL OUT = UL OUT2
Mobile/Service Terminal Ports (MT Ports)	N-Female connectors for connection to the indoor antenna feedlines. The number of DT Ports will depend on the BDA configuration.  Duplexed Port Identifiers: VHF Duplexed = MT1 UHF Duplexed = MT2  Simplex Port Identifiers: VHF DL OUT= DL OUT1 VHF UL IN= UL IN1 UHF DL OUT= DL OUT2 UHF UL IN = UL IN2
AUX SMA Terminal Ports	SMA-Female connectors reserved for future configurations.
OMT	RJ45 Connector for local WEB GUI connection.
LAN	RJ45 Connector for remote internet connection.
FOU UL/DL	SMA-Female UL IN and DL OUT ports to interface to FOU when in DAS configuration
Ground Lug	Two-Post Ground Lug for connection to protective earth ground.

Note: All Knockouts can be used with direct connection to a conduit, but liquid tight conduit fittings must be installed to maintain the UL50E Type 4 waterproof rating.

1.24 V3 BDA/MU DUAL BAND CABINET INTERNAL LAYOUT

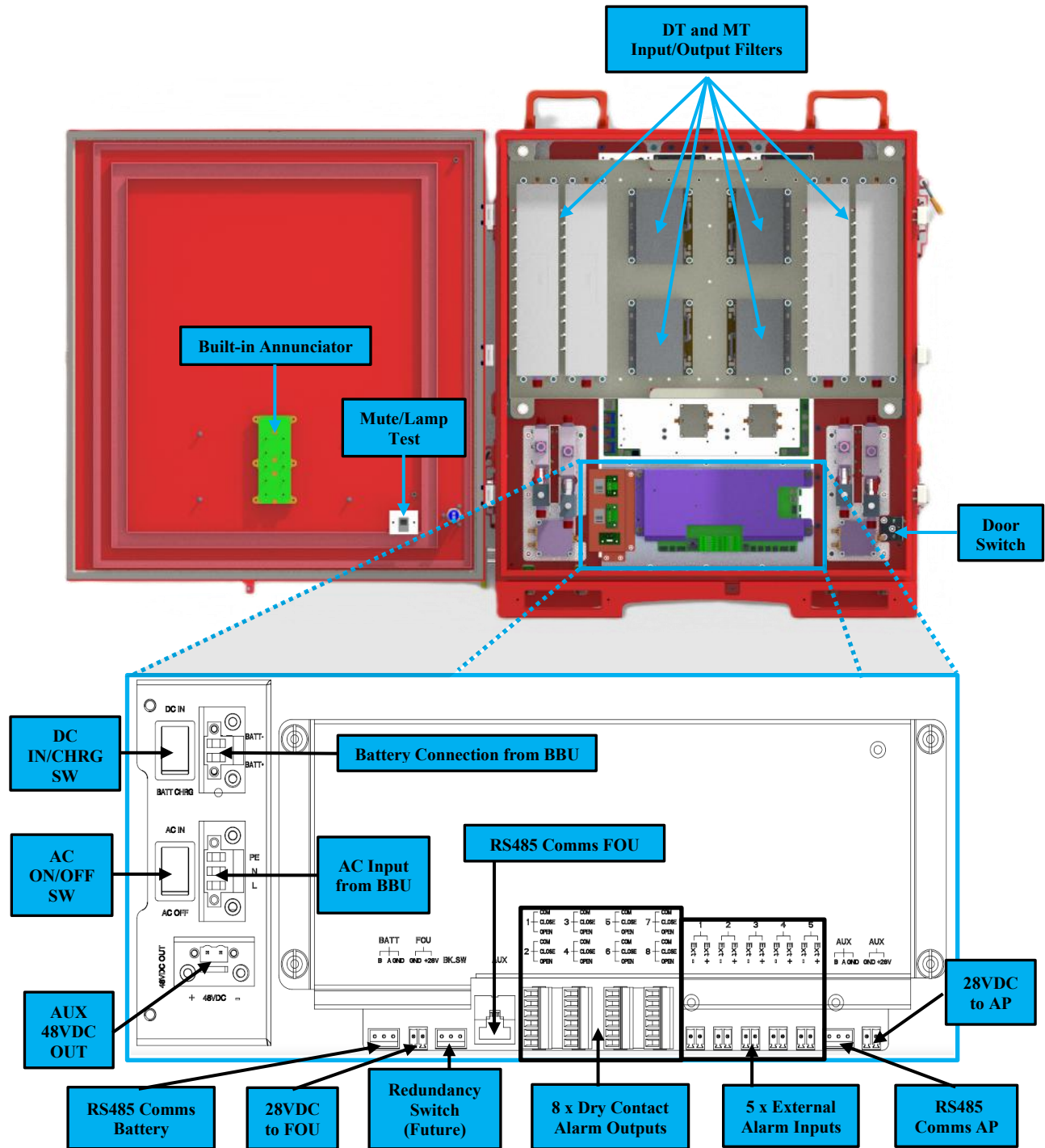

Figure 18: V3 BDA/MU Dual Band Internal Component Layout

Note: Further descriptions of these connections are provided in the installation, commissioning, and alarms sections of this manual.

1.25 V3 BDA/MU SINGLE BAND CABINET DIMENSIONS

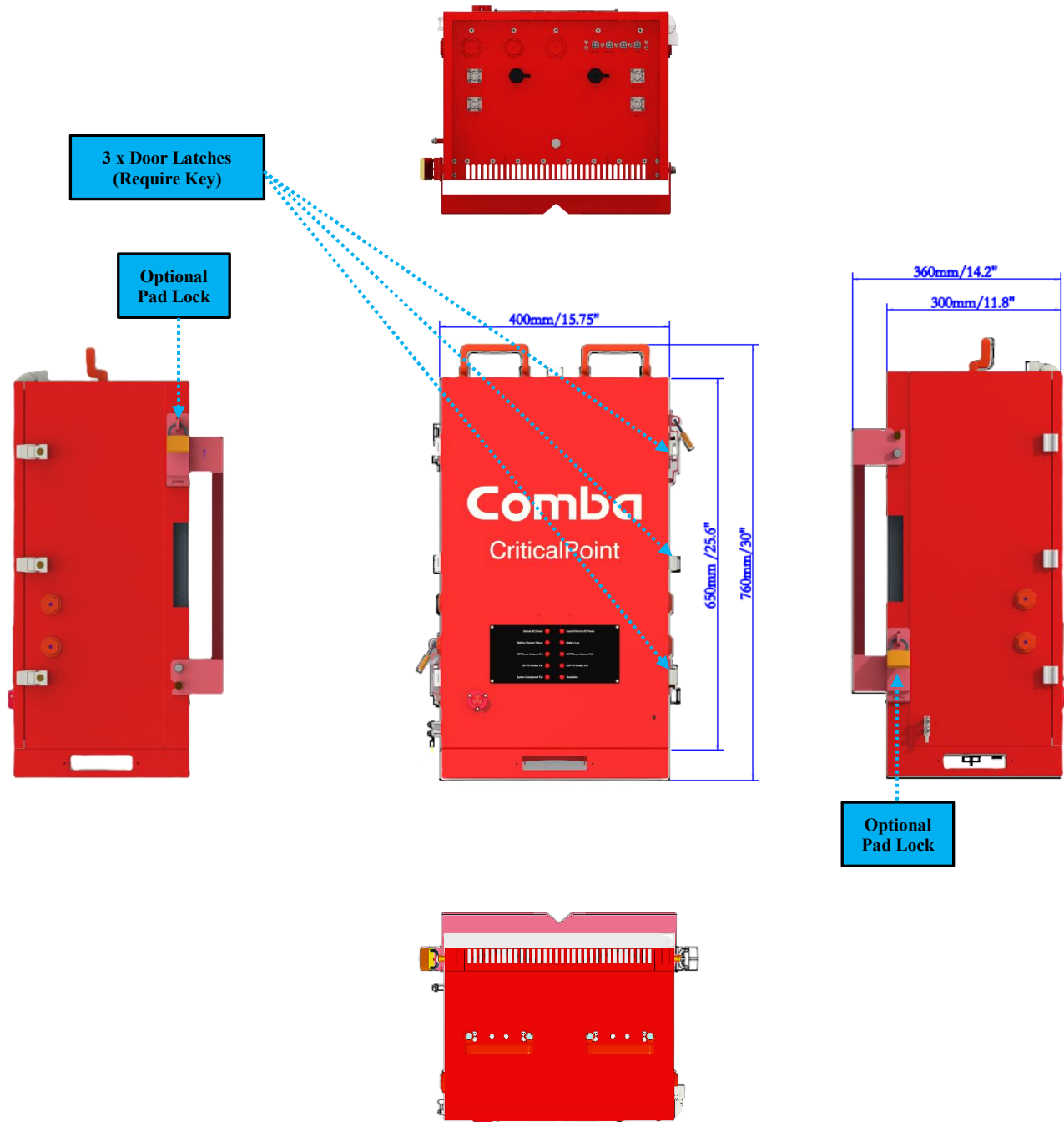

Figure 19: V3 BDA/MU Single Band Cabinet Dimensions – Front, Side, Top and Bottom View

## 1.26 V3 BDA/MU SINGLE BAND CABINET MOUNTING BRACKET DIMENSIONS

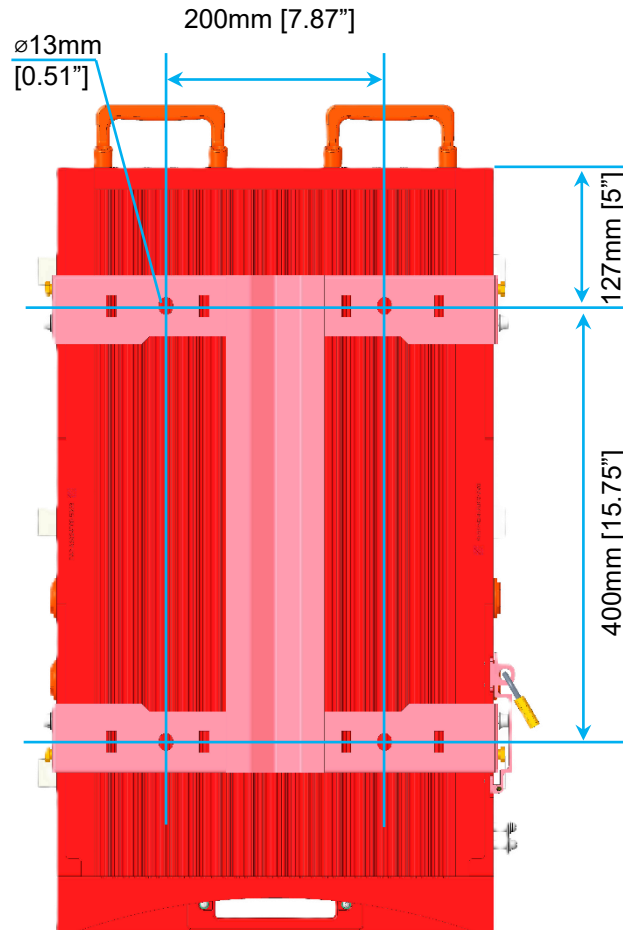

Figure 20: V3 BDA/MU/RU Single Band Cabinet Mounting Bracket Dimensions

1.27 V3 BDA/MU SINGLE BAND CABINET CONNECTIONS

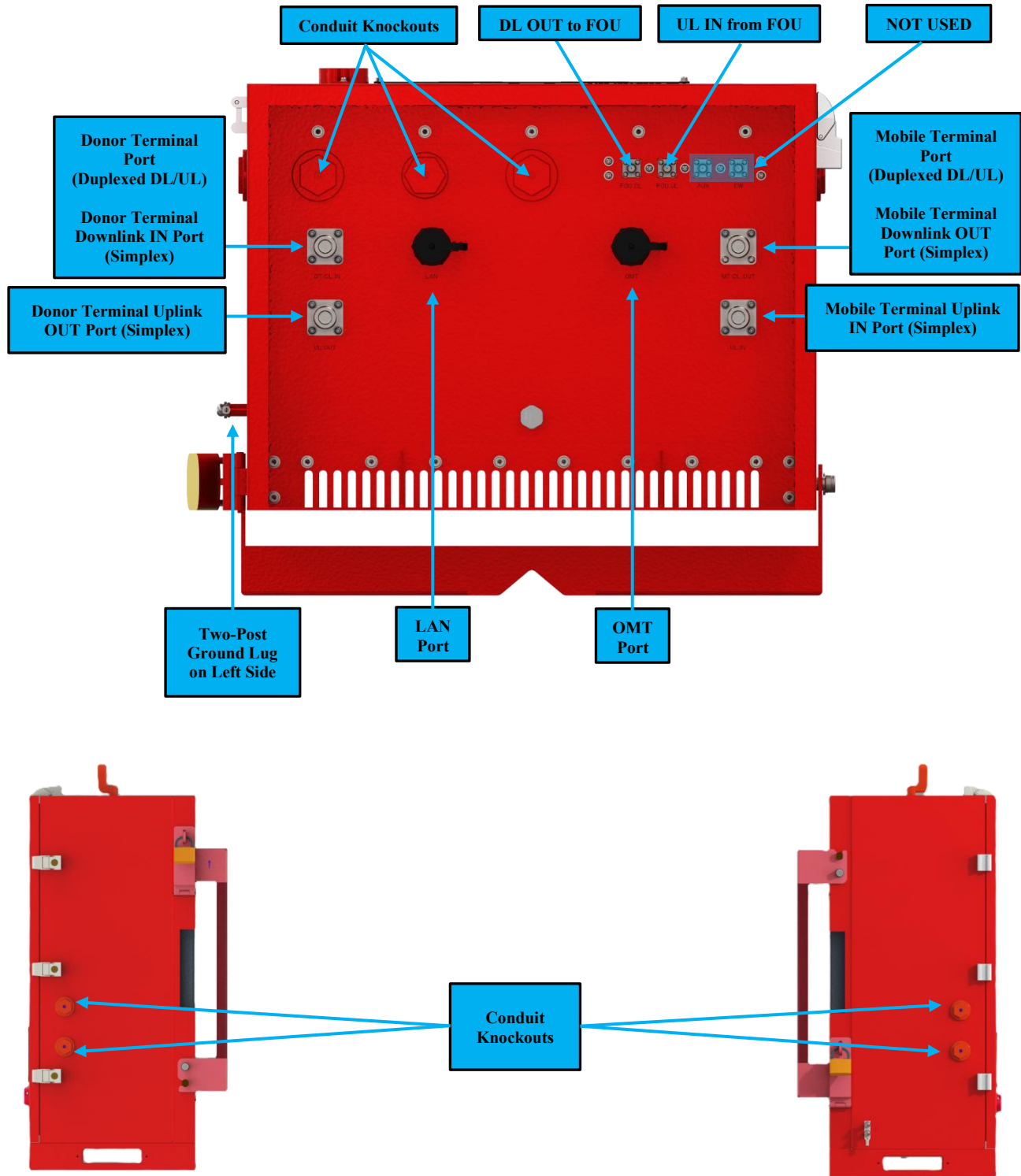

Figure 21: V3 BDA/MU Single Band Cabinet Connections

Table 2: V3 BDA/MU Single Band Cabinet Connections

Identifier	Descriptions
Knock Outs (Bottom)	(1) 1": For Hybrid Cable or Alarm Cables (1) 3/4": For Hybrid cable (includes AC cable, DC Cable, and monitor cable from BBU) (1) 1/2": For Dry contact or External alarm cables
Knock Outs (Sides)	Left Side: (2) 3/4": For Hybrid Cable (includes AC cable, DC Cable, and monitor cable from BBU)  Right Side: (2) 3/4": For Hybrid Cable (includes AC cable, DC Cable, and monitor cable from BBU)
Donor Terminal Port (DT)  Or  Donor Terminal Downlink IN Port (DL IN)	DT Port: N-Female connector for duplexed connection to the donor antenna feedline.  or  DL IN Port: N-Female connector for simplex connection to the DOWNLINK donor antenna feedline.
Donor Terminal Uplink OUT Port (UL OUT)	UL OUT Port: N-Female connector for simplex connection to the UPLINK donor antenna feedline.
Mobile Terminal Port (MT)  Or  Mobile Terminal Downlink OUT Port (DL OUT)	MT Port: N-Female connectors for connection to the indoor antenna feedline.  Or  DL OUT Port: N-Female connector for simplex connection to the DOWNLINK indoor antenna feedline.
Mobile Terminal Uplink IN Port (UL IN)	UL IN Port: N-Female connector for simplex connection to the UPLINK indoor antenna feedline.
AUX SMA Terminal Ports	SMA-Female connectors reserved for future configurations.
OMT	RJ45 Connector for local WEB GUI connection.
LAN	RJ45 Connector for remote internet connection.
FOU UL/DL	SMA-Female UL IN and DL OUT ports to interface to FOU when in DAS configuration
Ground Lug	Two-Post Ground Lug for connection to protective earth ground.

Note: All Knockouts can be used with direct connection to a conduit, but liquid tight conduit fittings must be installed to maintain the UL50E Type 4 waterproof rating.

1.28 V3 BDA/MU SINGLE BAND CABINET INTERNAL LAYOUT

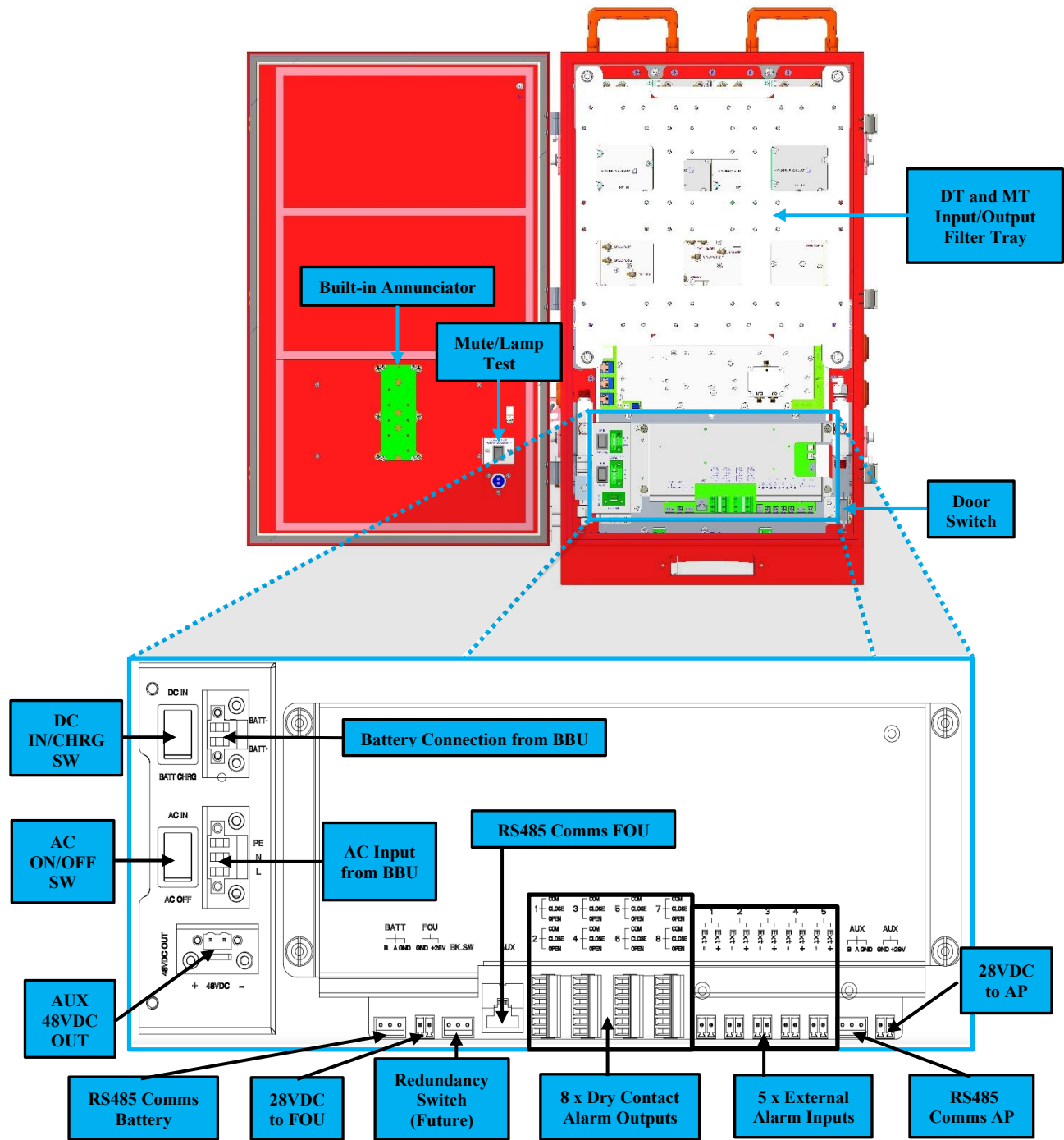

Figure 22: V3 BDA/MU Single Band Internal Component Layout

Note: Further descriptions of these connections are provided in the installation, commissioning, and alarms sections of this manual.

1.29 V3 RU CABINET DIMENSIONS

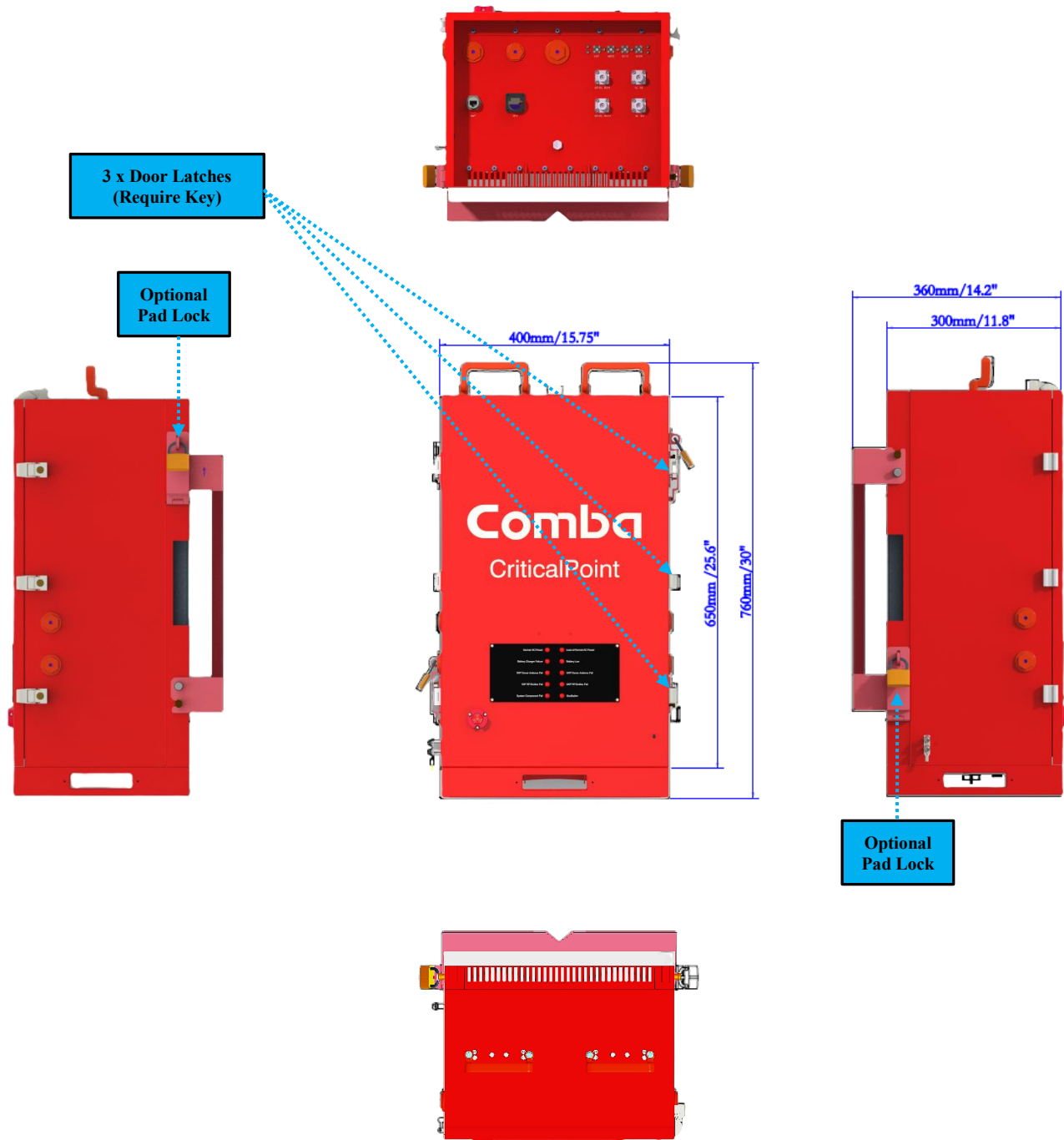

Figure 23: V3 RU – Cabinet Dimensions

### 1.30 V3 RU MOUNTING BRACKET DIMENSIONS

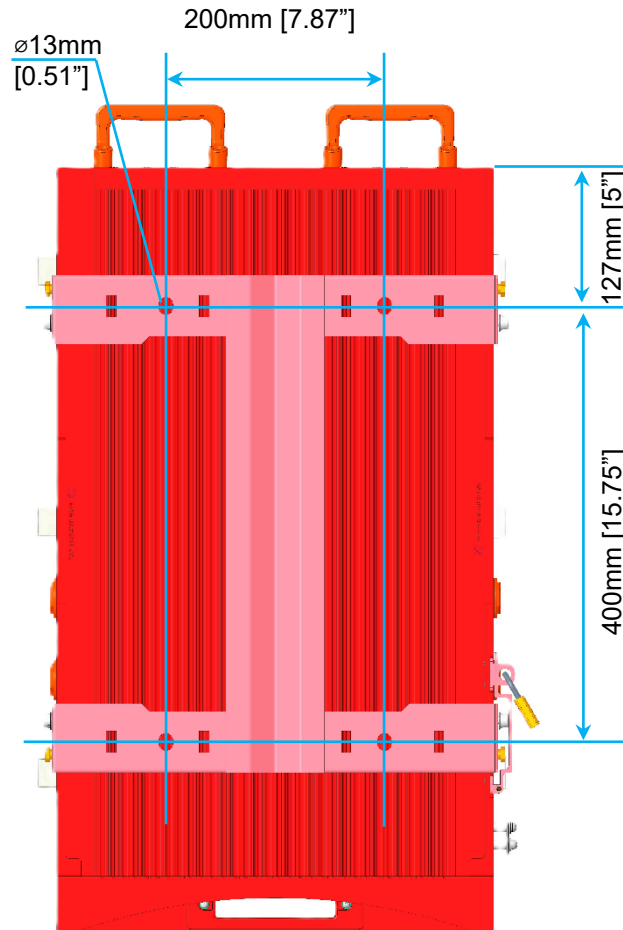

Figure 24: V3 RU Mounting Bracket Dimensions

### 1.31 V3 RU CABINET CONNECTIONS

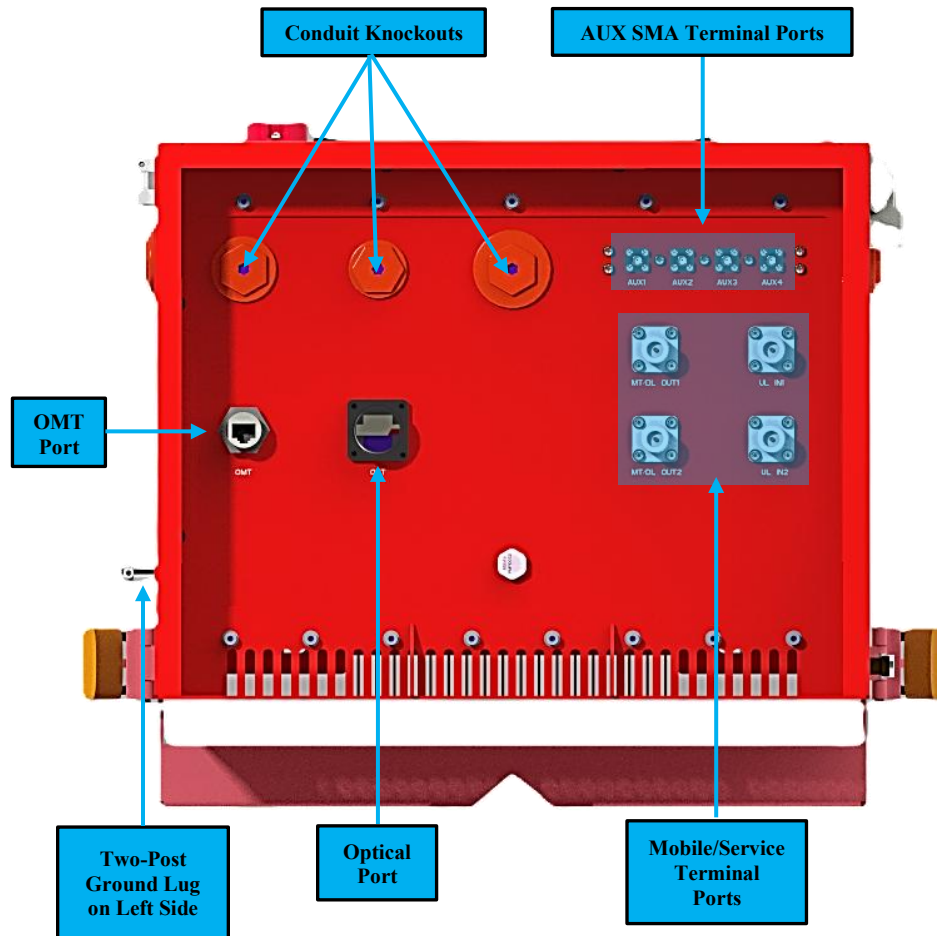

Figure 25: V3 RU Cabinet Connections

Table 3: V3 RU Cabinet Connections

Identifier	Descriptions
Knock Outs	(1) 1": For Hybrid Cable or Alarm Cables (1) 3/4": For Hybrid cable (includes AC cable, DC Cable, and monitor cable from BBU) (1) 1/2": For Dry contact or External alarm cables
Optical Port	Optical Fiber Port Connector
AUX SMA Terminal Ports	SMA-Female connectors reserved for future configurations.
MT Port	N-Female connector for connection to service antenna feedline.
OMT Port	RJ45 Connector for local WEB GUI connection.
Ground Lug	Two-Post Ground Lug for connection to protective earth ground.

Note: All Knockouts can be used with direct connection to a conduit, but liquid tight conduit fittings must be installed to maintain the UL50E Type 4 waterproof rating.

1.32 V3 RU INTERNAL LAYOUT

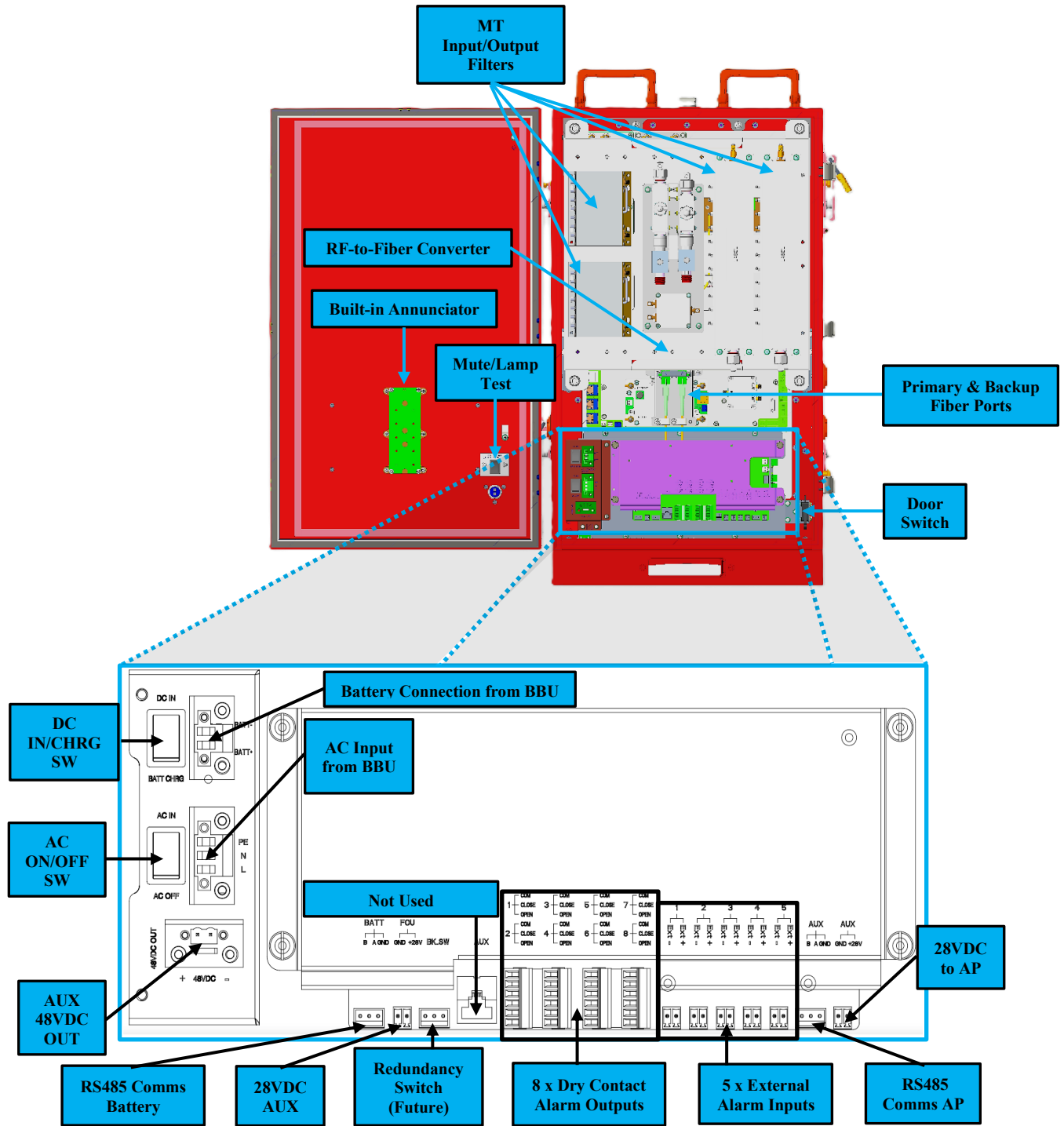

Figure 26: V3 RU Internal Component Layout

Note: Further descriptions of these connections are provided in the installation, commissioning, and alarms sections of this manual.

1.33 V3 BBU CABINET DIMENSIONS

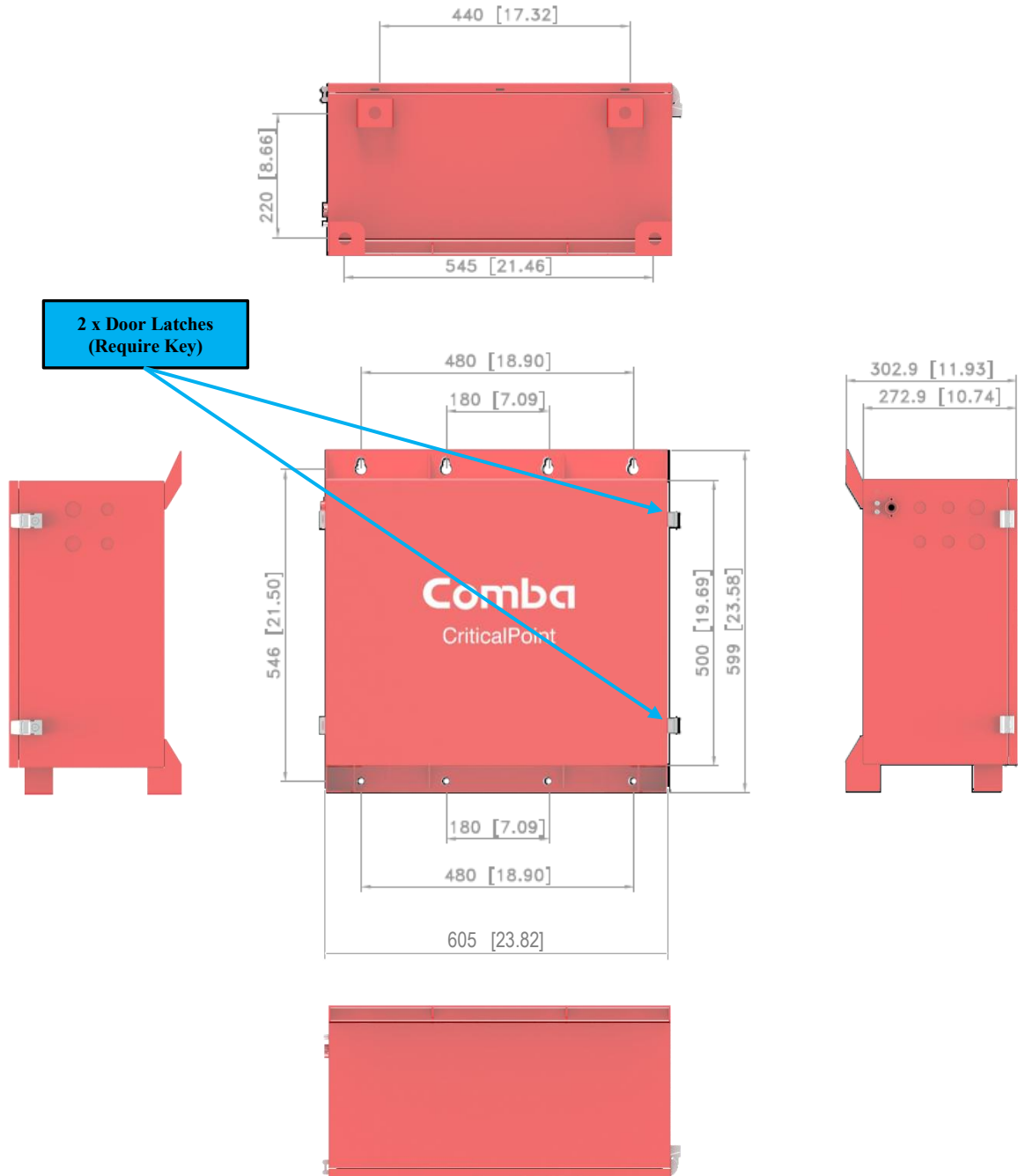

Figure 27: V3 BBU Cabinet Dimensions – Front, Side and Bottom View

### 1.34 V3 BBU CABINET CONNECTIONS

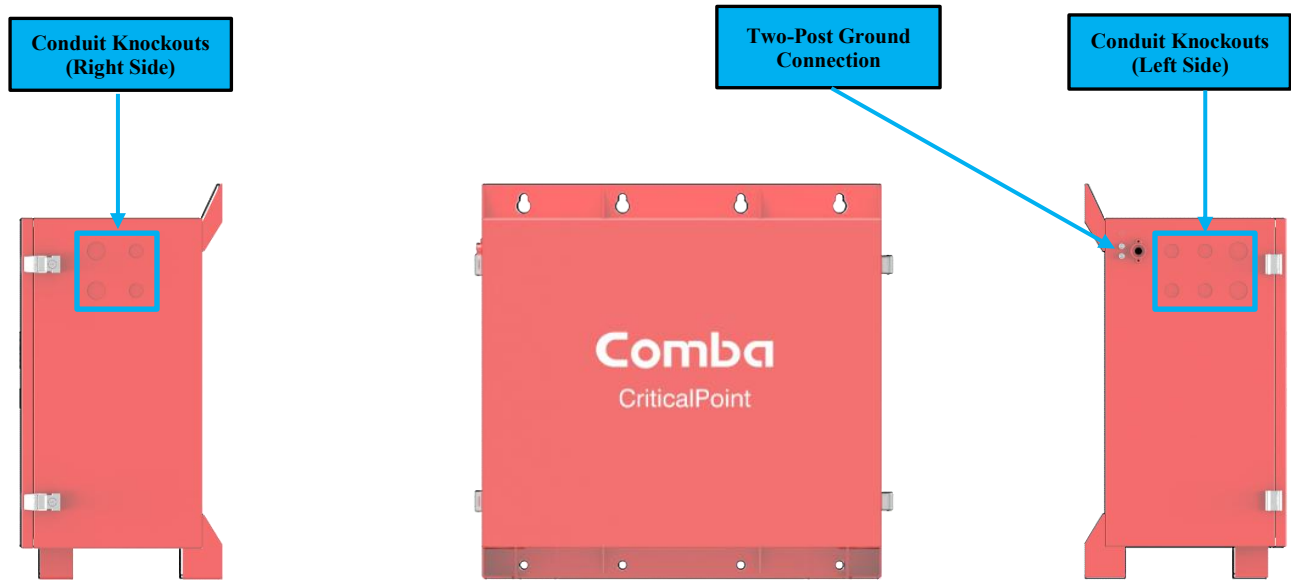

Figure 28: V3 BBU Cabinet Connections

Table 4: V3 BBU Cabinet Connections

Identifier	Descriptions
Knock Outs (Left Side)	(2) 3/4": For Hybrid cable (includes AC cable, DC Cable, and monitor cable from BBU) (4) 1/2": For AC or DC Power Connections
Knock Outs (Right Side)	(2) 3/4": For Hybrid cable (includes AC cable, DC Cable, and monitor cable from BBU) (2) 1/2": For AC or DC Power Connections
Ground Connection	Two-Post Ground for connection to protective earth ground.

Note: All Knockouts can be used with direct connection to conduit, but liquid tight conduit fittings must be installed to maintain the UL50E Type 4 waterproof rating.

1.35 V3 BBU INTERNAL LAYOUT

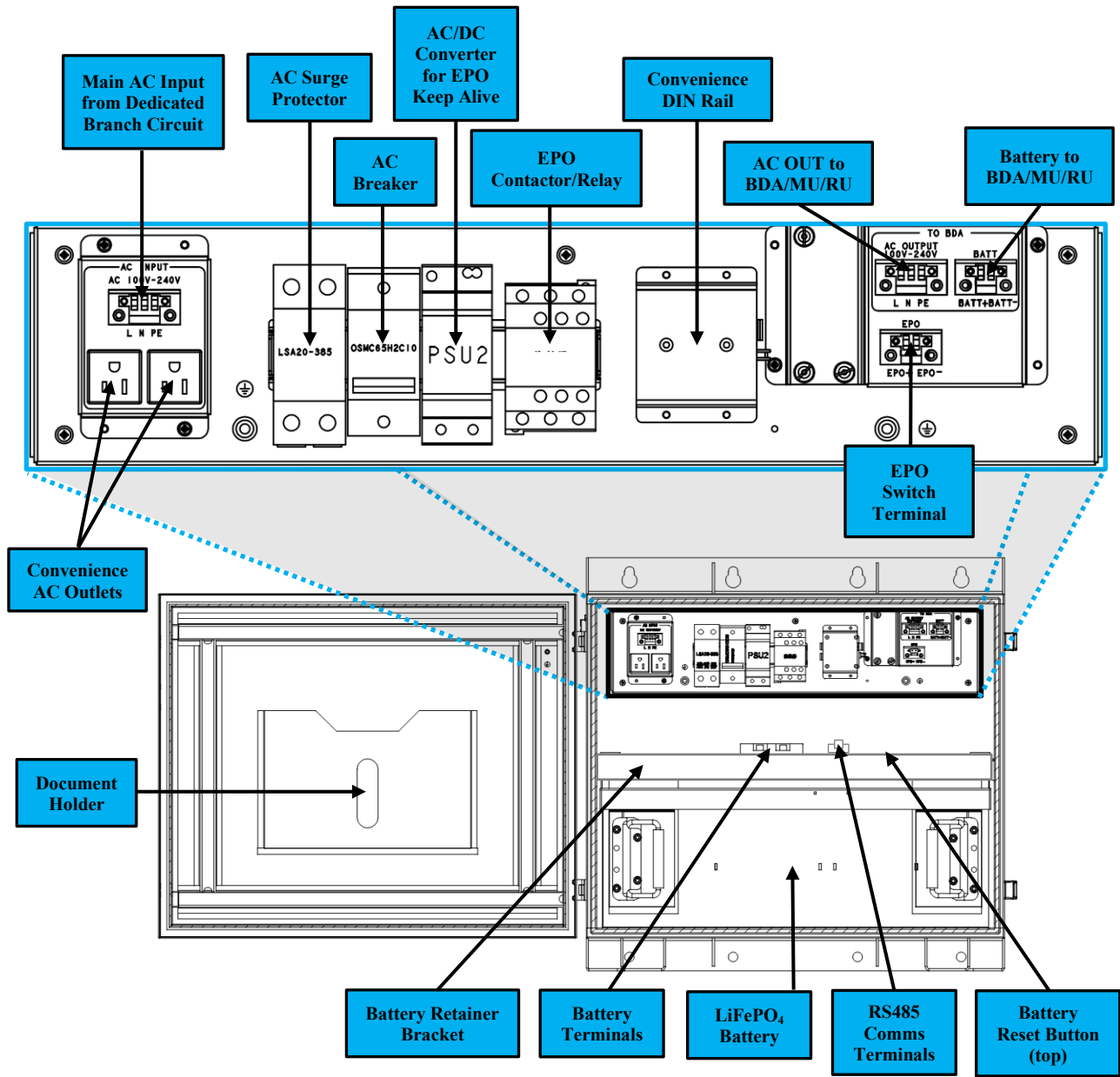

Figure 29: V3 BBU Internal Component Layout

Note: Further descriptions of these connections are provided in the installation, commissioning, and alarms sections of this manual.

1.36 V2 FOU CABINET DIMENSIONS

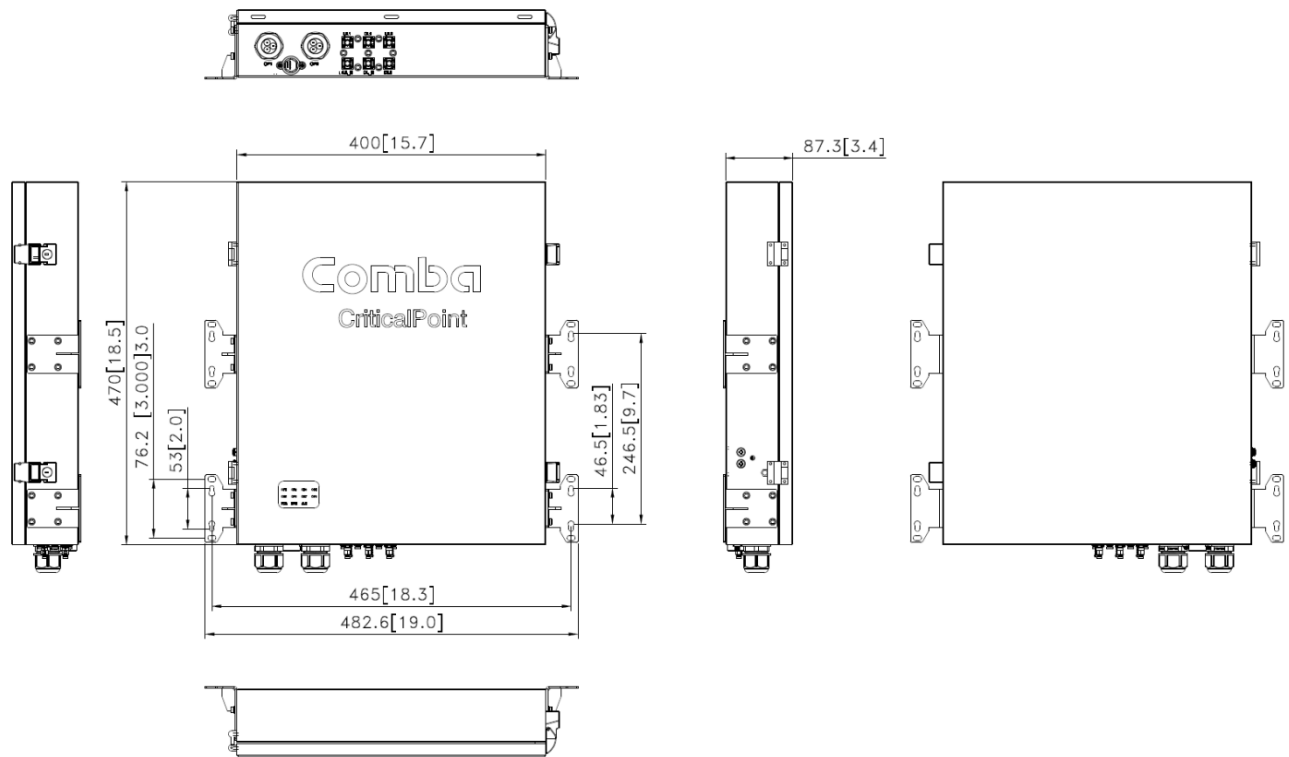

Figure 30: V2 FOU Cabinet Dimensions - Front, Side and Bottom View

1.37 V2 FOU CABINET CONNECTIONS

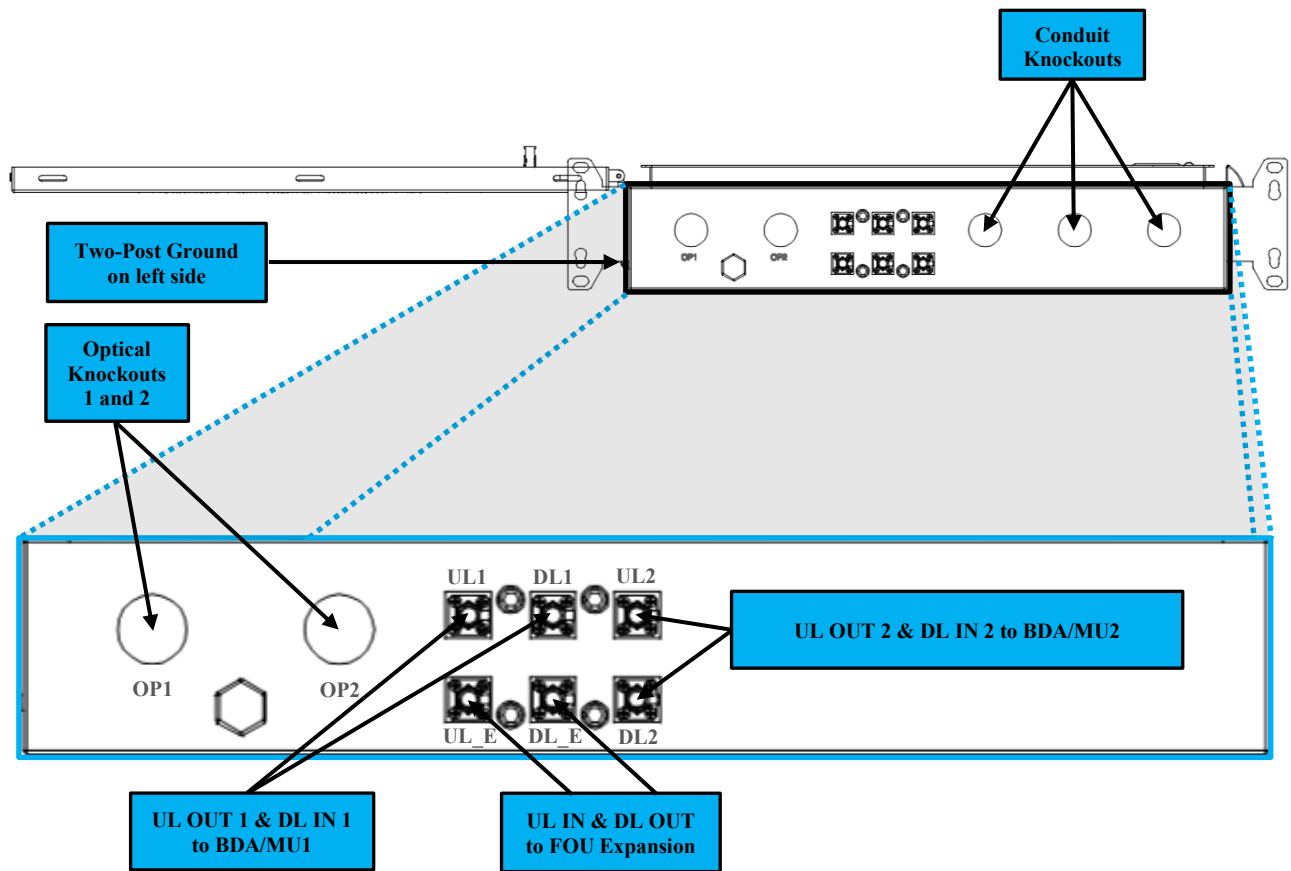

Figure 31: V2 FOU Cabinet Connections

Table 5: V2 FOU Cabinet Connections

Identifier	Descriptions
Knock Outs	(3) 1/2": For DC Power, Cat5/RJ45 cable for RS485 Comms, and/or alternate fiber ports
Optical Knock Outs	Optical Knock Out 1: Comes from factory with fiber cable gland installed. Used for fibers 1-4. Optical Knock Out 2: Additional knock Out for fibers 5-8
UL 1/DL 1	SMA-Female connectors to interface to BDA/MU 1
UL 2/DL 2	SMA-Female connectors to interface to BDA/MU 2 (Redundancy Feature not currently available)
UL E/DL E	SMA-Female connectors to interface to additional FOUs for system expansion
Ground Connection	Two-Post Ground for connection to protective earth ground.

Note: All Knockouts can be used with direct connection to conduit, but liquid tight conduit fittings must be installed to maintain the UL50E Type 4 waterproof rating.

1.38 V2 FOU INTERNAL LAYOUT

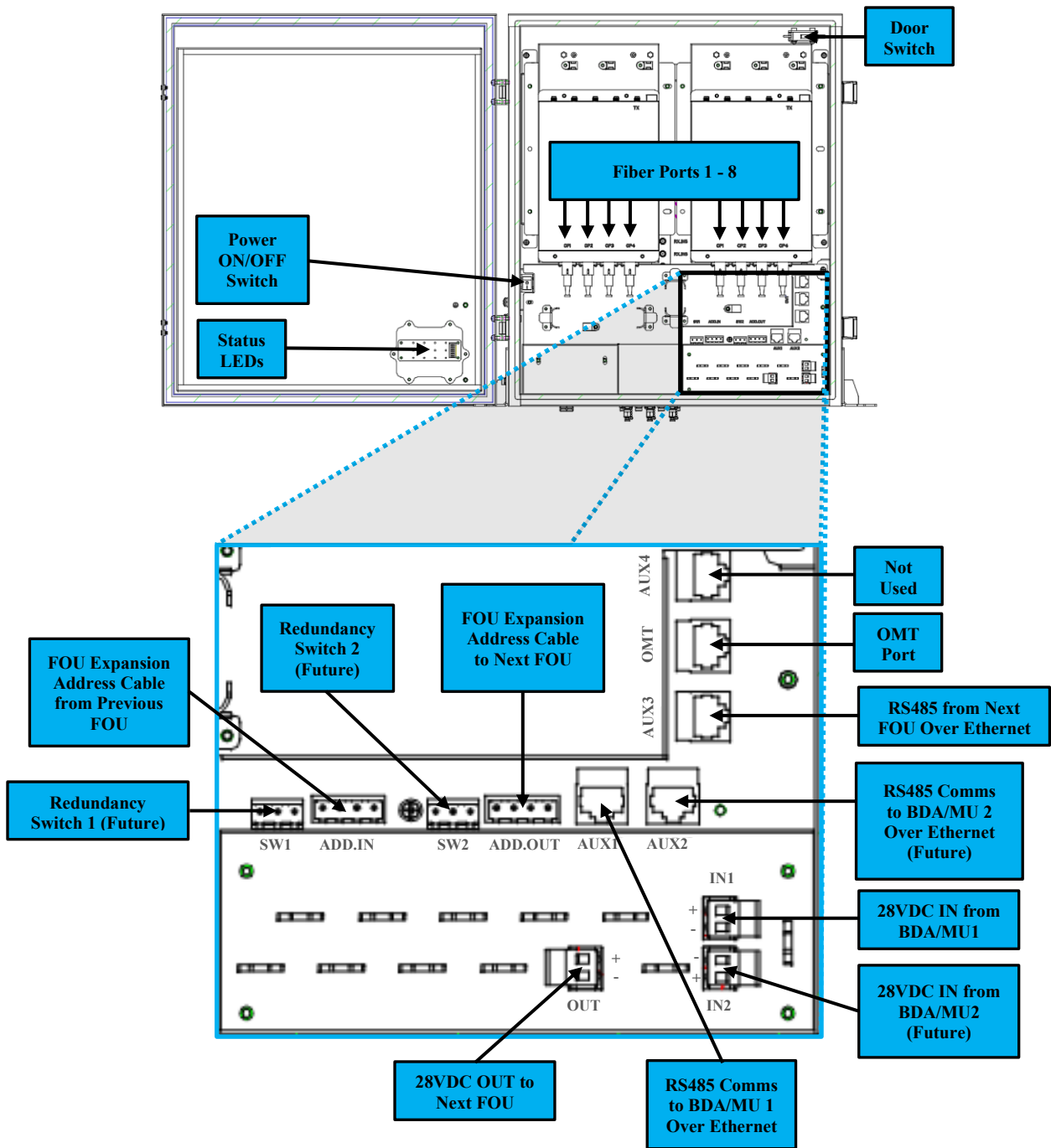

Figure 32: V2 FOU Internal Layout

Note: Further descriptions of these connections are provided in the installation, commissioning, and alarms sections of this manual.

## 1.39 EQUIPMENT CONSTITUTION

The typical PS BDA/MU and Fiber DAS consists of the following core components:

**Master Digital Board and Slave Digital Board:** The MCU is used to monitor and control the operation of the BDA/MU/RU/FOU. It also provides the communication interface for remote control and status indication. LED indicators provide the operation status of the MCU.

**Duplexer:** The duplexer or triplexer is located near the MT and DT terminals and permits the uplink and downlink signals to share a common antenna line while also rejecting non-desired out-of-band signals.

**VHF/UHF Digital Integrated Module and Power Amplifier:** Consists of the Power Conversion module, RF module, digital process module and monitoring modules. The Power Conversion module converts +28V DC voltage into +9VJK and +9VRF. +9VJK, +9VRF are supplied to the monitoring unit, and the RF unit in the integrated module separately. The RF module amplifies and converts the RF signal to IF signal. The Digital process module converts the IF signal into baseband signal via AD conversion and extraction, and filtering. After that, the IF signal will be amplified and converted to an RF signal by the RF module for RF filtering and amplification. The Monitoring module monitors and controls the system parameters and is the interface for both remote monitoring and local commissioning.

**Power Supply Unit (PSU)/Charger:** The PSU/Charger converts the input voltage into a stable DC supply to provide power for the internal functional modules as well as charging the batteries.

**Power/Charging Switch Panel:** The PSU/Charger switch panel is in the BDA/MU and RU devices and contains the main AC and Battery Charging switches to control turning the device ON or OFF.

**Power ON/OFF Switch:** The Power ON/OFF switch is located inside the FOU and AP devices. It is a standalone switch used to control turning the device ON or OFF.

**Mute/Lamp Test Switch:** The Mute/Lamp Test switch is used for two functions. The user can push the button briefly to silence any current alarms. Additionally, the button can be held for a period longer than 5 seconds to test the alarm annunciator LEDs and the alarm buzzer.

**Door Switch:** Most devices contain a door switch which is used to generate an alarm when the door is open.

**Power and Communications Distribution Board:** The Power and Comms Distribution Board is inside the FOU and consists of the power distribution and communication distribution components. These components are used to extend power and communications from the BDA/MU to the main FOU and additional expansion FOUs.

**Fiber-Optic Modules:** The Fiber-optic modules are inside the FOU, and the RUs and they are used to convert RF signals to Optical signals and vice-versa to extend the signals over a long distance of fiber with minimal losses.

**Annunciator and Status LED Modules:** The annunciator and status LED modules are simple LED boards which interface to the main digital board and will illuminate under certain alarm conditions.

**Passive Components for RF Distribution:** Passive components like couplers, splitters, and coax cables can be found in most components and they are used to distribute the signals internally to different RF components in the device.

End of Section

## 2 INSTALLATION

### 2.1 WARNINGS, ALERTS AND CAUTIONS



Electric Hazard

#### Safety to personnel

Before installing, modifying, or replacing any of the equipment, the user manual should be read and understood in its entirety. The user needs to supply the appropriate AC or DC power to the equipment. Incorrect power connections can damage the equipment and may cause injury to the user.



HOT SURFACE

Be aware that in certain conditions the devices can become very warm and can cause minor injuries if handled without the appropriate Personal Protective Equipment (PPE) such as gloves.



Non-ionizing Radiation Hazard

#### Radio Frequency Energies

There may be situations, particularly for workplace environments near high-powered RF sources, where recommended limits for safe exposure of human beings to RF energy could be exceeded. In such cases, restrictive measures or actions may be necessary to ensure the safe use of RF energy.



High Voltage

#### High Voltage

The equipment has been designed and constructed to prevent, as far as reasonably practicable danger. Any work activity on or near equipment involving installation, operation or maintenance must be, as far as reasonable, free from danger. Where there is a risk of damage to electrical systems involving adverse weather, extreme temperatures, wet, corrosive, or dirty conditions, flammable or explosive atmospheres, the system must be suitably installed to prevent danger.



Electric Hazard

#### Protective Earthing

Equipment provided for the purpose of protecting individuals from electrical risk must be suitable for the purpose and properly maintained and used.



General Warning

#### Handling Precautions

This covers a range of activities including lifting, lowering, pushing, pulling, carrying, moving, holding, or restraining an object, animal, or person from the equipment. It also covers activities that require the use of force or effort, such as pulling a lever, or operating power tools. Where some of the above-mentioned activities are required, the equipment must be handled with care to avoid being damaged.



General Warning

#### Electrostatic Discharge (ESD)

Observe standard precautions for handling ESD-sensitive devices. Assume that all solid-state electronic devices are ESD-sensitive. Ensure the use of a grounded wrist strap or equivalent while working with ESD-sensitive devices. Transport, store, and handle ESD-sensitive devices in static-safe environments.

## 2.2 SITE PLANNING CONSIDERATIONS



### Site Considerations

Outdoor equipment is designed to be waterproof, rainproof, and with snow protection. Temporary protection should be taken when the equipment enclosure is opened for installation or maintenance in an outdoor environment. The equipment must not be opened for installation or maintenance in harsh weather (e.g. gale, storm rainfall, extreme temperatures, and high humidity).



### Installation Location

The mounting surface shall be capable of supporting the weight of the equipment. To avoid electromagnetic interference, a proper mounting location must be selected to minimize interference from electromagnetic sources such as large electrical equipment.



### Environmental

Humidity has an adverse effect on the reliability of the equipment. It is recommended to install the equipment in locations having stable temperatures and unrestricted airflow. The installation location for the product should be well ventilated. The equipment has been designed to operate at the temperature range and humidity level as stated in the product specifications in the datasheet. Direct sunlight exposure to the equipment should be avoided. Provide additional shelter if necessary.



### Power Supply

The power supply unit (PSU) provides power to all modules within the equipment. It is recommended that the PSU be operated on a dedicated circuit breaker or fused circuit.



### Grounding Requirement

Verify that the equipment has been well grounded. This includes antennas and all cables connected to the system. Ensure lightning protection for the antennas is properly grounded.



### Cable Routing

Depending on equipment configuration, a variety of types of cables are required. Where applicable, ensure cables are properly routed and secured so that they are not damaged.



### Manual Handling

During transportation and installation, take necessary handling precautions to avoid potential physical injury to the installation personnel and the equipment.

## 2.3 INSTALLATION CHECKLIST

- Working space available for installation and maintenance for each mounting arrangement. Ensure unrestricted airflow.
- Ensure earth ground point is within reach of the ground wire.
- Ensure a power source is within reach of the device and the power source has sufficient capacity.
- Do not locate the equipment near large transformers or motors that may cause electromagnetic interference.
- Where appropriate, ensure unused RF connectors on devices are terminated before powering up.
- Verify all passive devices including coaxial cables, optical cables, connectors, splitters, couplers, tappers, surge arrestors, and antennas have been installed properly and are performing as expected.
- Reduce signal loss in feeder cable by minimizing the length and number of RF connections.
- Ensure VSWR of antennas system  $< 1.5:1$ .
- Ensure equipment will be operated within the stated environment (see datasheet)
- Observe handling of all cables to prevent damage.
- The donor antenna should have a narrow beamwidth and be positioned in a line-of-sight (LOS) path to the donor BTS site so that the donor signal level is maximized. This allows the use of minimum gain to achieve the maximum DL output power. The UL gain is typically set lower than or equal to the DL gain to minimize noise interference to the donor BTS.
- Service antennas should be selected based on the type of service area, e.g., indoor antenna for indoor application, and panel antenna for outdoor application.
- Ensure the required tools are on hand to perform the installation work.

## 2.4 GOODS INWARD INSPECTION

- Verify the number of packages received against the packing list.
- Check all packages for external damage; report any external damage to the shipping courier. If there is damage, a shipping agent should be present before unpacking and inspecting the contents because damage during transit is the responsibility of the agent.
- Open and check each package against the device packing list. If any items are missing, contact Comba.
- Do not remove items from anti-static packing until it is ready for installation. If damage is discovered at the time of installation, contact the shipping agent.

**See Appendix C for an example device packing list.**

## 2.5 TOOLS

**See Appendix A for a full list of the recommended tools required for installation and routine maintenance.**

## 2.6 EQUIPMENT GROUNDING

The Ground Connection should be the first wire connection made to any device after it has been successfully mounted and secured. Please ensure all equipment is grounded before moving forward with making any AC, DC, or RS485 connections.

The cabinets must be grounded securely by connecting a copper wire (CSA 16mm<sup>2</sup>) to the grounding terminal connection of the equipment, and the other end to a protective ground (i.e., building earth point). An internationally acceptable color code of the ground connection wire is green/yellow.

Such a ground connection implements the “Protective Ground Connection” and must be connected to the equipment at the designated ground point. In general, do not connect the supply before establishing an adequate ground (earth) connection.

Construct the ground wire and use appropriate crimp connectors where necessary. Locate and connect the equipment grounding terminal to a protective ground (i.e., building earth point).

Note: Follow your local codes.

## 2.7 V3 BDA/MU/RU MOUNTING BRACKET PREPARATION

- The BDA/MU/RU devices arrive from the factory with the wall mounting bracket attached to the cabinet. Prior to installation, remove the mounting bracket from the cabinet by removing the M8x20 bolts.

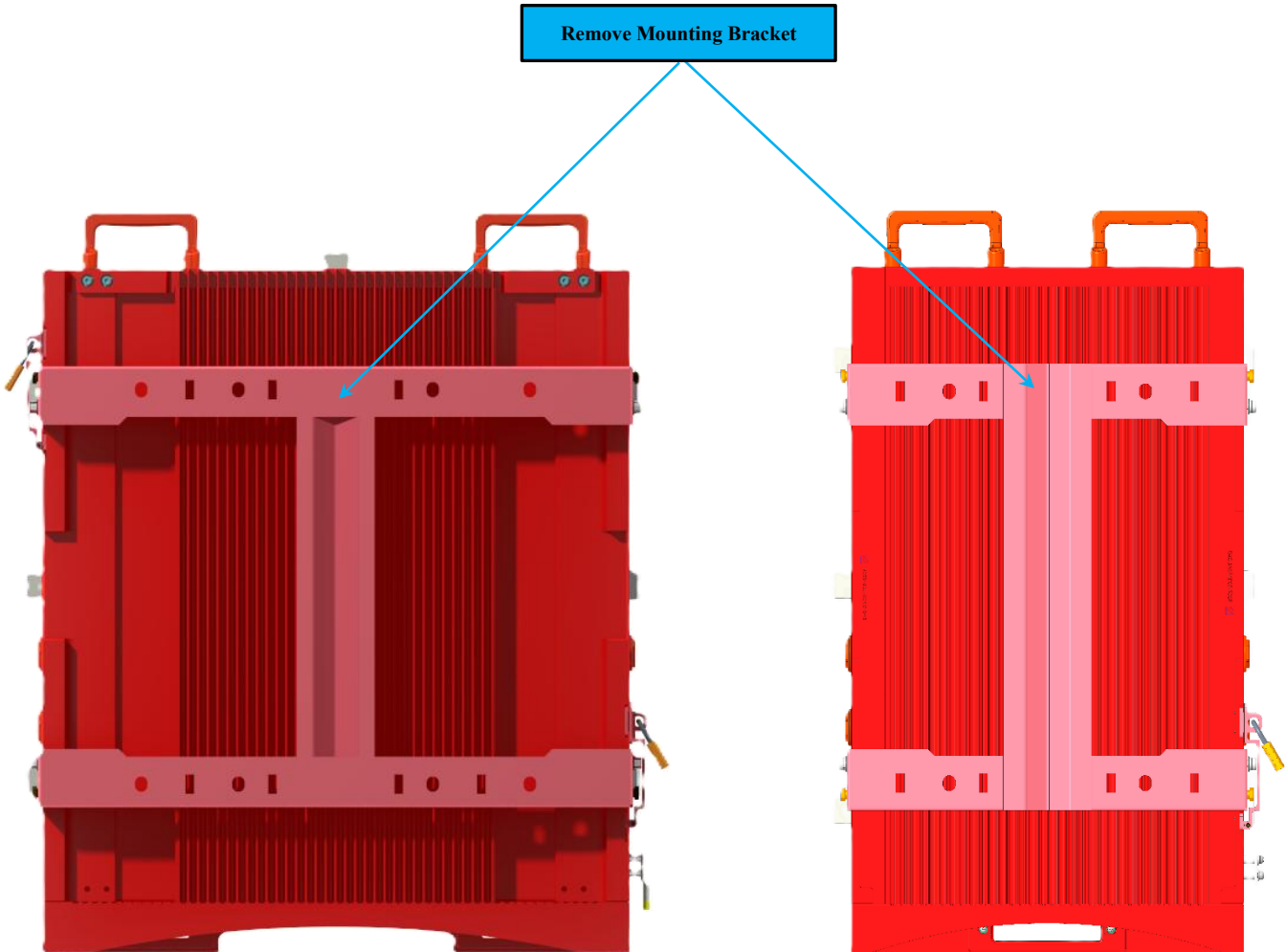

Figure 33: V3 BDA/MU/RU Mounting Bracket Overview

## 2.8 V3 BDA/MU/RU WALL MOUNTING

- Drill four holes on the wall/plywood using the position of four holes on the mounting bracket as a guide.
- Install the mounting bracket on the wall. It is recommended to use 3/8" x 1-1/2" lag screws and fender washers when mounting to 3/4" fire treated plywood. If mounting to a concrete wall, DIN Rails, or any other materials, refer to the local building code. Secure the mounting bracket.
- Hang the cabinet on the mounting bracket by using the top two cabinet hanger pegs. Lift the cabinet into position, align the pegs with the hanging points, and gently drop onto the hanging points. Ensure the device is secure before letting go. It is recommended to have a second person assisting/observing the hanger pegs position to help guide the installer. Secure the enclosure to the bracket with the 4 x M8 bolts which are provided with the unit.

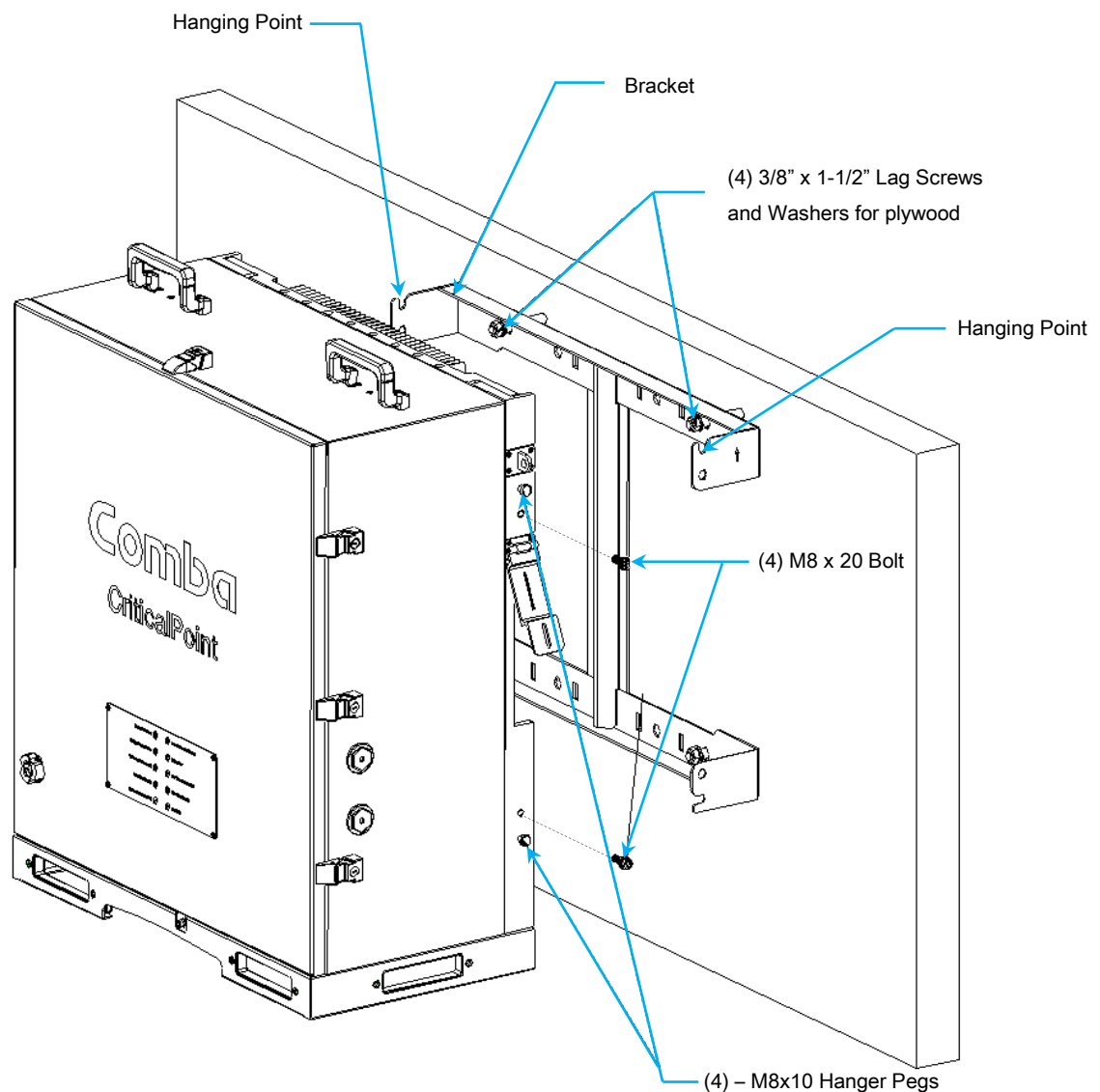

Figure 34: V3 BDA/MU/RU Wall Mounting

## 2.9 V3 BDA/MU/RU SYSTEM WIRING - AC POWER ONLY (NO BBU)

In some rare cases the V3 BDA will be fed directly from a 120VAC circuit without utilizing any type of battery backup system. For those cases, the main AC Cable provided by the installer can be fed directly into the BDA through a knockout and connected to the AC Input. See below for wiring instructions.

- Switch both AC IN/AC OFF (POWER) and DC IN/BATT CHRG (BATTERY) to OFF (O) in the BDA/MU/RU
- Ensure the AC Cable you are connecting is not live/hot. Make sure the Main AC Breaker is turned OFF at the electrical box.
- Connect AC Wires to the Phoenix connector inside the BDA/MU/RU. The Phoenix connector is removable for ease of installation.
  - a. Connect (AC) Black Wire to L
  - b. Connect (AC) White Wire to N
  - c. Connect (AC) Green/Yellow Wire to PE (GND)

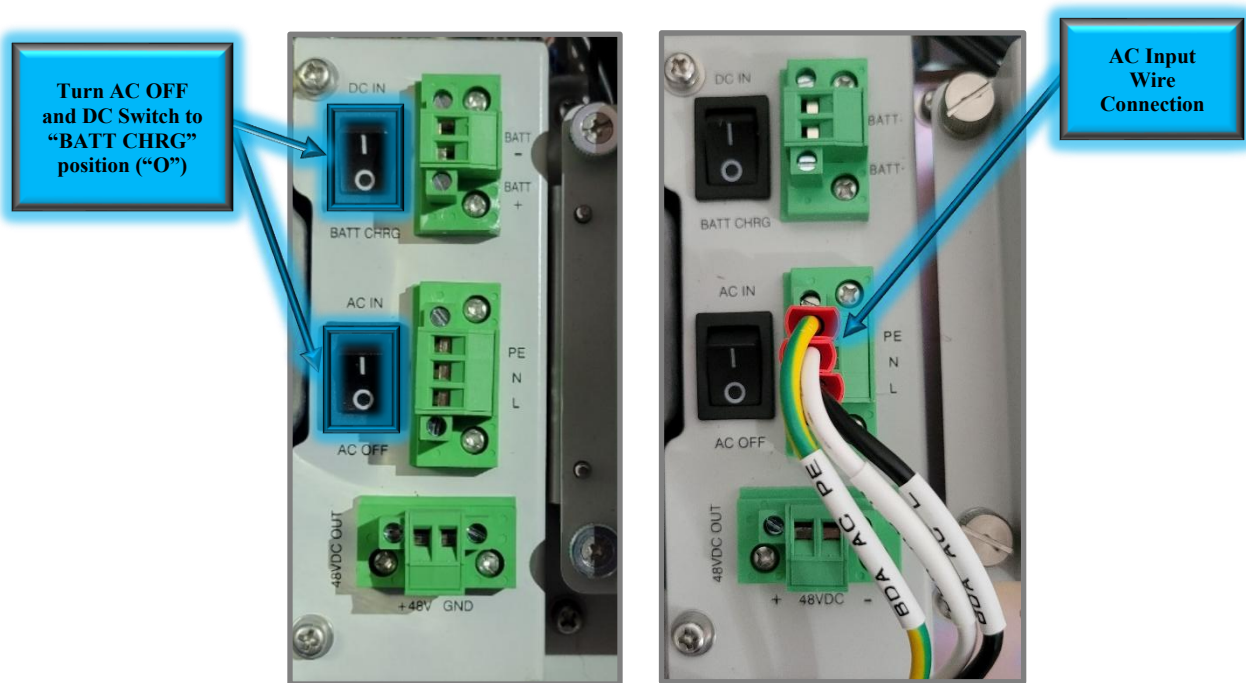

Figure 35: V3 BDA/MU/RU AC Power OFF Switch and Direct AC Power Connection without BBU



**Caution:** You must follow your local code requirements for guidance on AC Cable installation. See Section 2.13 for additional guidance on installing cables inside of conduit as well as free wiring cables. Please ensure the correct liquid tight connector or cable gland is used accordingly.

- Power up the system by turning on the AC IN Switch

When the application only calls for 120VAC Power to be fed to the device without any battery backup, the user must login to the device GUI, navigate to the Internal Charger Status/BBU page, and modify the Battery Backup Unit setting to change from “Internal” to “3<sup>rd</sup> party” as shown in Figure 36 below. Otherwise, the BDA/MU/RU will expect to see communication from a Comba V3 BBU and will generate false alarms.

- Login to the device GUI, navigate to the <Device – Overview – Internal Charger Status/BBU – Battery Backup Unit – Modify>
- Change the Battery Backup Setting from “Internal” to “3<sup>rd</sup> party”

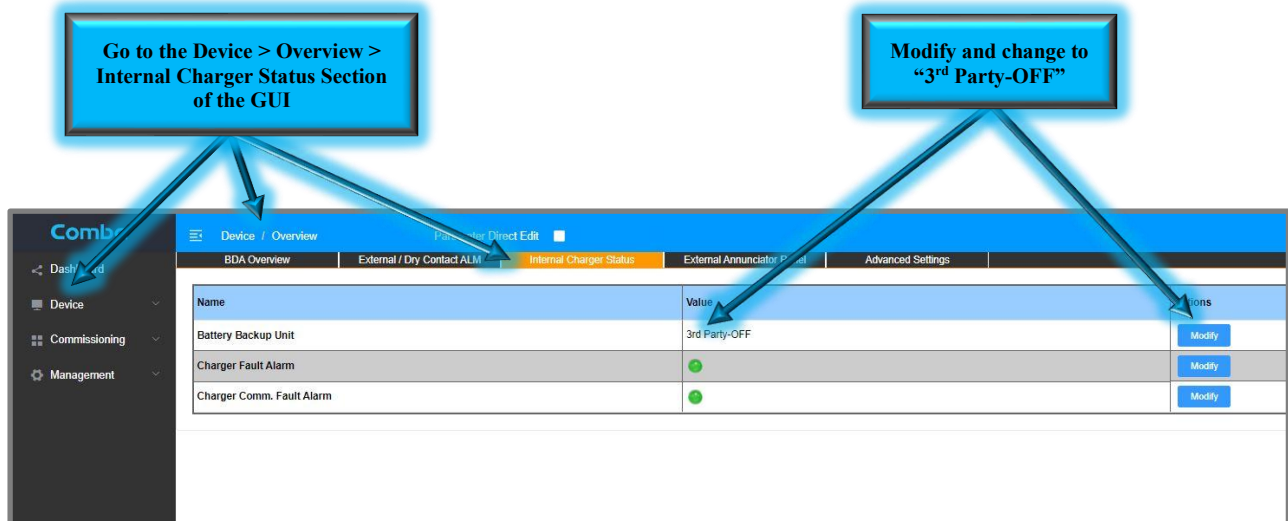

Figure 36: Disabling BBU in the BDA/MU/RU GUI for AC Only Application

## 2.10 V3 BDA/MU/RU SYSTEM WIRING - DC POWER ONLY

In some cases, the V3 BDA/MU/RU will be fed directly from a Comba V1/V2 BBU or a third party supplied 48VDC power source such as a third party BBU or AC/DC converter. For those cases, the 48VDC Cable provided by the installer can be fed directly into the BDA/MU/RU through a knockout and connected to the DC/Battery Input. See below for wiring instructions.



**Alert! The DC/Battery Negative terminal “BATT - ” inside the BDA/MU/RU is tied to the ground! Use only for +48VDC or floating DC input devices. No -48VDC connections are allowed! It is recommended to measure the power source before connecting it to Comba equipment.**

- Switch AC IN/AC OFF (POWER) to OFF (O) in the BDA/MU/RU.
- Switch DC IN/BATT CHRG (BATTERY) to “BATTCHRG” in the BDA/MU/RU.
- Ensure the 3<sup>rd</sup> Party 48VDC Power Source is completely powered OFF or disconnected so you will not be connecting live/hot wires.
- Connect the 48VDC Wires from the 3<sup>rd</sup> Party source to the Phoenix connector inside the BDA/MU/RU. The Phoenix connector is removable for ease of installation.

- a. Connect -48VDC to “BATT - “
- b. Connect +48VDC to “BATT +”

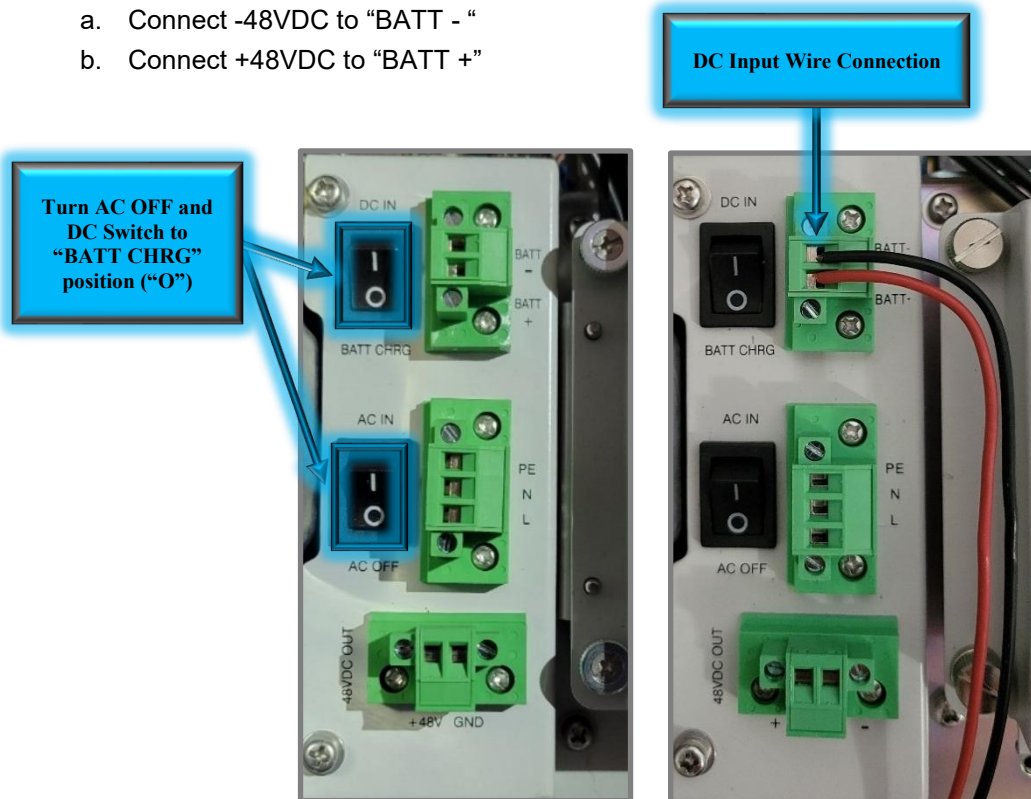

Figure 37: V3 BDA/MU/RU AC Power OFF Switch and Direct 48VDC Power Connection



**Caution: You must follow your local code requirements for guidance on DC Cable installation. See Section 2.13 for additional guidance on installing cable inside of conduit as well as free wiring cable. Please ensure the correct liquid tight connector or cable gland is used accordingly.**

- To power up the system, connect and turn on the 3<sup>rd</sup> Party 48VDC Power Source, and turn the BDA/MU/RU DC Switch to “DC IN”

When the application only calls for +48VDC Power to be fed to the device without any battery backup, the user must login to the device GUI, navigate to the Internal Charger Status/BBU page, and modify the Battery Backup Unit setting to change from “Internal” to “3<sup>rd</sup> party” as shown on Figure 36 above. Otherwise, the BDA/MU/RU will expect to see communication from a Comba V3 BBU and will generate false alarms.

**See the technical application note in Appendix G for more details on connecting a Comba V1/V2 BBU to a V3 BDA/MU/RU.**

## 2.11 V3 BBU WALL MOUNTING

- If applicable, drill eight holes on the wall using the position of eight holes on the BBU mounting bracket as a guide (BBU mounting bracket is built into the BBU cabinet).
- This step will require two people or special lifting equipment. Lift the BBU cabinet (Without Batteries) into position and install the cabinet on the wall. It is recommended to use 3/8" x 1-1/2" lag screws and fender washers when mounting to 3/4" fire treated plywood. If mounting to a concrete wall, DIN Rails, or any other materials, refer to the local building code. Secure the BBU.

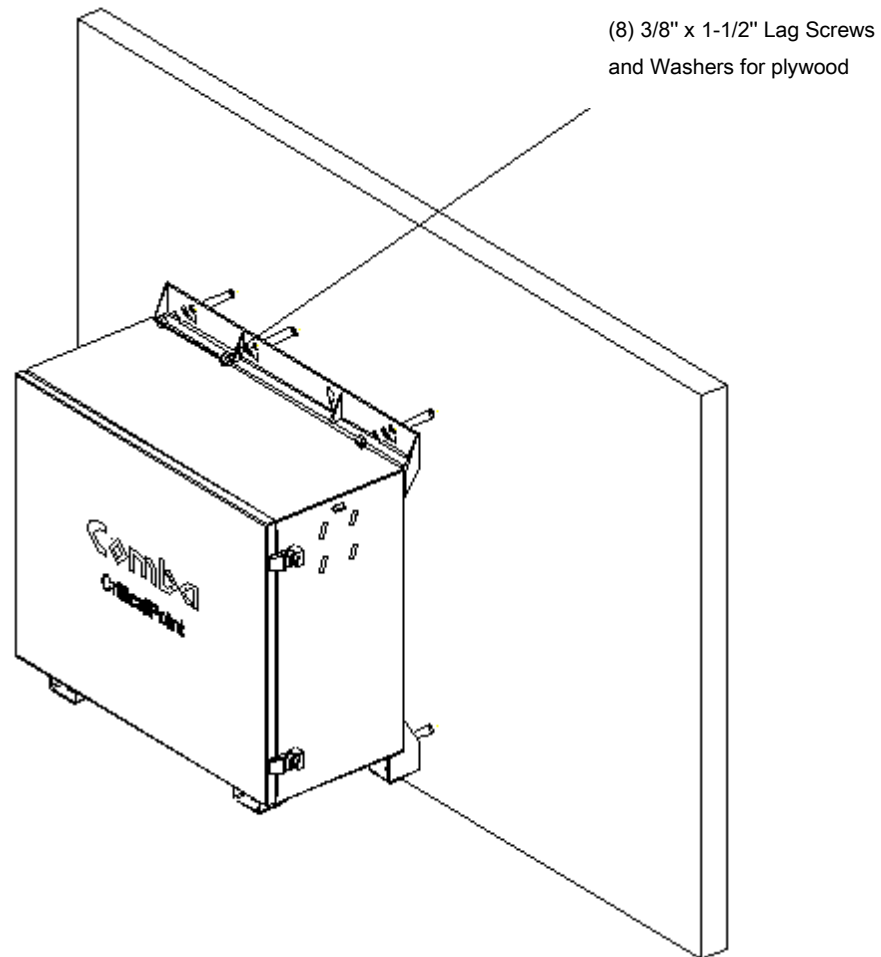

Figure 38: V3 BBU Wall Mounting

## 2.12 V3 BBU LIFEPO<sub>4</sub> BATTERY INSTALLATION AND WIRING

- Install the LiFePO<sub>4</sub> battery into the BBU cabinet as shown in Figure 39. This step may require two people. Gently slide the battery assembly into position.
- Install the battery retaining bracket and secure with 4 x M6 Screws as shown in Figure 39.
- See V2 BBU User Manual or Appendix G for details on connecting V3 BDA to a V2 BBU.

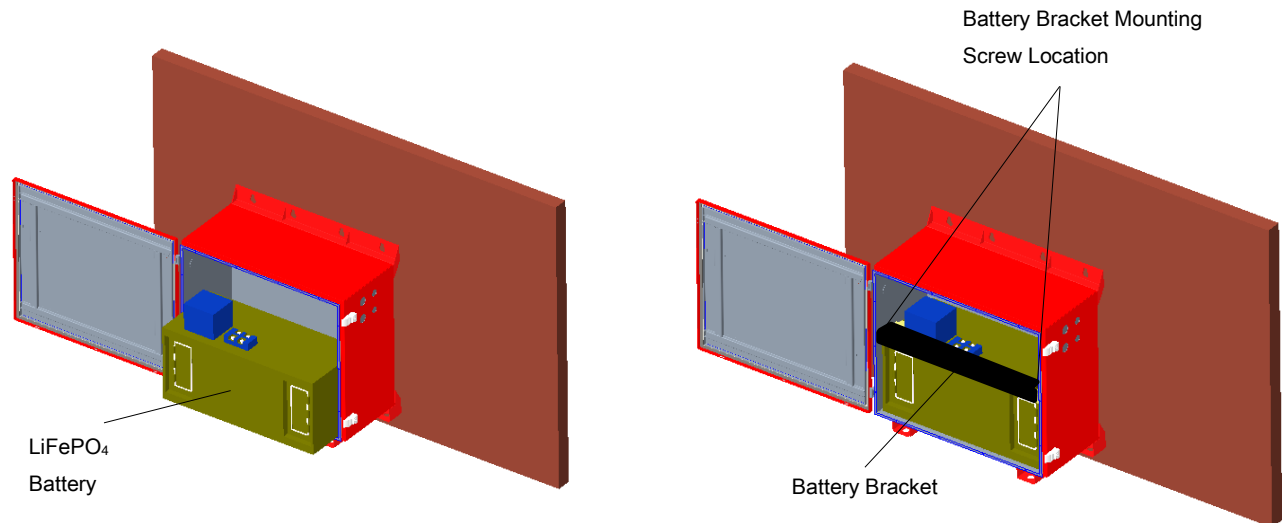

Figure 39: Battery Installation and Retaining Bracket

- Make sure the AC Breaker in the BBU V3 and Battery Breaker on the battery are both OFF.
- Connect the wire(s) labeled “BATT+” to the battery positive (+) terminal; The wire(s) labeled “BATT-” to the battery negative (-) terminal as shown in Figure 40. Due to different design revisions and production batches, wires colors are in one of the following combinations:
  1. 2 x Positive Wires (Black and Brown)  
2 x Negative Wires (Blue and Blue)
  2. 2 x Positive Wires (Black and Black)  
2 x Negative Wires (Blue and Blue)
  3. 1 x Positive Wire (Black)  
1 x Negative Wire (Blue)

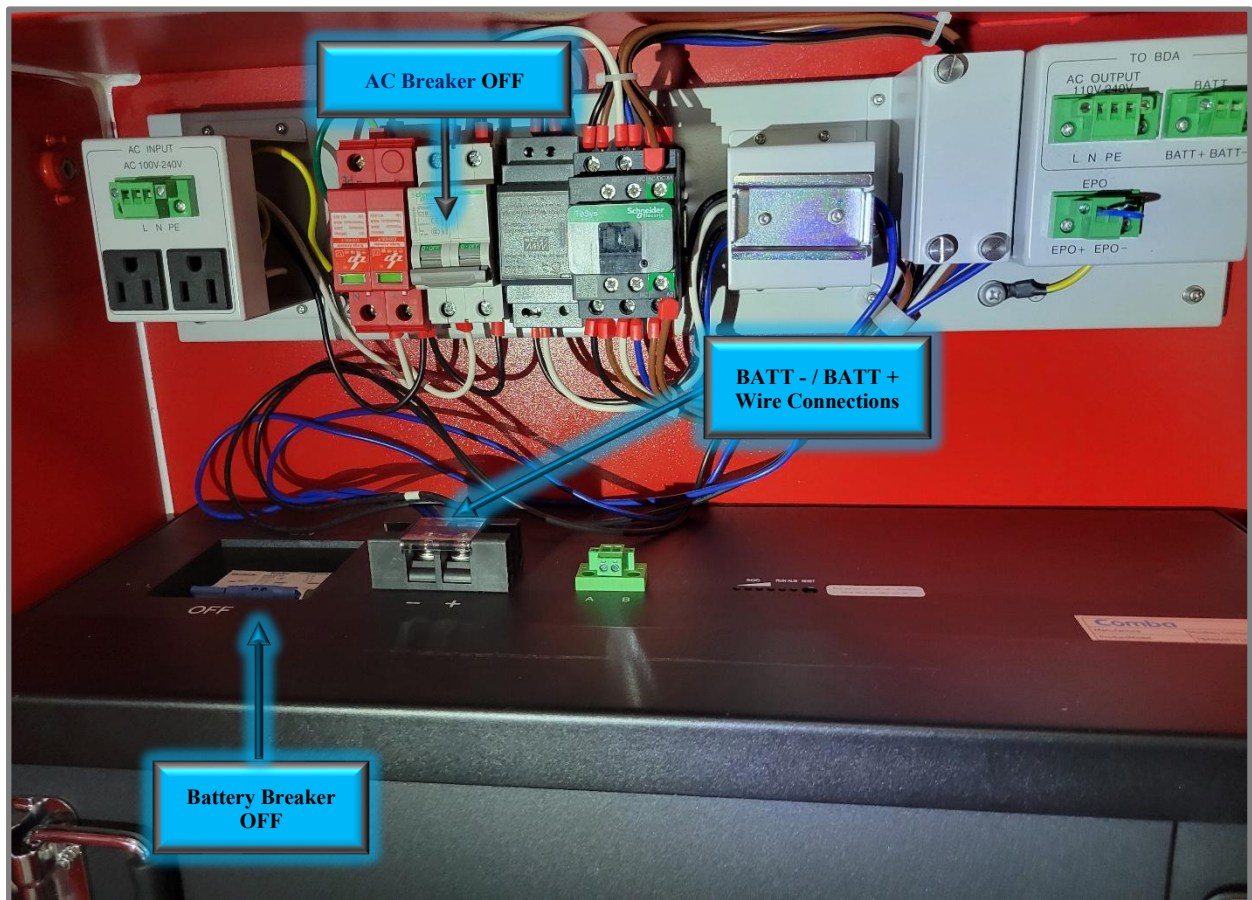

Figure 40: V3 BBU AC Breaker, Battery Breaker, and Battery Wiring

### 2.13 V3 BDA/MU/RU AND BBU SYSTEM WIRING



Comba recommends that every horizontal cable entry to the equipment forms a 'U' before its entry to the equipment. Water on the cable will drip down at the bottom of the loop and will not accumulate at the equipment connectors. This will help prevent corrosion and wear to the metal connectors and cabinet.

Figure 41 shows the Hybrid Cable which is provided with the V3 BBU. The Hybrid Cable carries AC Power from the BBU to the BDA charger, DC Power from the BDA to the battery (path reversed AC Power is lost and batteries are discharging), and RS485 communications from the battery to the BDA. One end of the cable is connectorized from the factory for convenience. This end is to be connected inside the BBU. The other end has sleeved wires and is to be connected inside the BDA/MU/RU.

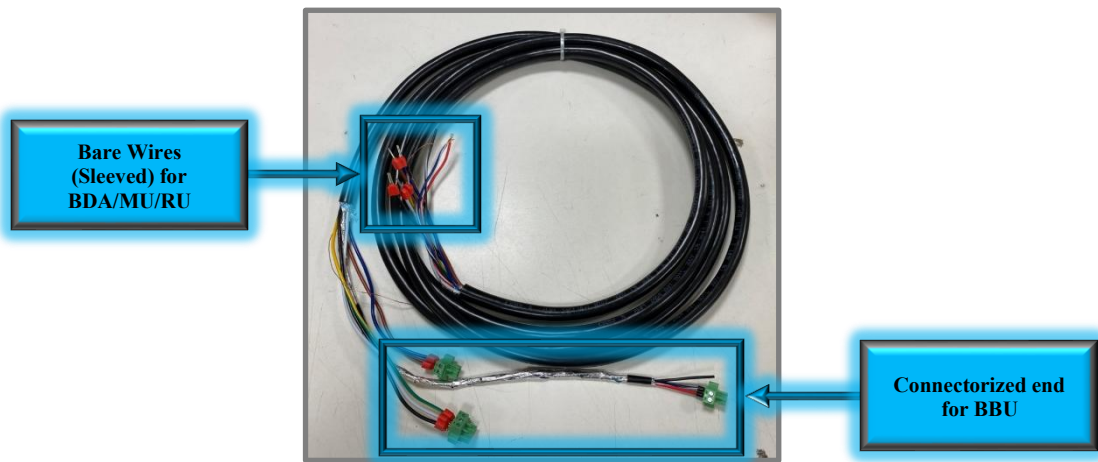

Figure 41: V3 BBU to BDA/MU/RU Hybrid Cable

The copper wire from the Hybrid cable can provide additional shielding for the RS485 wires. It can be connected to the GND connection points in the BBU and BDA shown below in Figure 42.

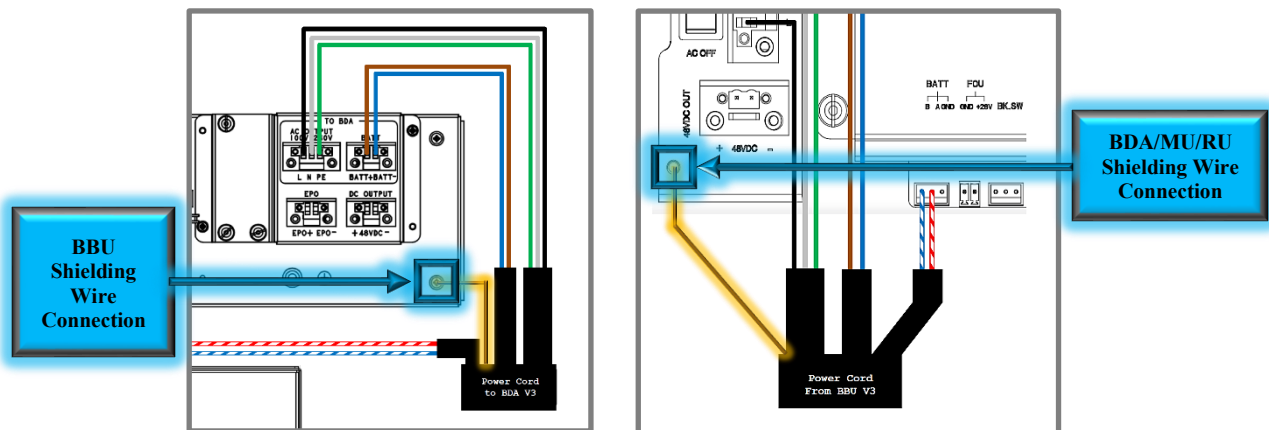

Figure 42: Hybrid Cable Shielding Wire Installation

- Switch both AC IN/AC OFF (POWER) and DC IN/BATT CHRG (BATTERY) to OFF (O) in the BDA/MU/RU as shown in Figure 43 below.

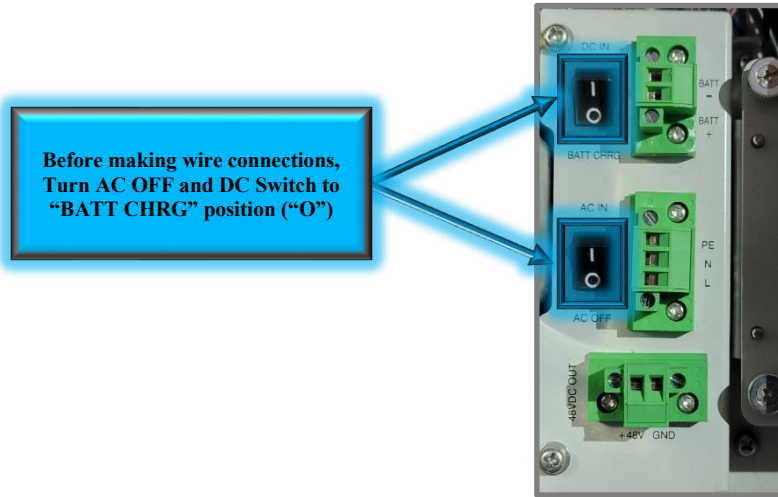

Figure 43: BDA/MU/RU AC and DC Switch OFF

- Connect the connectorized end of the Hybrid cable to the BBU as shown in Figure 44 below.
  1. Connect AC Phoenix connector from Hybrid cable to the AC Output of the BBU.
  2. Connect BATT Phoenix connector from Hybrid cable to BATT of the BBU.
  3. Connect Copper RS485 Shielding Wire to Plate Screw for GND.
  4. Connect RS485 Battery Comms Phoenix connector from Hybrid cable to A&B of the BBU.
  5. Secure all Phoenix connectors by tightening screws using a small flathead screwdriver.

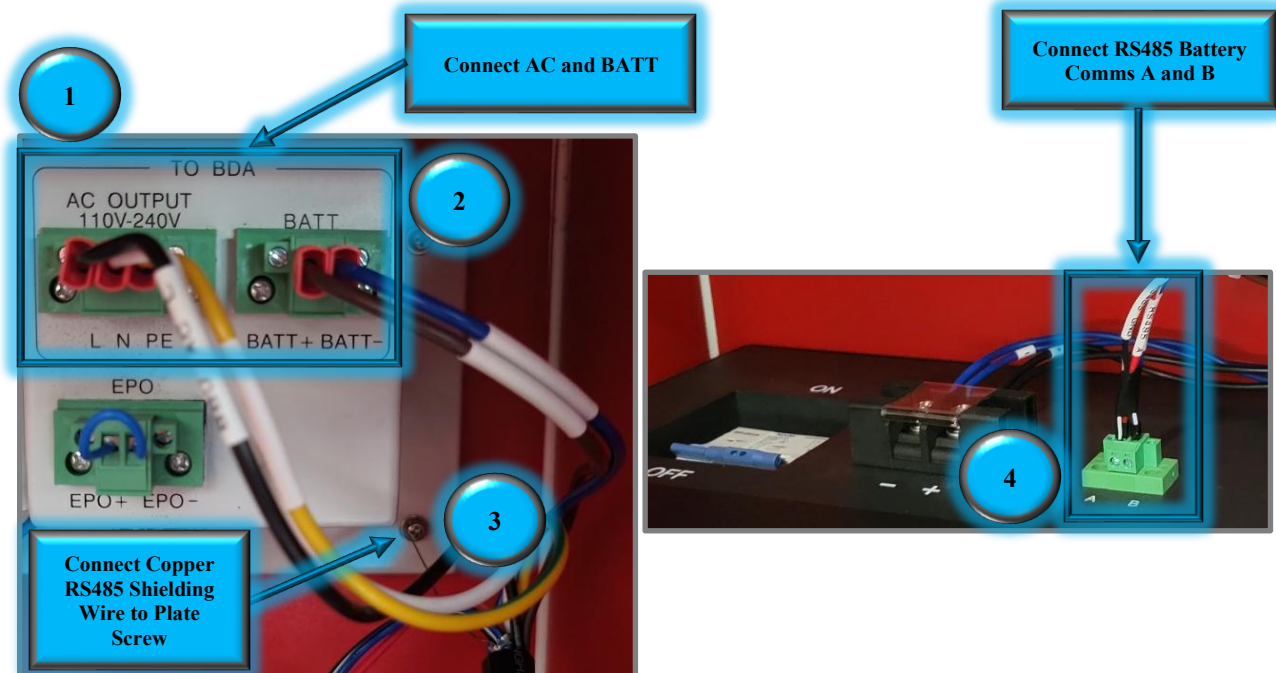

Figure 44: Hybrid Cable Connection in BBU

- Run the Hybrid cable through a knockout on the BBU to a knockout on the BDA/MU/RU then into the BDA/MU/RU for connection. It is recommended to use the 3/4" knockouts for ease of installation. The cable can run through a conduit between the BBU and BDA/MU/RU as shown in Figure 45. If using conduit, liquid tight conduit connectors, as shown in Figure 46, must be installed to maintain the UL50E Type 4 rating for waterproofing. These connectors are not included and must be provided by the installer.
- Alternatively, the Hybrid Cable can be free-wired between the BDA/MU/RU and BBU knockouts. If you are free wiring the Hybrid Cable, you must do so using the provided 3/4" liquid tight cable glands to maintain the UL50E Type 4 rating for waterproofing. These cable glands are included and are shown below in Figure 47.

Note: Always follow your local code requirements.

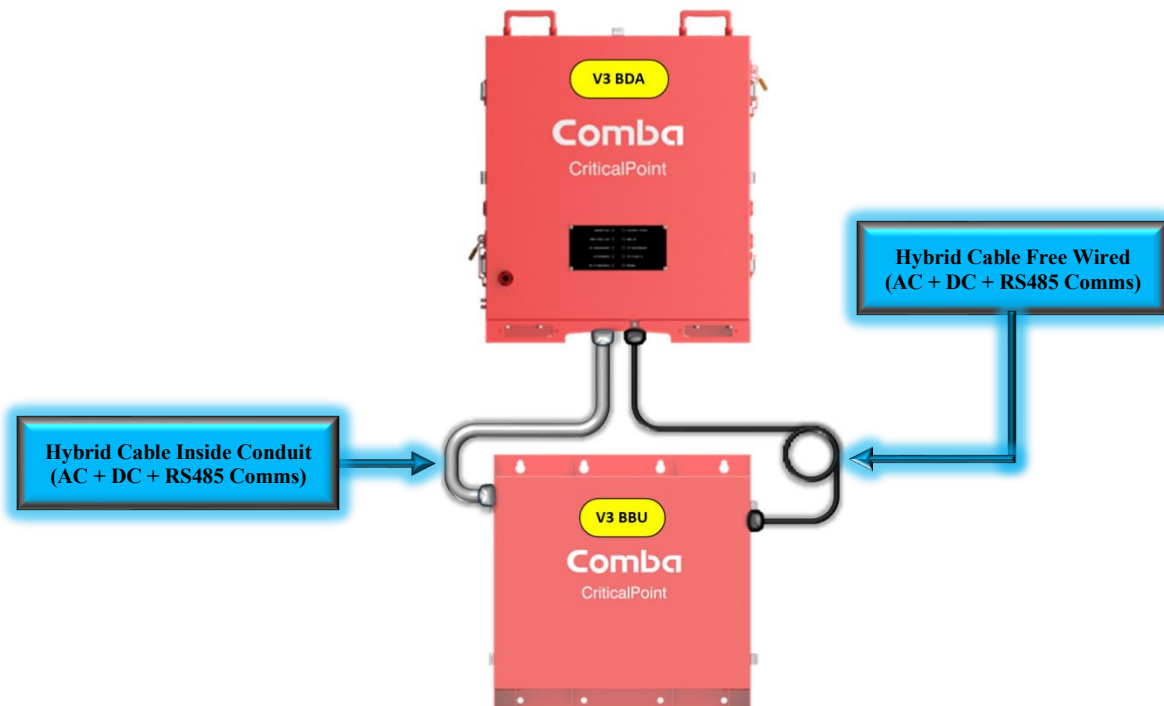

Figure 45: V3 BBU to V3 BDA/MU/RU Hybrid Cable Installation Example



Figure 46: Liquid Tight Conduit Connector



Figure 47: Liquid Tight Cable Gland

- Connect the sleeved wires to the Phoenix connectors inside the BDA/MU/RU as shown in Figure 48 below. The Phoenix connectors are removable for ease of installation.
  1. Connect AC Wires
    - a. Connect (AC) Black Wire to L
    - b. Connect (AC) White Wire to N
    - c. Connect (AC) Green/Yellow Wire to PE (GND)
  2. Connect Battery Wires
    - a. Connect (DC) Brown Wire to BATT+
    - b. Connect (DC) Blue Wire to BATT-
  3. Connect Battery RS485 Wires
    - a. Connect (Battery Comm.) Red/White Wire to BATT A
    - b. Connect (Battery Comm.) Blue/White Wire to BATT B
    - c. (Battery Comm.) Black Wire is not used
  4. Connect RS485 Shielding Wire
    - a. Connect Copper RS485 Shielding Wire to Plate Screw for GND
  5. Secure all Phoenix connectors by tightening screws using a small flathead screwdriver.

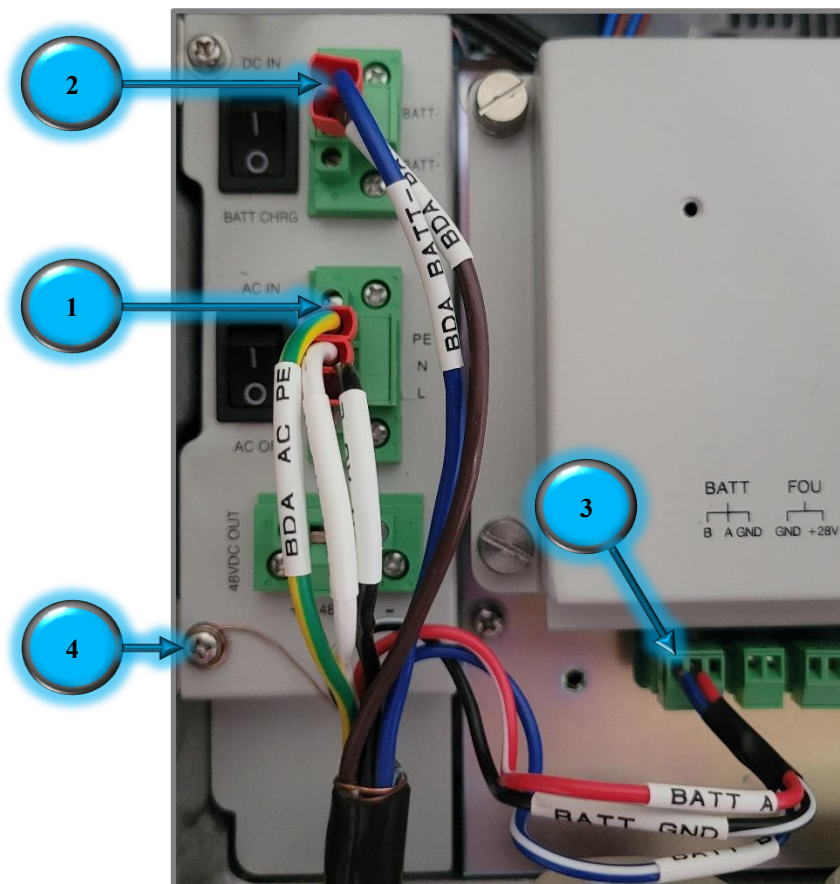

Figure 48: V3 BDA/MU/RU Hybrid Cable Wire Connections

## 2.14 V3 BBU AC INPUT, EPO CONNECTION, AND CONVENIENT AC OUTLETS

- Make sure the AC breaker is OFF in the BBU.
- Connect the AC input into the BBU, as shown below in Figure 49.

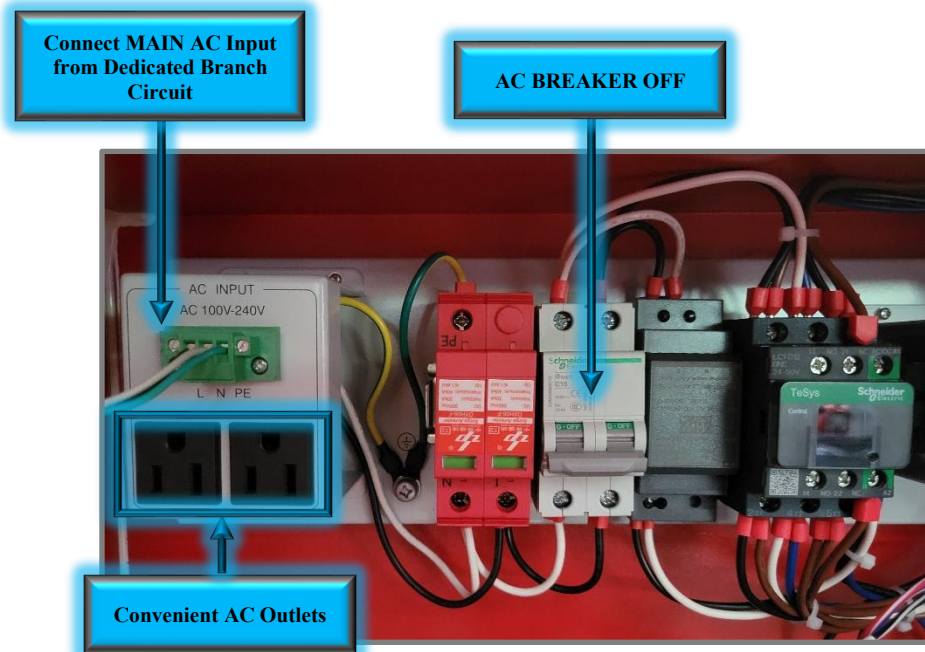

Figure 49: V3 BBU AC Input, AC Breaker OFF, and AC Convenience Outlets

- Run the Main AC Cable through a knockout on the BBU into the BBU for connection. It is recommended to use a 1/2" knockout for ease of installation. The cable can run through a conduit from a hardwired dedicated branch circuit to the BBU as shown in Figure 50. If using conduit, a liquid tight conduit connector, as shown in Figure 46, must be installed to maintain the UL50E NEMA 4 rating for waterproofing. This connector is not included and must be provided by the installer.
- Alternatively, the AC Cable can be free wired between a dedicated branch circuit to the BBU knockout if permitted by the AHJ. If you are free wiring the AC Cable, you must do so using the provided 1/2" liquid tight cable gland to maintain the UL50E NEMA 4 rating for waterproofing. This cable gland is included and is shown in Figure 47.

Note: Follow your local code requirements.

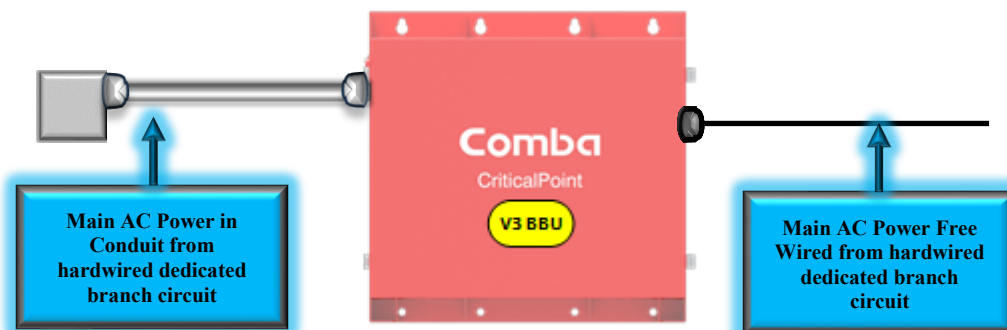

Figure 50: V3 BBU Main AC Input Installation Example



**CAUTION.** There are two convenient AC Outlets provided next to the AC Input. See Figure 49. These are to be used for convenience during commissioning for items like laptops, cell phones chargers, RF Test Equipment, etc. The AC Outlets are in parallel with the MAIN AC Input and are not backed up by battery power. Do not permanently connect any components to the outlets for general system use as they will not work per the code requirements when normal AC power is lost. Furthermore, code requirements mandate the Signal Booster System Components are fed from a dedicated circuit. The AC Outlets should be empty during normal operation after system commissioning.

- The EPO connector should be either connected to an external EPO (Require **Normally Closed EPO**) or leave it shorted, as shown in Figure 51. If using an EPO switch connect it now. The EPO function, by default, will disconnect both Main AC Input Power as well as disconnect the Backup Battery Power. The user can access the EPO bypass switches by removing the 3 screws and removing the cover plate. The user can bypass either the AC EPO disconnect or the DC EPO disconnect function by turning the corresponding switch ON. See the following EPO Wiring Diagram in Figure 52 for more details.

**Note: Voltage drop for extension of the EPO should be <20V.**

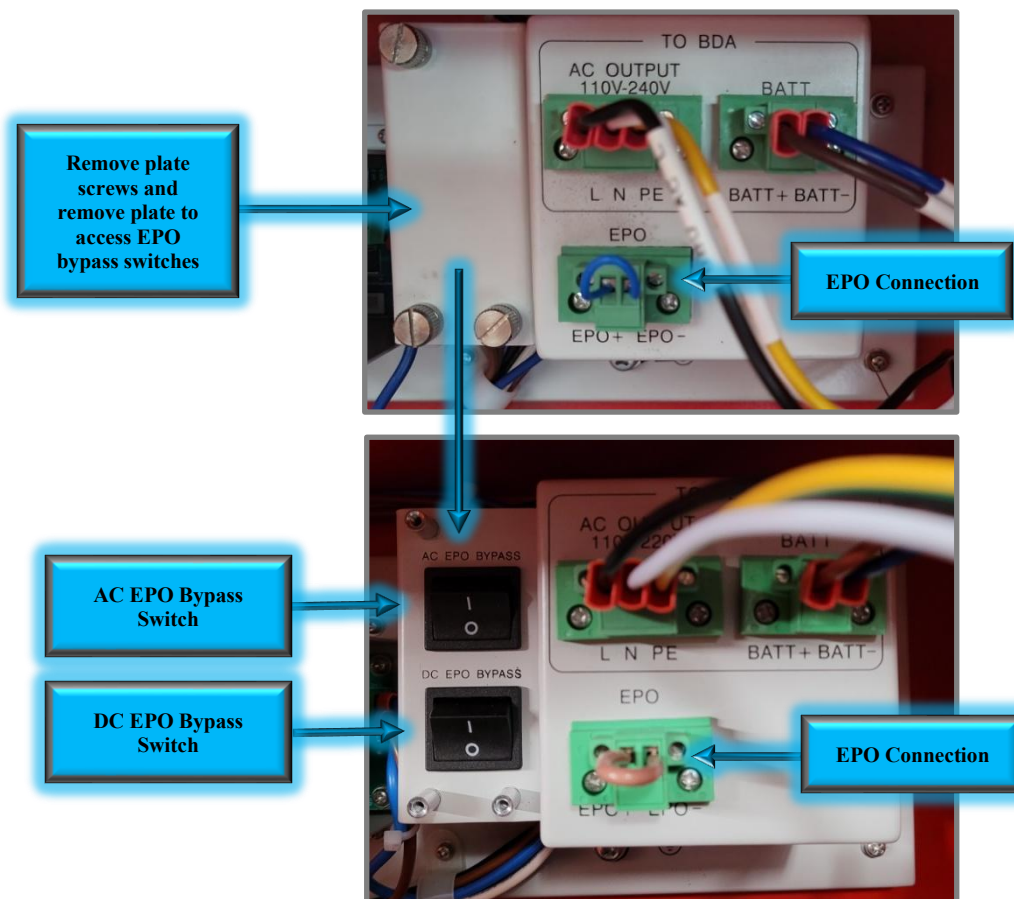

Figure 51: V3 BBU EPO Switch Connection

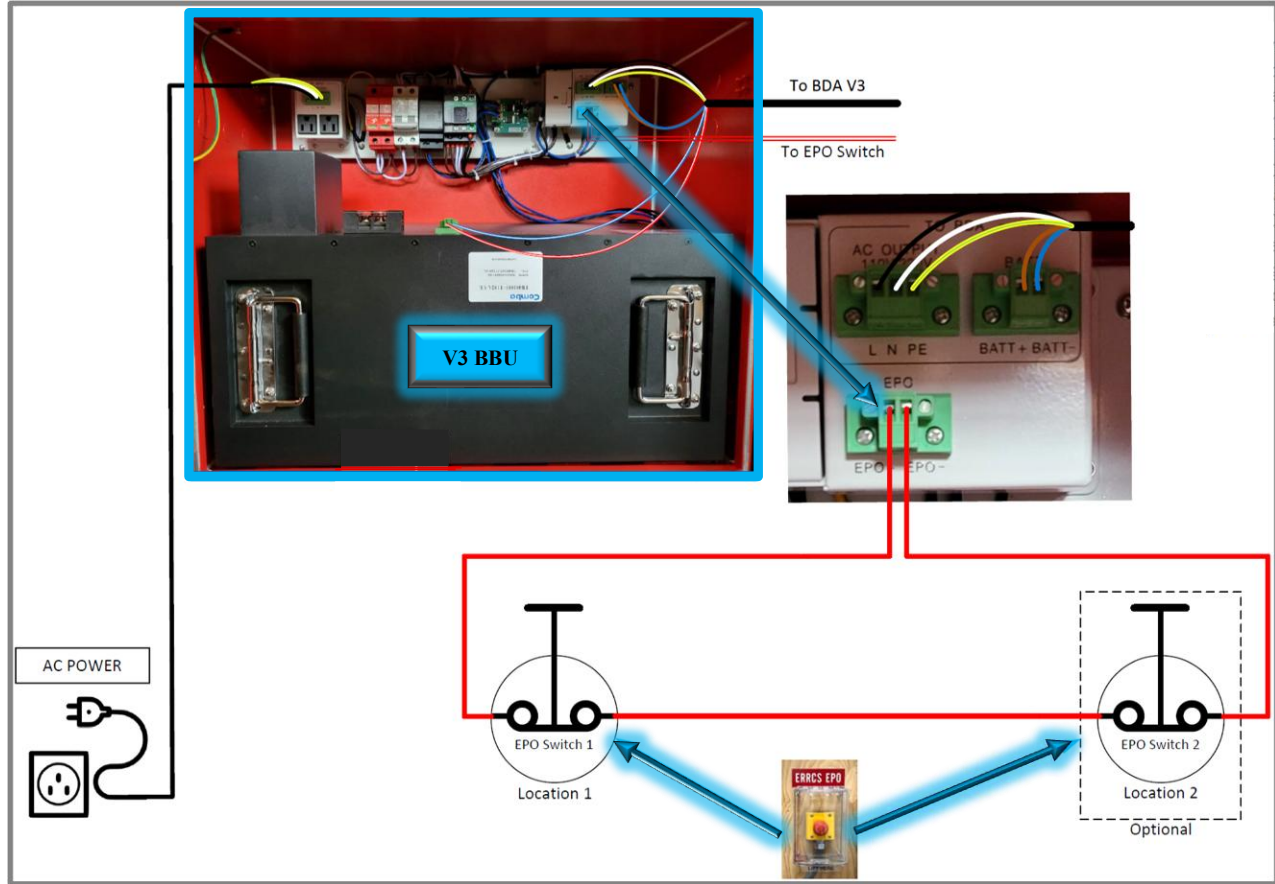

Figure 52: EPO Switch Wiring Diagram

Table 6: V3 BBU and EPO Relay Specifications

Parameter	Value
EPO Relay Control Circuit Voltage:	24-60VDC
EPO Relay Current:	<100mA
BBU Battery Nominal Voltage	51.2VDC
BBU Cut-off Threshold	46VDC

**EPO Installation Notes:**

1. The EPO connections have a pre-installed wire that shunts the EPO+ and EPO- terminals. Remove the pre-installed wire and connect the EPO switch; then turn the EPO switch to its “Closed” position (Normal Status).
2. DO NOT set the EPO switch to “Open” (Cut-off Status).
3. The EPO switch can be installed at a remote location, but the voltage drop should be considered before installing.
4. The EPO function is triggered from a relay and this relay is energized by the battery or the charger; if the battery is over-discharged, then the EPO function may not work properly.
5. If you do not wish to use an EPO switch, do NOT remove the pre-installed shorting wire!
6. To bypass the AC disconnect function of the EPO, turn ON the AC EPO Bypass switch.
7. To bypass the DC disconnect function of the EPO, turn ON the DC EPO Bypass switch.

## 2.15 V3 BDA/MU/RU ADDITIONAL DC OUTPUTS

There are three direct DC outputs from the BDA/MU/RU:

1. FOU (+28V/GND) in the BDA: DC28V
2. AUX (+28V/GND) in the BDA: DC28V
3. 48VDC OUT (+ 48VDC -) in the BDA: DC48V (Typical 53.5V, Nominal 51.2V)

These are shown below in Figure 53.

The two DC28V outputs, FOU and AUX, are reserved for Comba FOUs and Annunciator Panels respectively, but can be used for other devices if they are vacant and will not be used in a future expansion of the project.



General Warning

**Alert! All negative terminals from the 48VDC and 28VDC outputs are tied to the ground! Use only for +48V/+28VDC or floating DC input devices. No -48V/-28VDC connections are allowed!**



General Warning

**Alert! The Total Power Load the BBU PSU/Charger can support is 205W. The V3 BDA/MU/RU has a power consumption of 100W. The FOU has a power consumption of 25W. The external AP has a power consumption of 3W. When connecting devices to the DC outputs make sure you do not exceed the Total Power Load rating!**

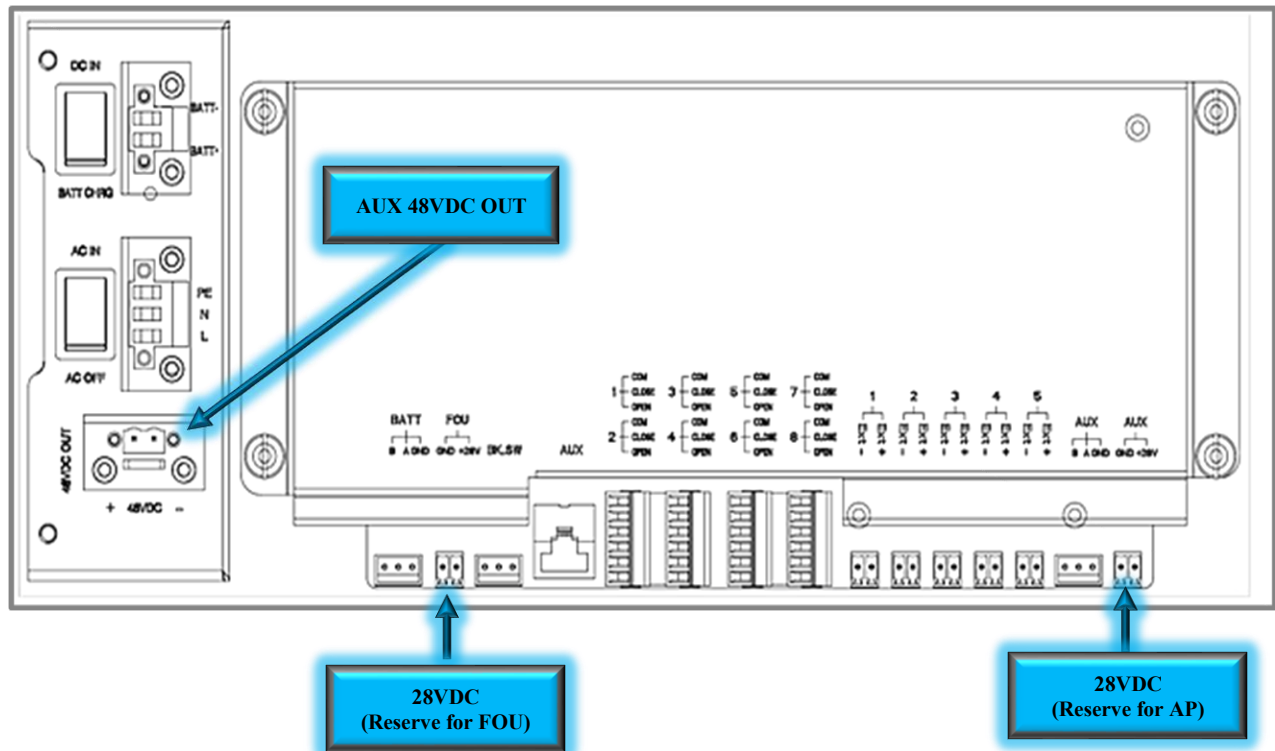

Figure 53: V3 BDA/MU/RU Additional DC Outputs

There is a small convenience DIN Rail located inside the V3 BBU which can be used for third party DC-DC converter module mounting (used to convert 48VDC to 12VDC or 24VDC output). A common application is to feed a 3<sup>rd</sup> Party DC-DC converter module from the BDA/MU/RU 48VDC output. See Figure 54 below.

Do not connect any battery outputs directly to the DC-DC converter module!

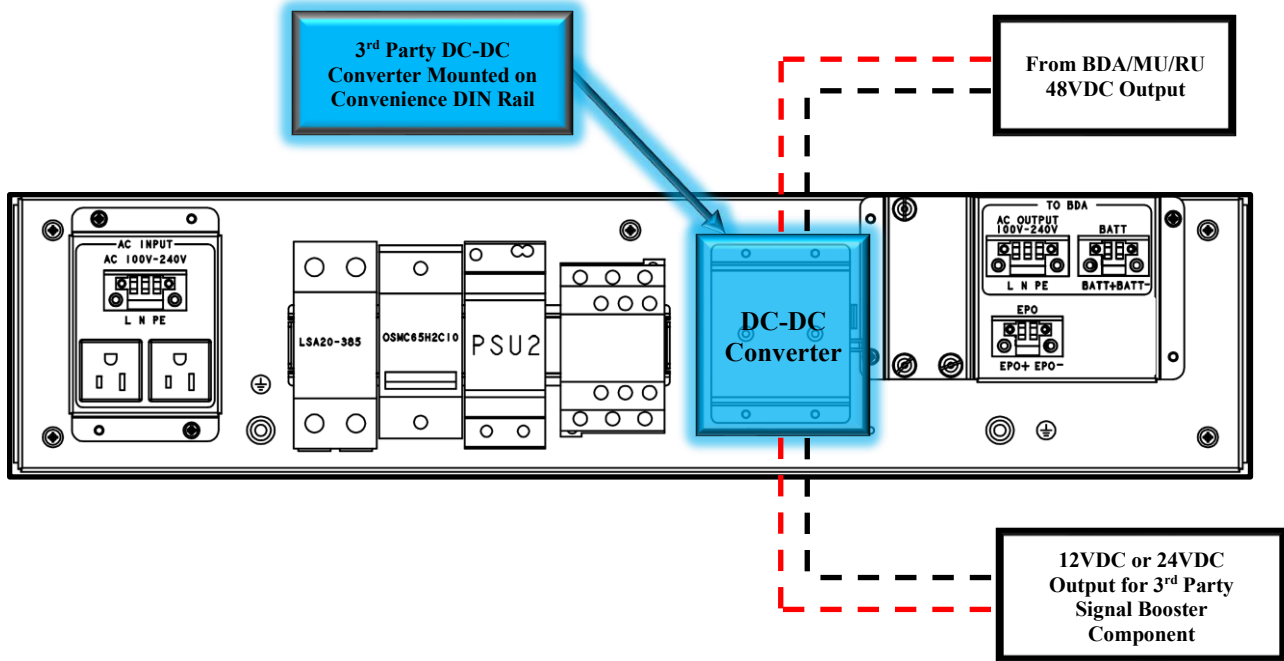

Figure 54: Mounting and Wiring DC/DC/Converter to V3 BBU Convenience DIN Rail

**Note:** A common application utilizing the above DC/DC converter configuration is when an authority requires a 12VDC Auto-dialer.

See the technical application note in Appendix H for more details on connecting an auto-dialer to a Comba V3 BBU.

## 2.16 V3 SYSTEM ALARM CONNECTION

### Dry Contact Alarms:

The V3 BDA/MU and RU have 8 dry contact outputs, each one supports either Normally Open or Normally Closed operation. For Normally Closed operation use the “CLOSE” and “COM” terminals. For Normally Open operation use the “OPEN” and “COM” terminals. The user can configure each of the 8 dry-contact alarm outputs through the software GUI. There are default alarm configurations in the software GUI that match the annunciator front plates that are included with the unit. Furthermore, for non-standard/custom alarm configurations, the user can select which internal device alarms will trigger each dry-contact alarm output. In the Fiber DAS configuration, RU alarms are also mirrored and generated at the BDA/MU Dry Contact Contacts such that the entire system of alarms can be summarized at the BDA/MU. EOL (End-of-Line) Resistors can be installed across the Dry Contact Alarm terminals. The Phoenix Alarm Connectors are removable for ease of wire installation.

### External Alarms:

The V3 BDA/MU/RU has 5 external alarm inputs which can accept dry contact outputs from external devices. These external alarms can be setup in the software GUI to trigger from a Normally Open or Normally Closed device trigger. Furthermore, the external alarm inputs can be configured to trigger one or more of the dry-contact alarm outputs. Additionally, any of the external alarm inputs can be configured to control the RF and shut down the RF amplifiers through the software. This allows for a quick RF Shut Down by a simple push of a button (Example EPO Switch). The External Alarm 5 is pre-configured from the factory as the “Door Open Alarm”. If the user does not wish to use the Door Open Alarm or requires the External Alarm 5 for a different device, the Door Alarm wires must be removed. Please ensure the device is completely powered down before making this wire connection. Install the new device wires in External Alarm 5 and reconfigure accordingly in the software GUI.

**For detailed instructions on how to configure alarms in the software GUI, refer to the Commissioning and Alarms sections of this manual!**

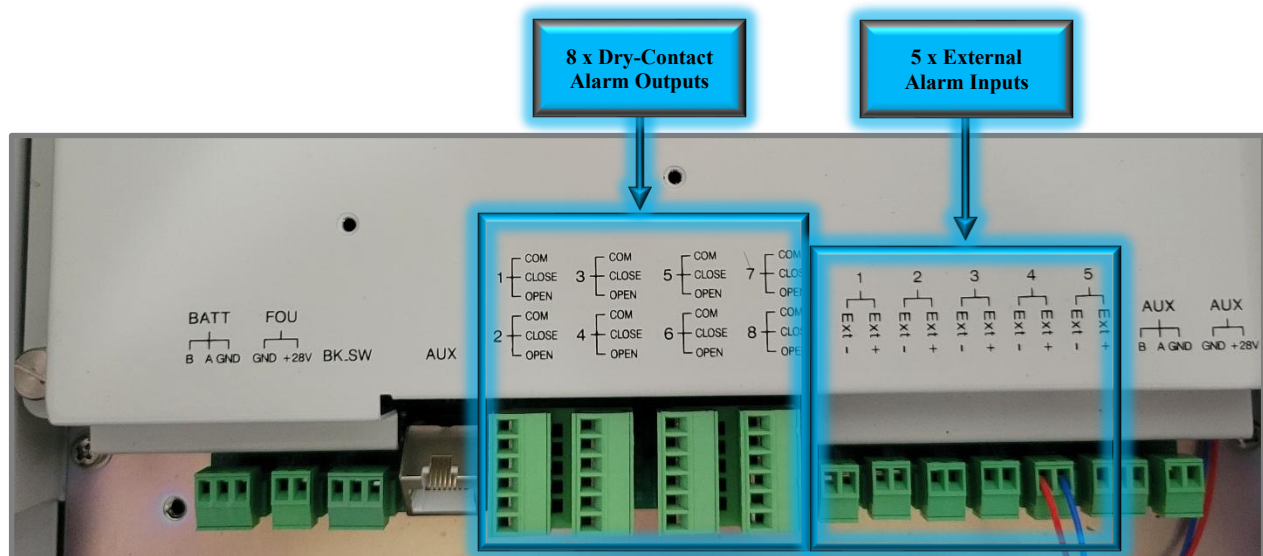

Figure 55: V3 BDA/MU/RU Dry-Contact Output and External Input Alarms Connection

See Figure 56 below for a typical supervisory alarm connection from the BDA/MU/RU to a Fire Alarm Panel. The example below shows the BDA/MU feeding 7 alarms to the fire alarm panel per the UL2524 2<sup>nd</sup> Rev 2018 standard. This is a common configuration, and Comba provides a setting in the software GUI to easily configure these alarms. Also, as described in the General Information section, Comba provides several different front-panel annunciator plates with BDA/MU/RU to match the specific alarm configuration required by your authority. See Section 2.17 for instructions on how to install/replace the annunciator front plate.

Note: In the Fiber DAS configuration, RU alarms are also mirrored and generated at the BDA/MU Dry Contacts such that the entire system of alarms can be summarized at the BDA/MU.

Example: If a RU has a “Loss of Normal AC Power” Alarm, the Dry Contact #1 alarm will be triggered at both the RU and BDA/MU.

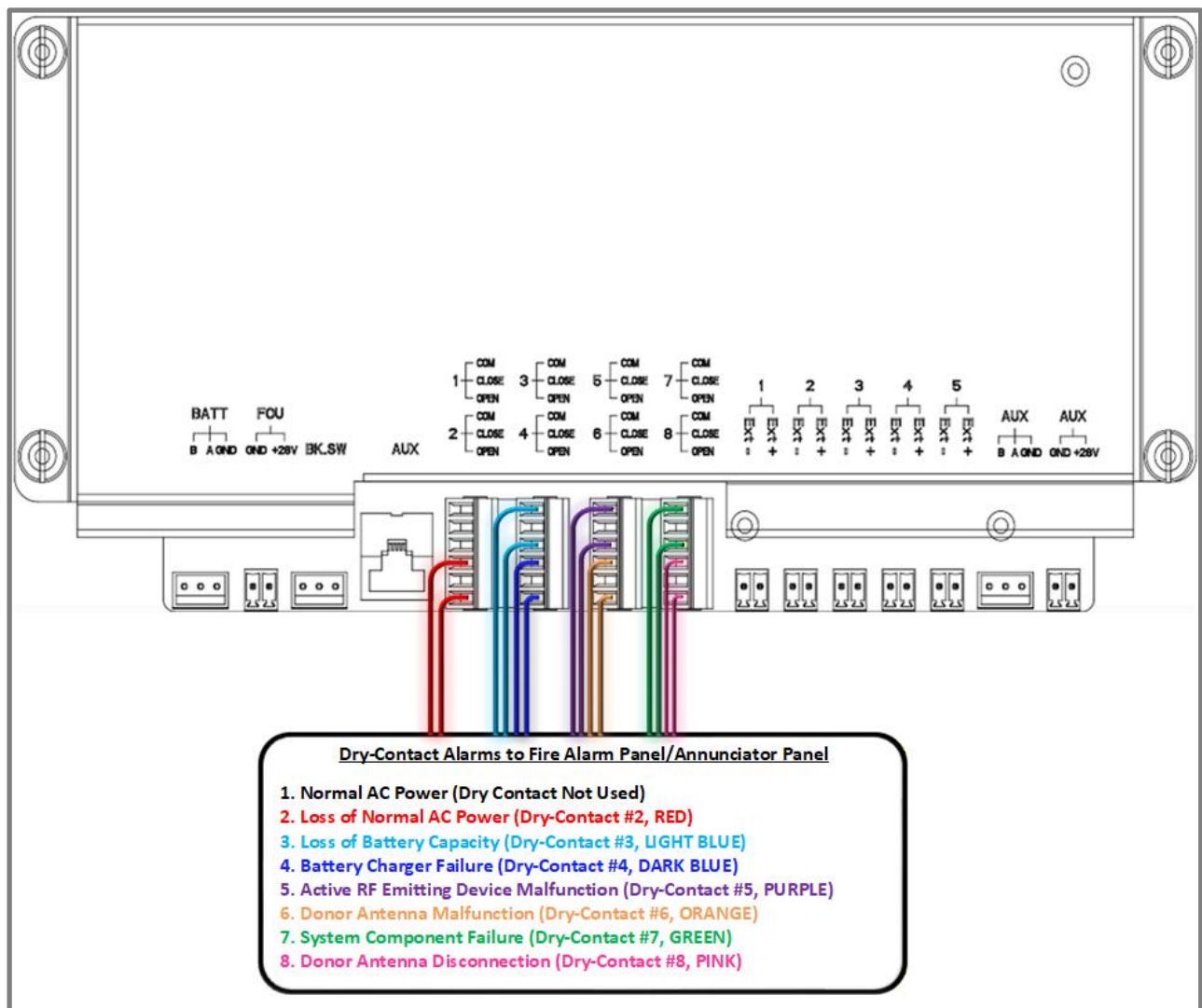

Figure 56: V3 BDA/MU/RU NO Dry-Contact Alarm Wiring Example – UL2524 2<sup>nd</sup> Rev Oct 2018

## 2.17 V3 BDA/MU/RU ANNUNCIATOR FRONT PLATE INSTALLATION

The V3 BDA/MU and V3 RU come from the factory with 5 different front plate options for the built-in alarm annunciator panel on the front of the device. This allows the user to choose the front panel plate that matches the authority's code requirements. The NFPA1221 2019 Alarm plate installed from the factory.

To replace the factory installed plate:

- Remove the 4 screws and washers holding the factory installed plate in place. This hardware will be reused. Do not discard! See Figure 57 for screw locations.
- Position the desired plate such that all 4 cabinet screw holes are aligned with the holes in the new plate.
- Secure the plate using the 4 screws and washers.

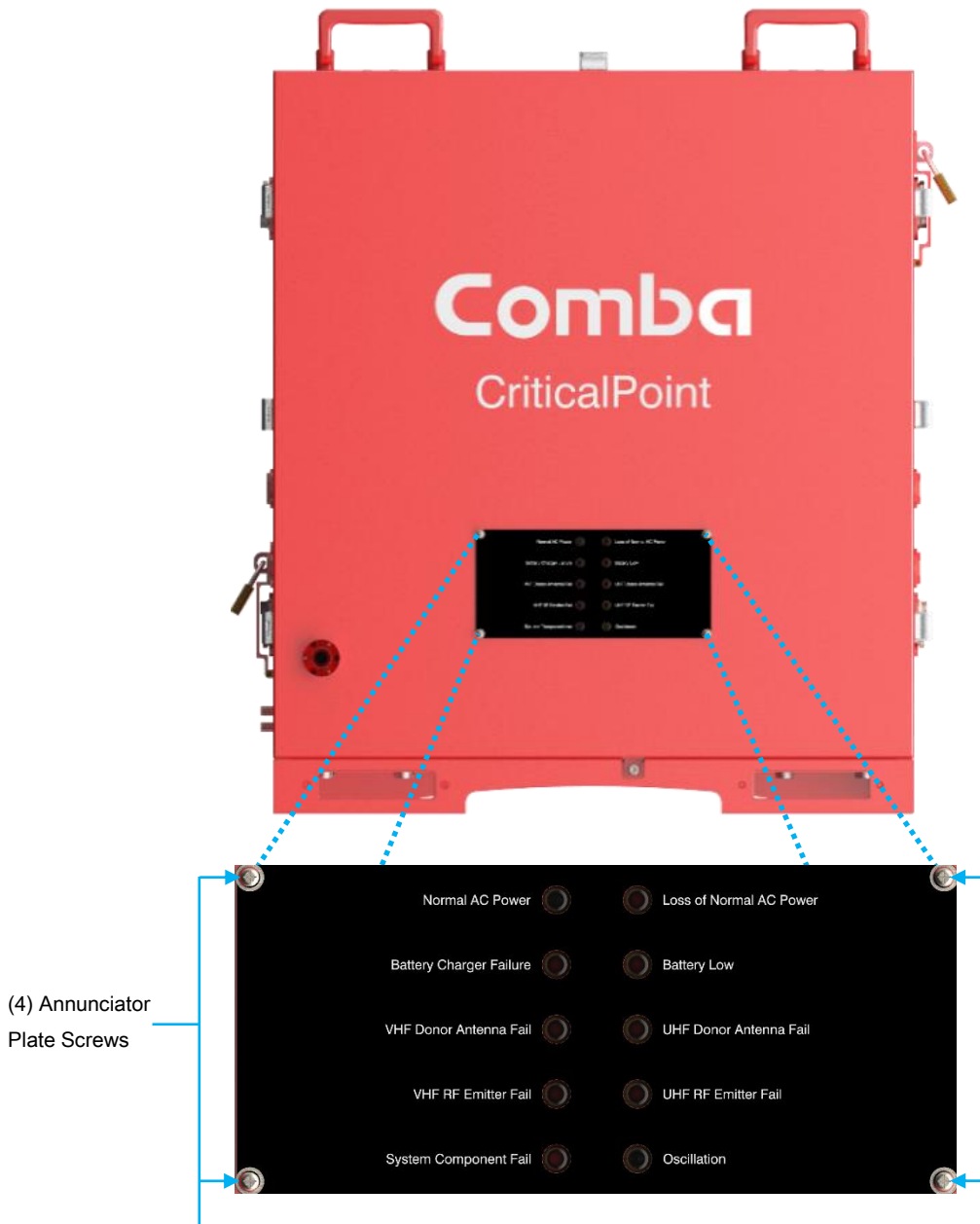







Figure 57: V3 BDA/MU/RU Annunciator Front Plate Installation

See Table 7 below for details about the annunciator front plate options and alarm configurations.

Table 7: V3 BDA/MU/RU Annunciator Front Plate Options

Alarm Configuration	Annunciator Alarm LEDs	
UL2524 2 <sup>nd</sup> Rev Oct 2018	<ol style="list-style-type: none"> <li>1. AC Input Normal</li> <li>2. Loss of Normal AC Power</li> <li>3. Loss of Battery Capacity</li> <li>4. Battery Charger Failure</li> <li>5. Active RF Emitting Device Malfunction</li> <li>6. Donor Antenna Malfunction</li> <li>7. System Component Malfunction</li> <li>8. Donor Antenna Disconnection</li> <li>9. RUN</li> <li>10. ALM</li> </ol>	
NFPA1221 2019 (Default)	<ol style="list-style-type: none"> <li>1. Normal AC Power</li> <li>2. Loss of Normal AC Power</li> <li>3. Battery Charger Failure</li> <li>4. Low-Battery Capacity</li> <li>5. Donor Antenna Malfunction</li> <li>6. Active RF-Emitting Device Malfunction</li> <li>7. Active System Component Malfunction</li> <li>8. RUN</li> <li>9. ALM</li> </ol>	
IFC510 2021	<ol style="list-style-type: none"> <li>1. Loss of Normal AC Power Supply</li> <li>2. System Battery Charger(s) Failure</li> <li>3. Malfunction of the Donor Antenna(s)</li> <li>4. Failure of Active RF-Emitting Device(s)</li> <li>5. Low-Battery Capacity at 70% Reduction of Operating Capacity</li> <li>6. Failure of Critical System Components</li> <li>7. ERRCS Annunciator Panel Communication Alarm</li> <li>8. Oscillation of Active RF-Emitting Device</li> <li>9. RUN</li> <li>10. ALM</li> </ol>	
NFPA1225 2022	<ol style="list-style-type: none"> <li>1. Normal AC Power</li> <li>2. Loss of Normal AC Power</li> <li>3. Battery-Charger Failure</li> <li>4. Low-Battery Capacity</li> <li>5. Signal Source Malfunction</li> <li>6. Active RF-Emitting Device Malfunction</li> <li>7. Active System Component Malfunction</li> <li>8. RUN</li> <li>9. ALM</li> </ol>	
User Defined	<ol style="list-style-type: none"> <li>1. Blank</li> <li>2. Blank</li> <li>3. Blank</li> <li>4. Blank</li> <li>5. Blank</li> <li>6. Blank</li> <li>7. Blank</li> <li>8. Blank</li> <li>9. RUN</li> <li>10. ALM</li> </ol>	

## 2.18 V2 FOU WALL MOUNTING

The V2 FOU has 4 x mounting brackets. Two of the mounting brackets are attached to the FOU from the factory and the other two are in the accessory kit.

- Remove the two mounting brackets that come attached to the V2 FOU from the factory, adjust the direction according to Figure 58, and install the remaining 2 mounting brackets from the accessories kit.
- Drill 8 holes on the wall/plywood using the position of eight holes on the V2 FOU mounting brackets as a guide.
- Install the V2 FOU cabinet on the wall as shown in Figure 59. It is recommended to use 3/16" x 1-1/2" screws and fender washers when mounting to 3/4" fire treated plywood. If mounting to a concrete wall, DIN Rails, or any other materials, refer to the local building code.

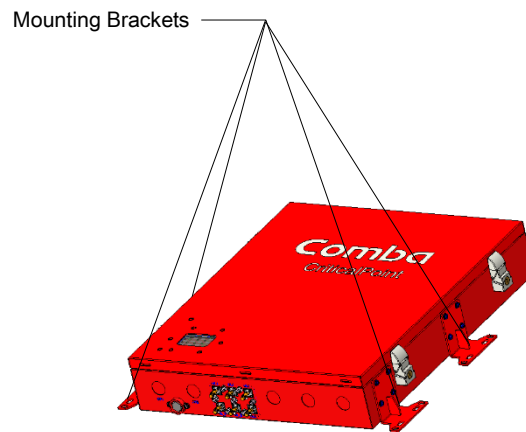

Figure 58: V2 FOU Installing and Adjusting Mounting Brackets

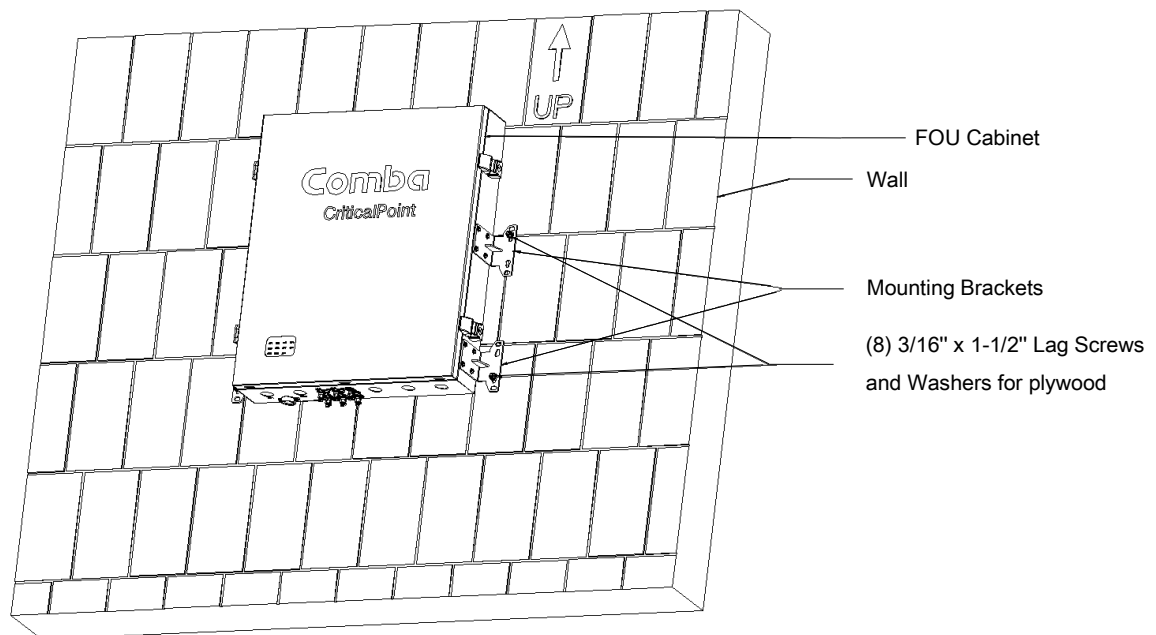

Figure 59: V2 FOU Wall Mounting

## 2.19 V2 FOU 19IN RACK MOUNTING

The FOU can also be mounted into a 19in rack. There are two separate ways to mount it in a 19in rack. The FOU can be mounted vertically with the door and status LEDs facing outward. This is the recommended rack mount method to allow door clearance and accessibility. However, the device will occupy more rack space. Alternatively, the FOU can be mounted horizontally in a 19in rack. In this configuration, the RF Ports and Knockouts are facing outward. However, the status LEDs and the door are facing upwards, which is not ideal. This configuration occupies less rack space but provides less accessibility.

For the above-described cases, you must adjust the FOU mounting brackets as shown in Figure 60 below. Once the mounting brackets are adjusted correctly, you can secure the device to the 19in rack using 4 x rack screws (not provided).

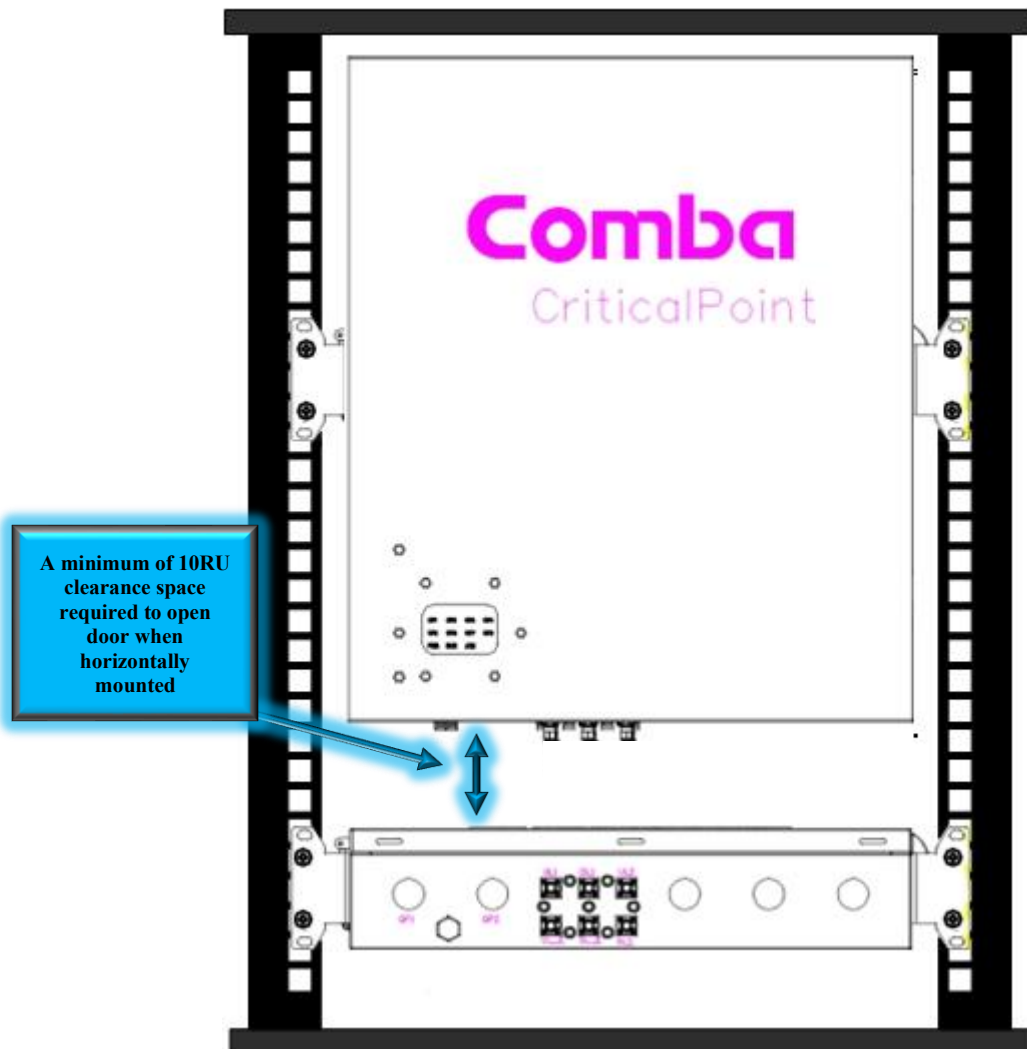

Figure 60: V2 FOU 19in Rack Mounting

## 2.20 V2 FOU POWER AND COMMUNICATIONS WIRING

- Ensure all equipment (BDA/MU, BBU, and third-party power sources) is powered down and all power switches are in the OFF position. Refer to previous sections for power switch locations.
- Turn OFF FOU Power Switch
- Connect BDA/MU to FOU(See Figure 61):
  1. BDA/MU FOU (+28V, GND) to FOU IN1
  2. BDA/MU AUX (Ethernet Port) to FOU AUX1

Note: The DC Power Cable and Ethernet RJ45 cable are both included with the V2 FOU. These cables are both approximately 5ft in length. If the length is not sufficient for the installation, you must source a longer cable from a third party. Make sure to follow the local code requirements.

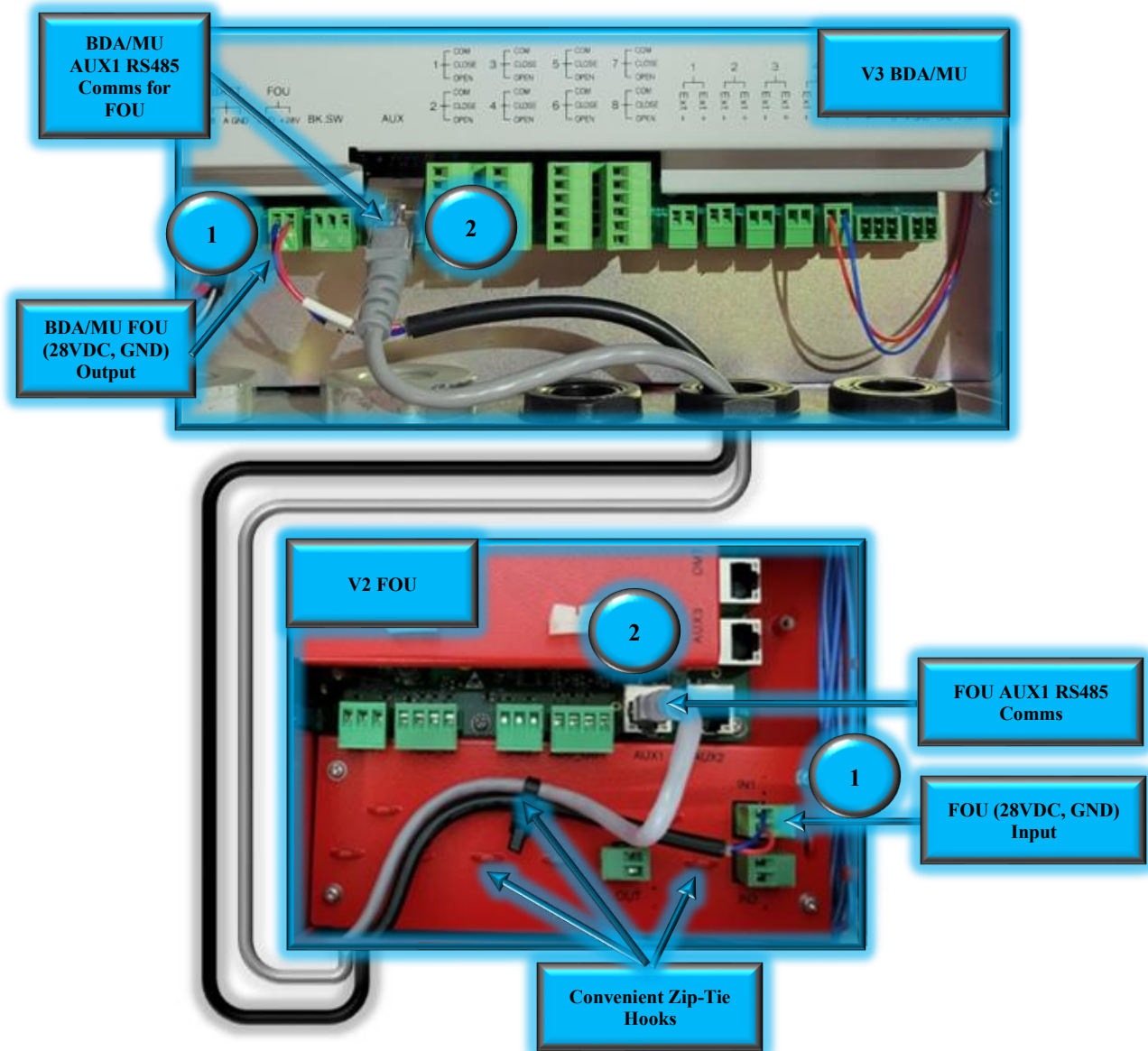

Figure 61: V3 BDA/MU to and V2 FOU Power and Communication Wiring

If there is more than one FOU required, connect as shown below in Figure 62. The Figure shows an example of cascading 2 FOU's from a BDA/MU. Follow the same concept to cascade to a maximum of 4 FOU's.

Follow the below instructions when using more than one FOU:

- Install Address Cable between FOU(n) "ADD. OUT" to FOU(n+1) "ADD. IN" (cable not provided)
- Install DC Power cable between FOU(n) "OUT" to FOU(n+1) "IN1"
- Install ethernet RJ45 cable between FOU(n) "AUX3" to FOU(n+1) "AUX1"

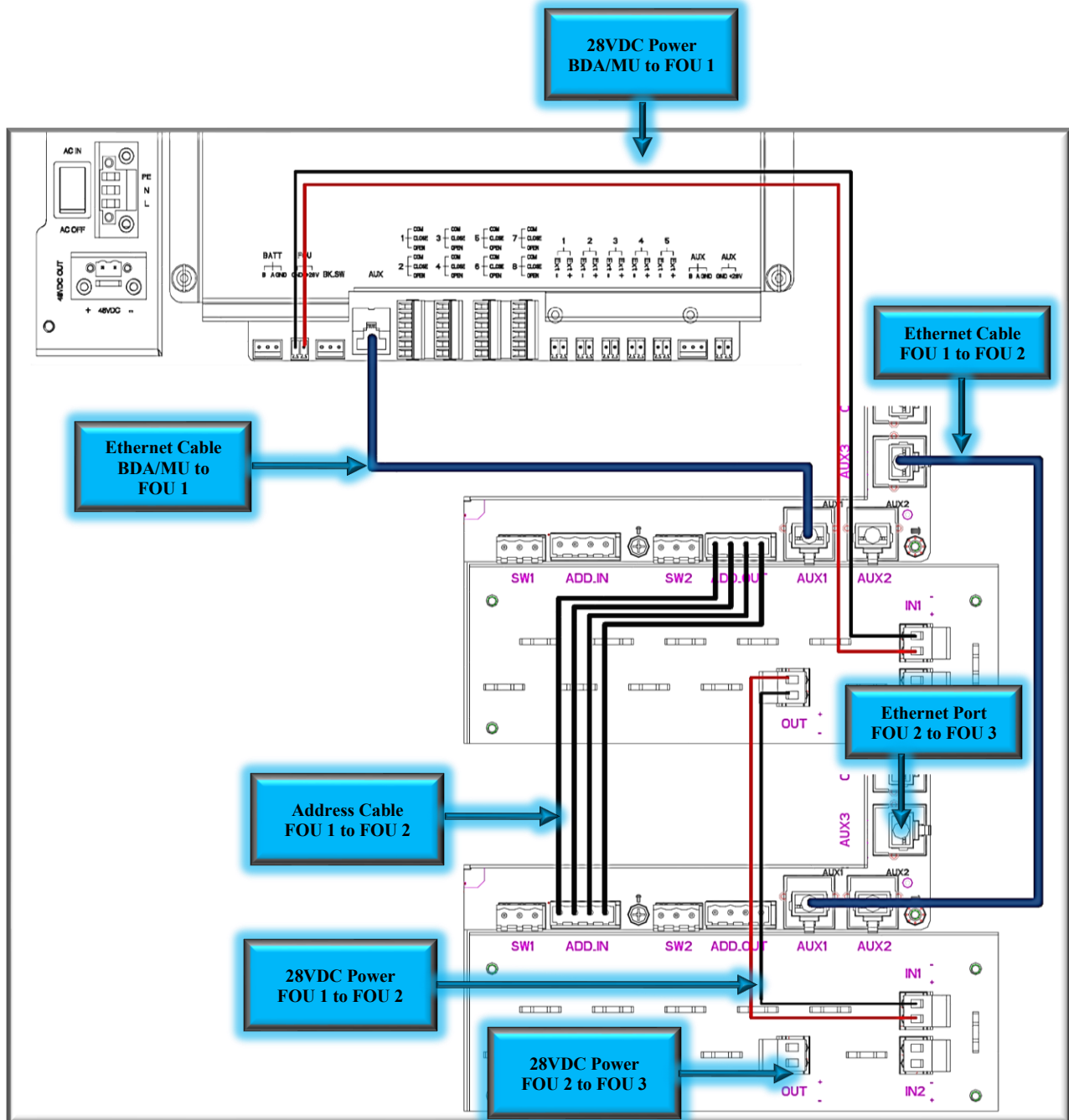

Figure 62: V3 BDA/MU and V2 FOU Power and Communications Wiring – Multiple FOU's



## 2.22 V3 RU OPTICAL FIBER CABLE GLAND ASSEMBLY

The V3 RU comes from the factory with an optical cable connector assembly which can be used to feed up to 2 optical fiber cables into the device.

Follow the instructions below to install an optical fiber using the provided optical cable gland assembly:

- Disassemble the optical cable gland assembly by pulling the clear inner-body out of the black outer-body.
- Remove the rubber cable grommet from the clear inner-body
- Run the optical fiber cable through the outer-body, rubber grommet, and inner-body.
- Reassemble the optical cable gland assembly
- Install in the RU by lining up threads and turning clockwise.

See Figure 64 below.

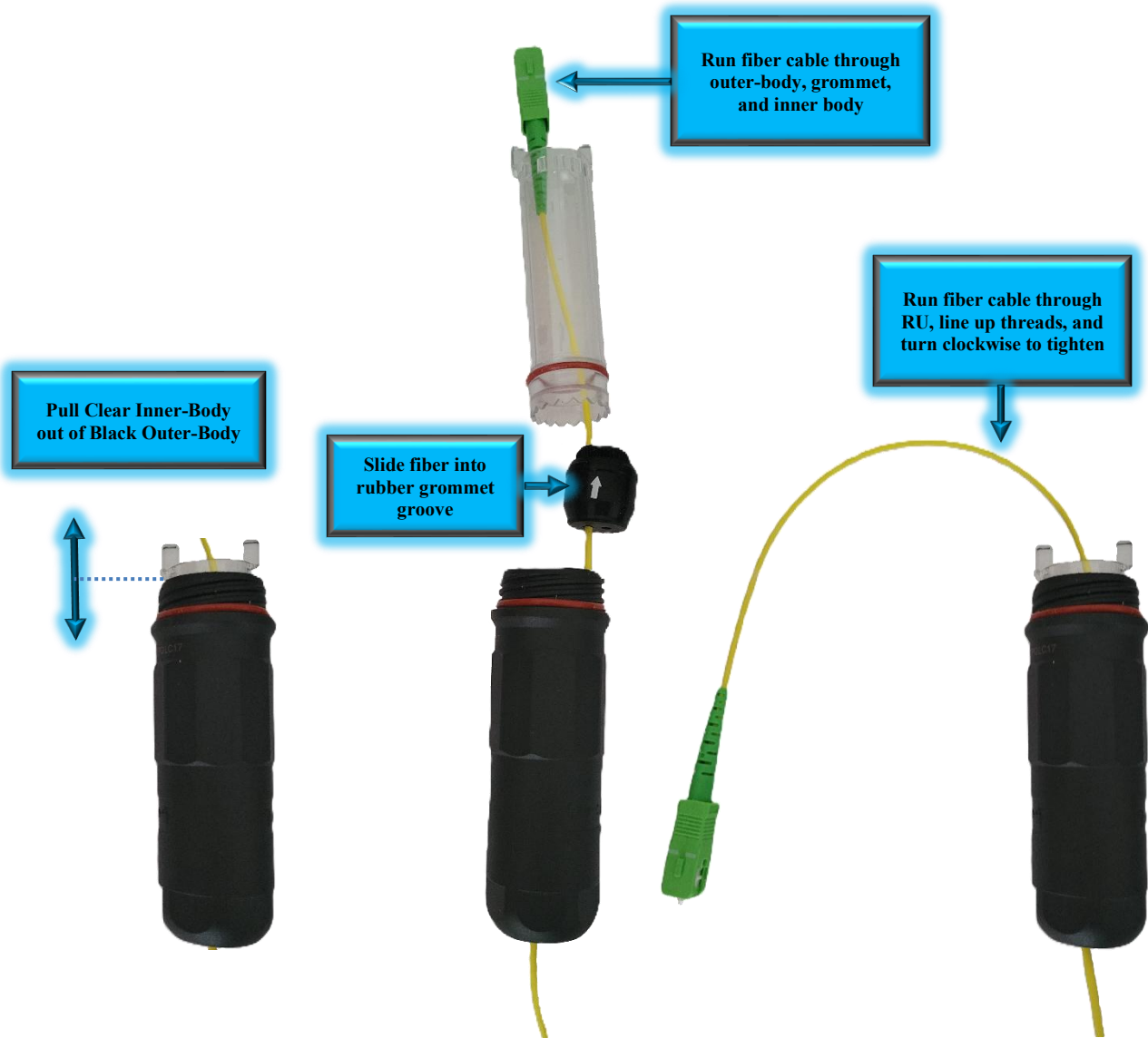

Figure 64: V3 RU Optical Fiber Cable Gland Assembly

## 2.23 SYSTEM RF CONNECTIONS

The following RF connections should be completed before powering on the devices:

Table 8: System RF Connections Before Power Up

RF Connector	Descriptions
BDA/MU DT Ports	Connect to the Donor Antenna feedline(s)
BDA/MU MT Ports	Connect to the Indoor Service Antenna feedline(s)
BDA/MU UL Port	Connect to the FOU UL 1 if used in a fiber DAS configuration
BDA/MU DL Port	Connect to the FOU DL 1 if used in a fiber DAS configuration
FOU UL 1	Connect to BDA/MU 1 UL Port if used in a fiber DAS configuration
FOU DL 1	Connect to BDA/MU 1 DL Port if used in a fiber DAS configuration
FOU UL 2	Connect to BDA/MU 2 UL Port if used in a fiber DAS configuration (Redundancy Feature)
FOU DL 2	Connect to BDA/MU 2 DL Port if used in a fiber DAS configuration (Redundancy Feature)
FOU UL_E	Connect to the next FOU UL 1 port if using expansion FOU(s)
FOU DL_E	Connect to the next FOU DL 1 port if using expansion FOU(s)
RU MT Port	Connect to the Indoor Service Antenna feedline



**ALERT! Disconnection of either of the RF ports (unloaded) may cause damage to the equipment when power and equipment is active.**

## 2.24 V1 AP ANNUNCIATOR PANEL INSTALLATION AND WIRING

The V3 BDA/MU or RU can be easily integrated with a Comba V1 AP Annunciator Panel. For complete instructions on how to install and commission the V1 AP with the V3 BDA/MU/RU, please refer to the V1 AP User Manual. V1 AP Dimensions, Installation, Wiring Details, and discovering the V1 AP in the software GUI are explained below. Further details are provided within the commissioning and alarms sections of this manual.

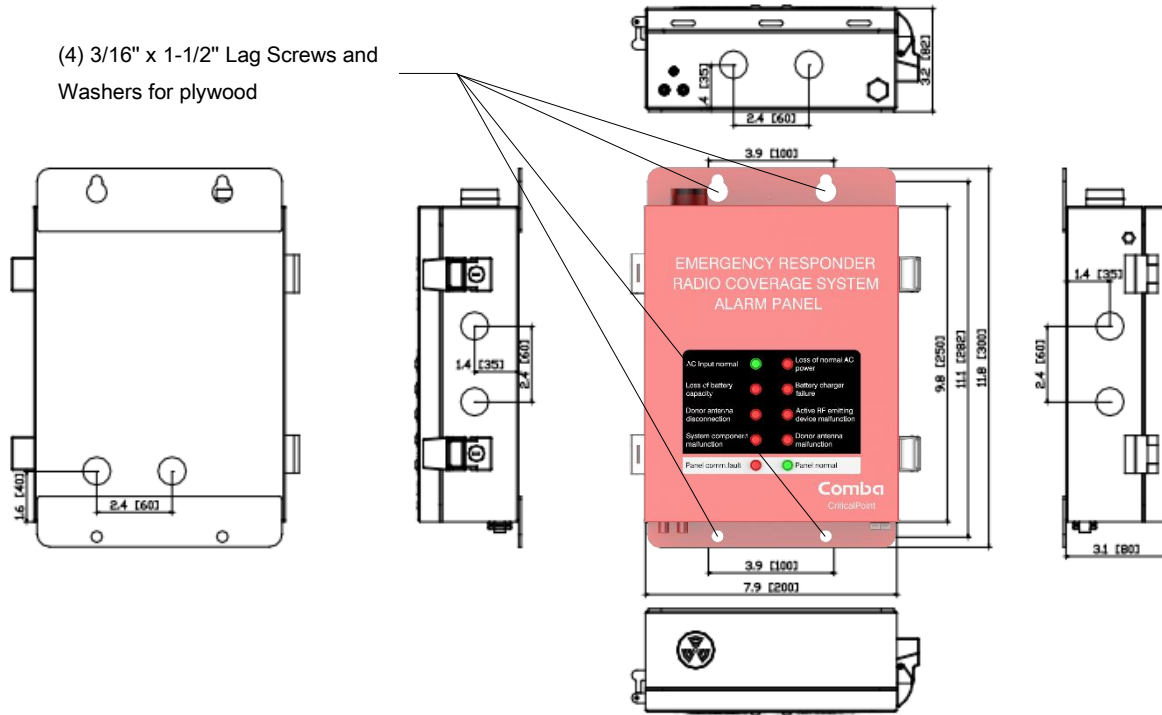

Figure 65: V1 AP Annunciator Cabinet Dimensions and Installation

Follow the instructions below to wall mount the V1 AP:

- Drill four holes on the wall/plywood using the position of four holes on the AP mounting bracket as a guide (AP mounting bracket is built into the AP cabinet).
- Install the AP cabinet on the wall. It is recommended to use 3/16" x 1-1/2" lag screws and fender washers when mounting to 3/4" fire treated plywood. If mounting to a concrete wall, DIN Rails, or any other materials, refer to the local building code. Secure the AP cabinet.

The V1 AP Power and Communications wiring is not provided with the equipment and must be provided by the installer. Follow the below instructions to connect the V1 AP to the V3 BDA/MU or RU:

- Power down the V3 BDA/MU or RU. Refer to Section 2.13 for the Power Off Switches.
- Ensure the V1 AP Power Switch is in the OFF position. See Figure 66 below.

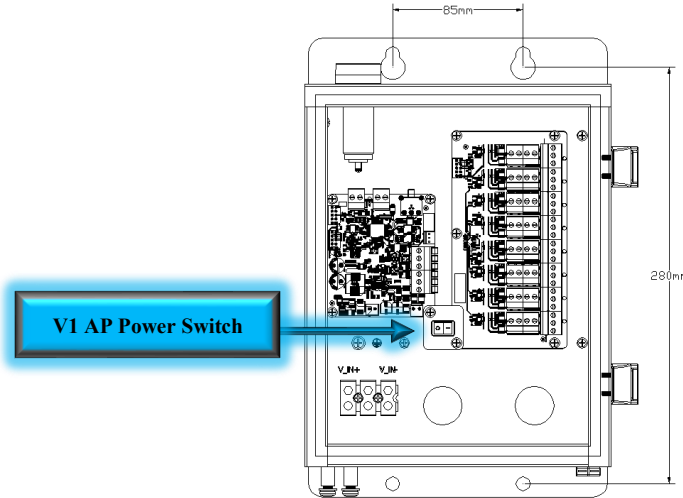

Figure 66: V1 AP Internal View and Power Switch

- Connect the 3 x RS485 wires between the BDA/MU/RU “AUX” (A, B, and GND) terminals to the V1 AP as shown below in Figure 67.
- Connect the +28VDC and -28VDC Power wires between BDA/MU/RU “AUX” (28VDC and GND) terminals to the V1 AP as shown below in Figure 67.

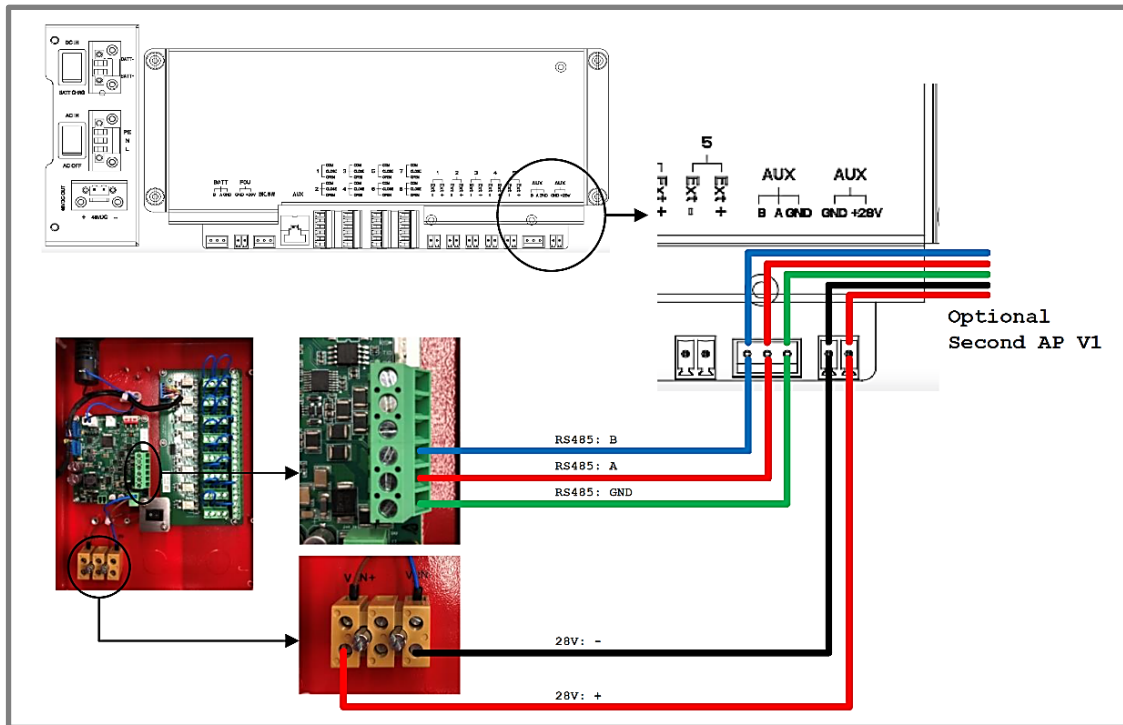

Figure 67: V3 BDA/MU and RU – AP V1 Connection

If only using one external V1 AP, the MCU Address Switch can be left in the default position. When using two V1 APs connected in parallel, you must adjust the Address Switch on the second V1 AP as described below.

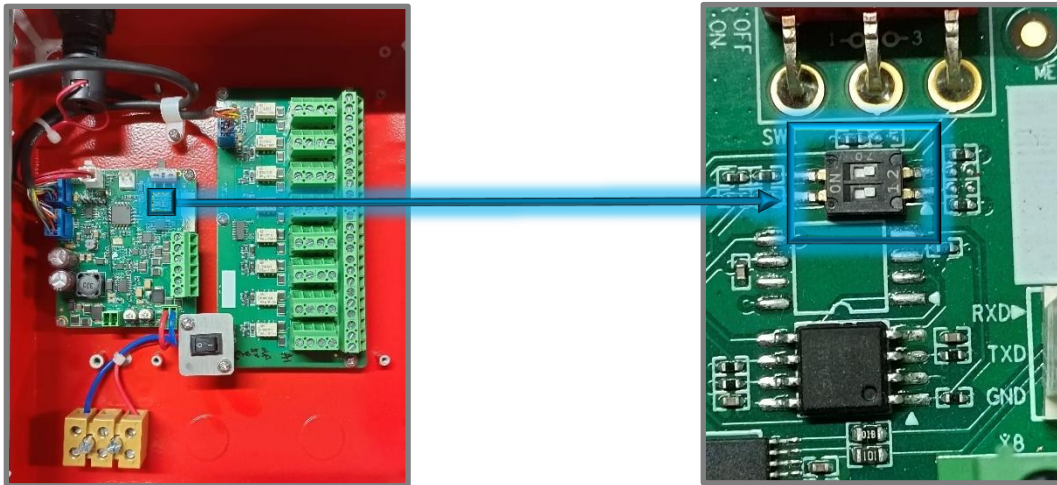
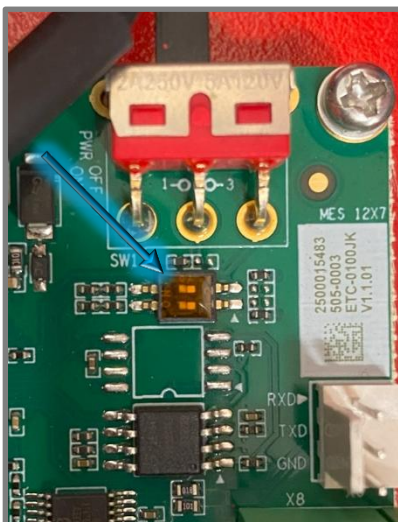

Figure 68: V1 AP MCU Address Setting Switch

When the BDA/MU/RU unit is connected to one external V1 AP, the address of the V1 AP is set to 1. When BDA/MU/RU unit is connected to two V1 APs, the address is set to 1 and 2, respectively.

Table 9: V1 AP Address Switch Setting

Switch Pin 1	Switch Pin 2	Address of V1 AP
OFF	OFF	1
OFF	ON	2



Remove the protective layer on the Dip Switch

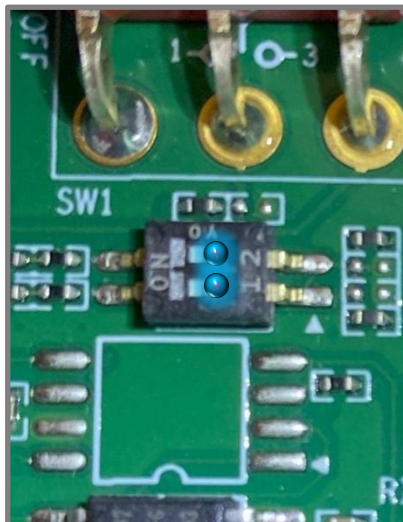

For the First AP:  
 DIP 1: OFF (Default)  
 DIP 2: OFF (Default)

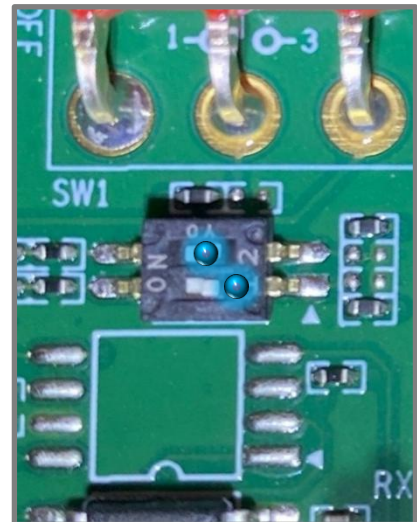

For the Second AP:  
 DIP 1: OFF  
 DIP 2: ON

Figure 69: RS485 Address Setting When Using Two V1 APs

## 2.25 V3 AP ANNUNCIATOR PANEL INSTALLATION AND WIRING

For complete instructions on how to install and commission the V3 APs with the V3 BDA/MU/RU, please refer to the V3 AP User Manual. V3 AP Dimensions, Installation, Wiring Details, and discovering the V3 AP in the software GUI are explained below. Further details are provided within the commissioning and alarms sections of this manual. See V2 BBU User Manual or Appendix G for details on connecting to V2 BBU.

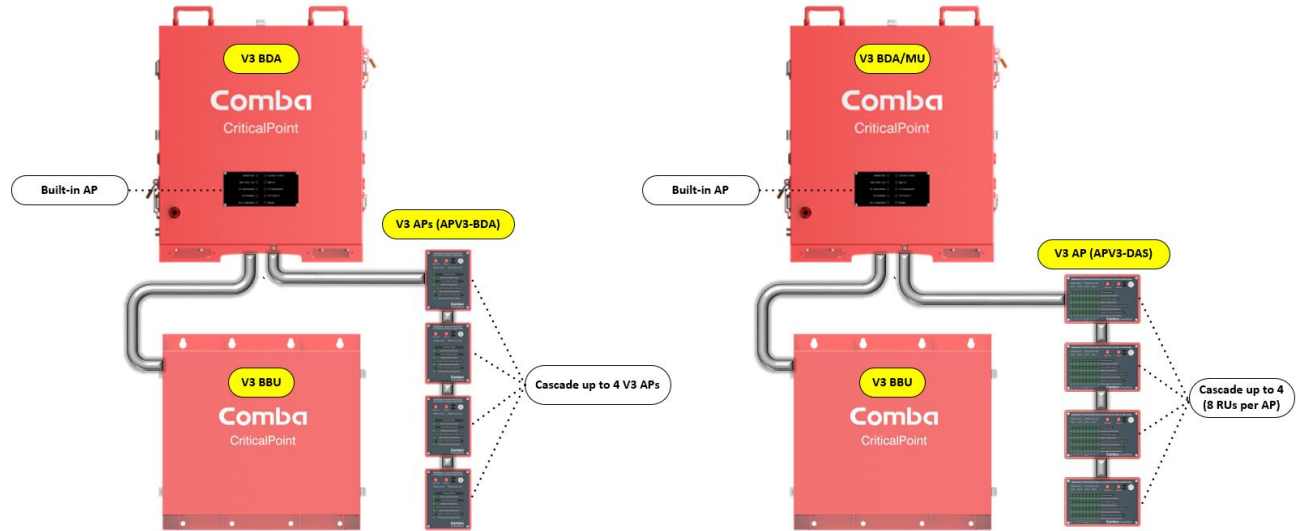

Figure 70: V3 Annunciator System Diagrams

There are (2) V3 annunciator models. APV3-BDA is for BDA and the APV3-DAS is for Fiber DAS systems with up to 32 remotes. Each model is provided with multiple front alarm plate options for the user to choose from. The V3 models are used for audible and visual annunciation of alarms only. They DO NOT provide any Dry-Contact Alarm Outputs to feed a fire alarm system. The V3 annunciators allow for standard wall mounting or flush mounting to a wall. A “Silence” and a “Lamp Test” button have been added to the exterior of the device. The provided key must be used to silence alarms or test the lamps/LEDs. The device uses RJ45 connectors for ease of installation using cat5/6 cable. The BDA/MU/RU devices are now provided with an adapter cable to be used to connect between the BDA/MU/RU AP terminals and a standard RJ45 ethernet cable.

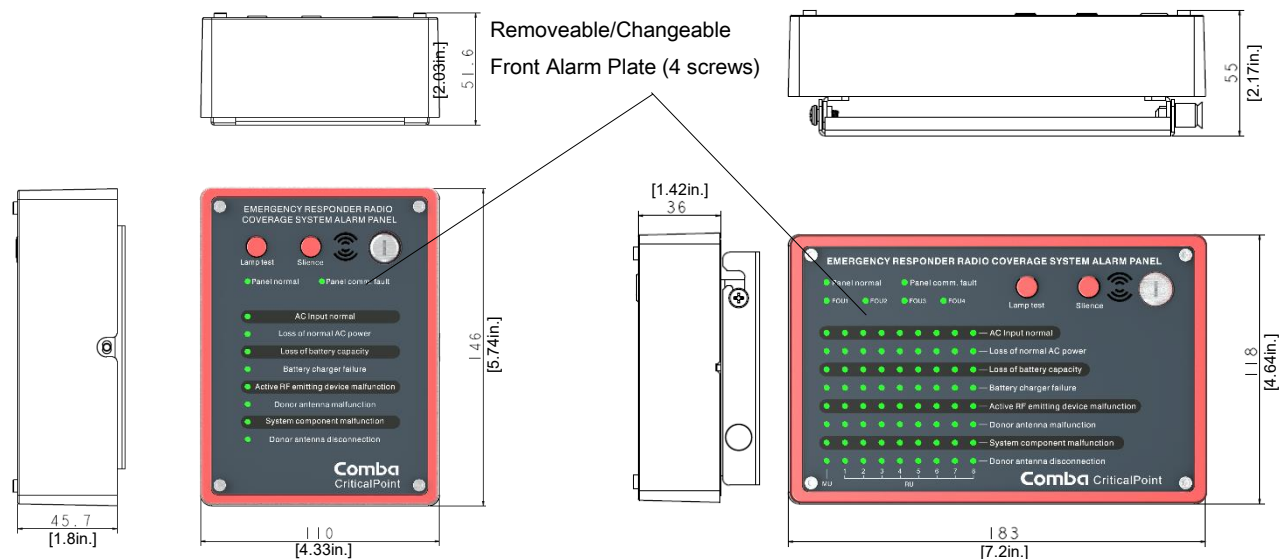

Figure 71: APV3-BDA Dimensions

Figure 72: APV3-DAS Dimensions

Follow the below instructions to mount the V3 AP to a 2-gang junction box. See Figures 73 and 74 below.

- Install the AP mounting bracket on the 2-gang junction box using the installation holes and corresponding (4) screws according to the specific junction box. Screws are not included.
- Run the ethernet RJ45 cable through the center of the mounting bracket and connect to the AP device.
- Align and hang the AP on the mounting bracket. For APV3-BDA, secure the AP to the bracket using the provided Hex screw. For APV3-DAS, secure the AP to the bracket using the provided spring pin lock.

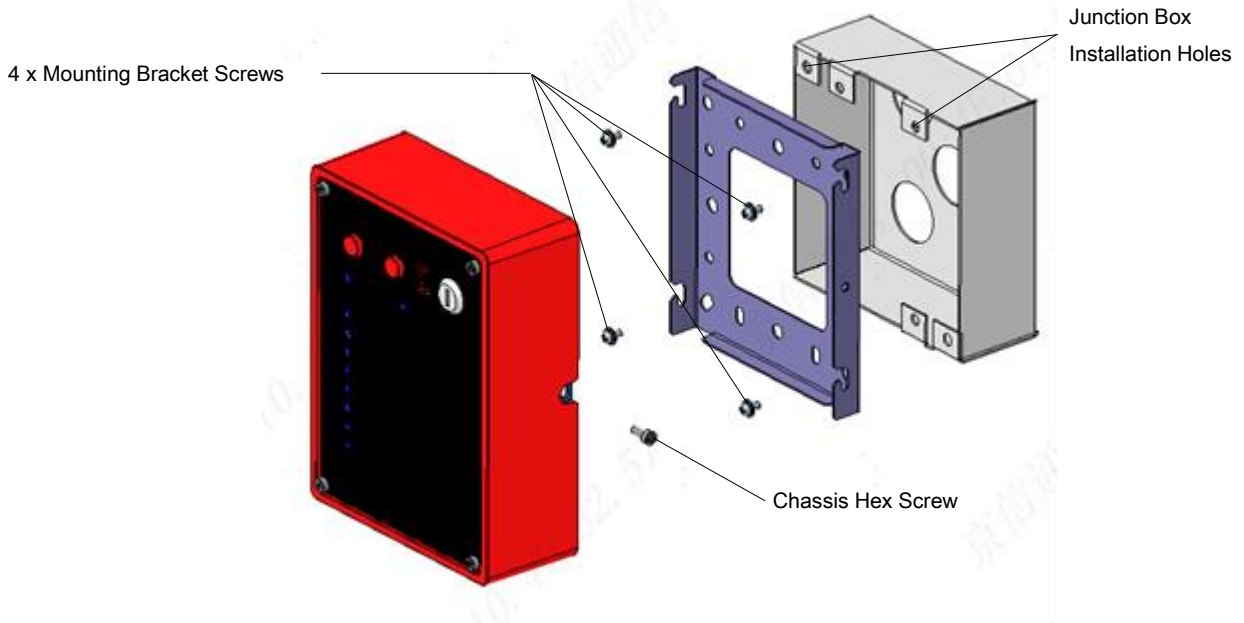

Figure 73: APV3-BDA – Mounting - Gang Box

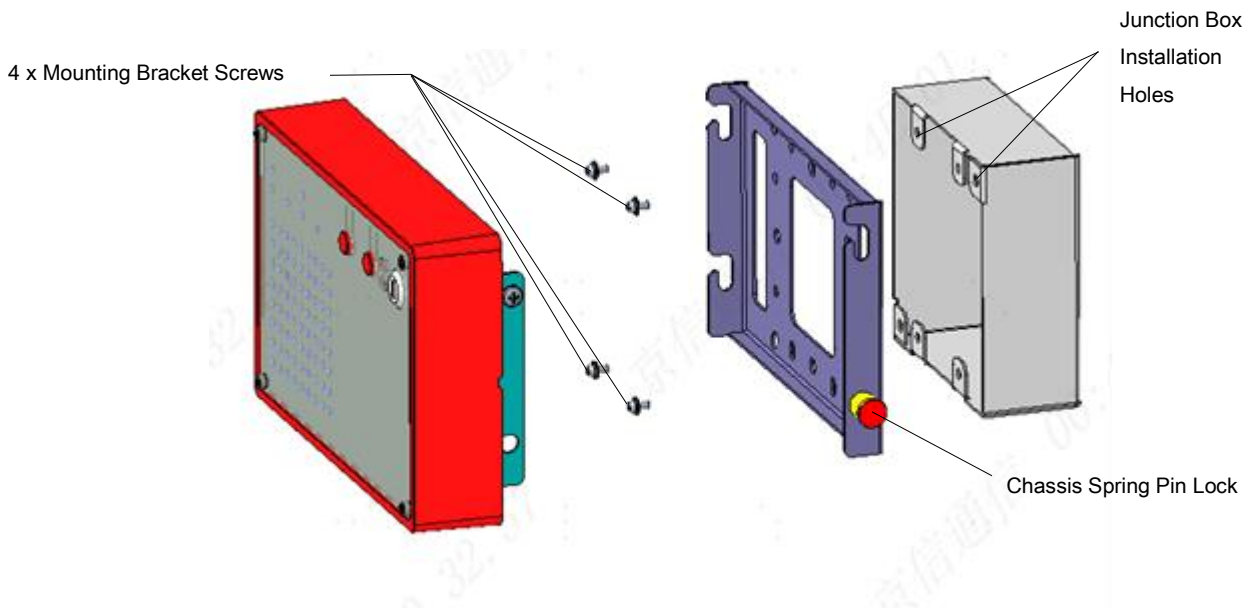

Figure 74: APV3-DAS - Mounting - Gang Box

Follow the instructions below and see Figures 75 through 79, to flush mount the APV3-BDA:

- Remove the APV3-BDA Flush Mount Kit from the box and place it on a flat surface with red face plate facing up.
- Remove the (4) Philips head screws holding the faceplate to the mounting bracket. Do not discard screws as these will be used to reinstall the face plate. Remove the face plate.
- Remove the (4) screws that are attached to the mounting bracket from the factory. These screws will be used in the next step to attach the APV3-BDA standard mounting bracket to the flush mount bracket. See Figure 75 below.

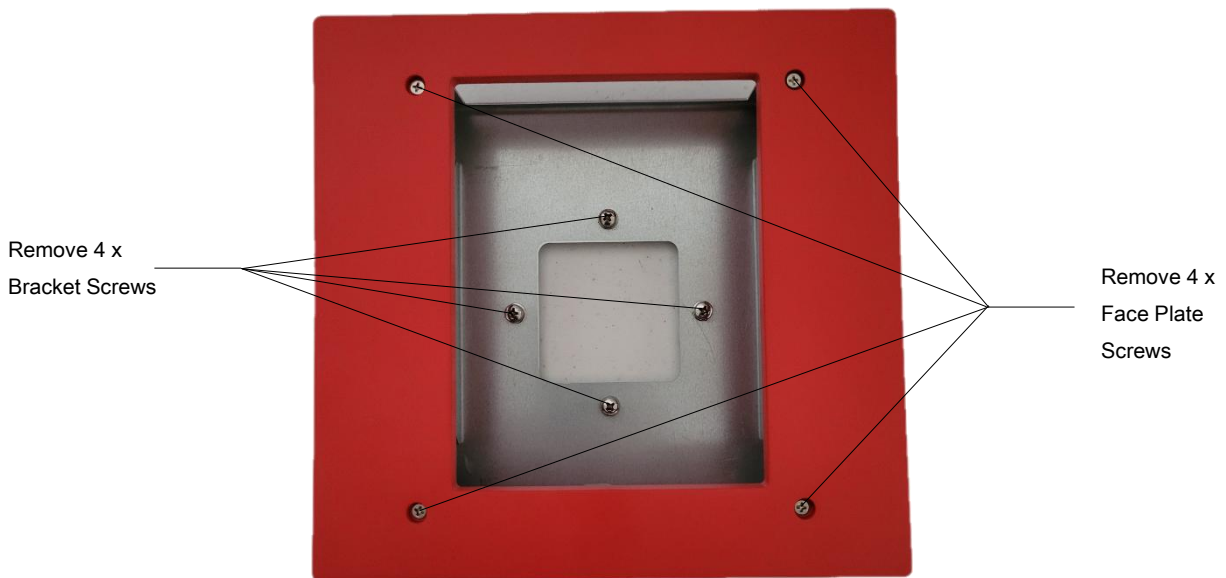

Figure 75: APV3-BDA - Flush Mount Kit Face Plate and Bracket Screw Removal

- Install the APV3-BDA standard mounting bracket into the flush mount bracket using the (4) screws removed in the previous step. Ensure the standard mounting bracket is installed with the HEX Screw hole on the right side. See Figure 76 below.

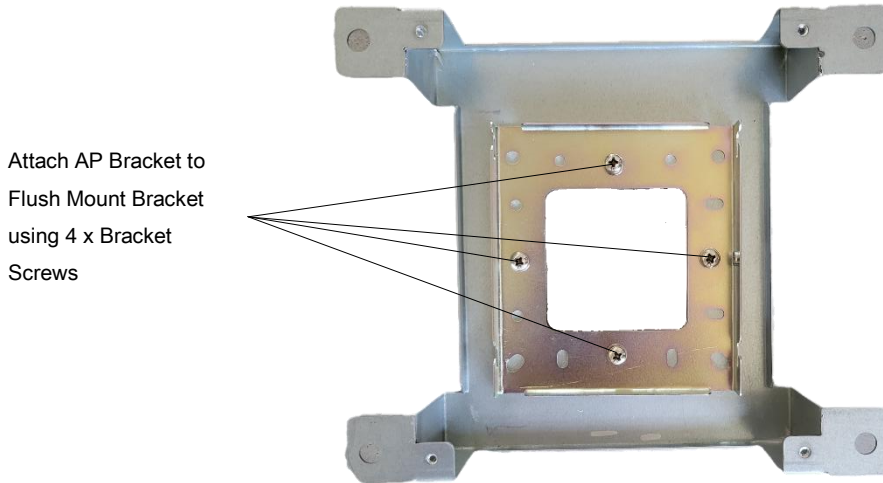

Figure 76: APV3-BDA - Mounting Standard Mounting Bracket to Flush Mount Bracket

- Align and hang the APV3-BDA cabinet onto the flush mounting bracket. Note, the Hex Screw that was removed earlier to release the standard mounting bracket from the AP is not used when flush mounting the APV3-BDA. You can simply hang the device onto the flush mount assembly. Refer to Figure 77 below.



Figure 77: APV3-BDA - Mounting APV3-BDA into Flush Mount Bracket

- Using the AP flush mounting bracket as a template, hold the bracket against the wall in the planned installation location. Using a pencil, trace the sides of the bracket to mark the rectangular location on the wall that needs to be cut out. Using a saw, cut out the rectangular section of drywall and remove.
- Push the AP mounting bracket into the rectangular area of removed drywall, so it fits flush and tight into the wall. If the rectangular area is too small to push the bracket into position, you may need to use sandpaper or another tool to slightly enlarge the rectangular opening.
- Once the AP and Flush Mount Bracket are in position, use a pencil to mark the location of the 4 holes that will need to be drilled to secure the flush mount bracket to the wall. After hole locations are marked, remove the AP and flush mount bracket from the wall.
- Drill four holes into the drywall using the previously marked locations. Install wall anchors as necessary.
- Connect the RJ45 ethernet cable to the V3 AP “PREV” port through the flush mount bracket.
- Push AP and flush mount bracket into the wall location.
- Use (4) screws to attach the flush mounting bracket to the wall. Screws and anchors are not provided.
- Install the flush mount front plate using the (4) provided screws.

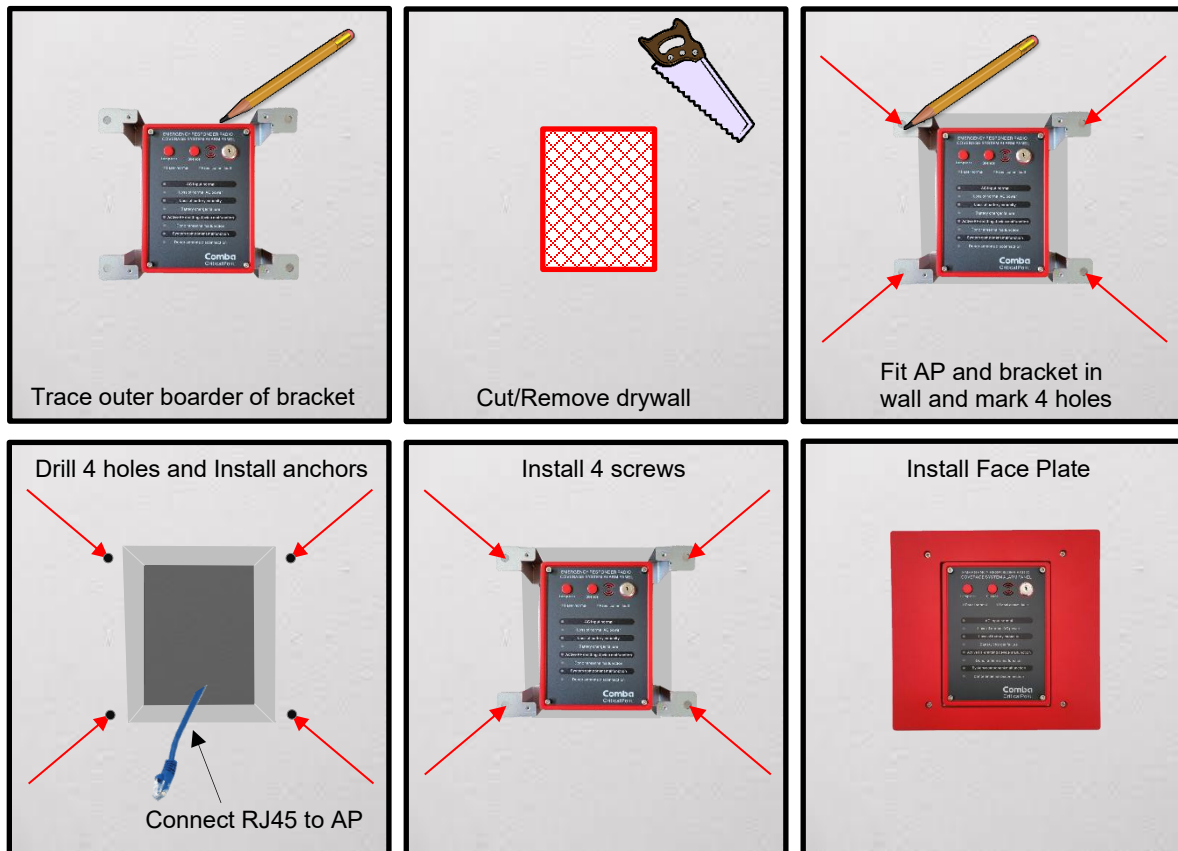

Figure 78: APV3-BDA - Installing Flush Mount Bracket, APV3-BDA, and Face Plate into a Wall

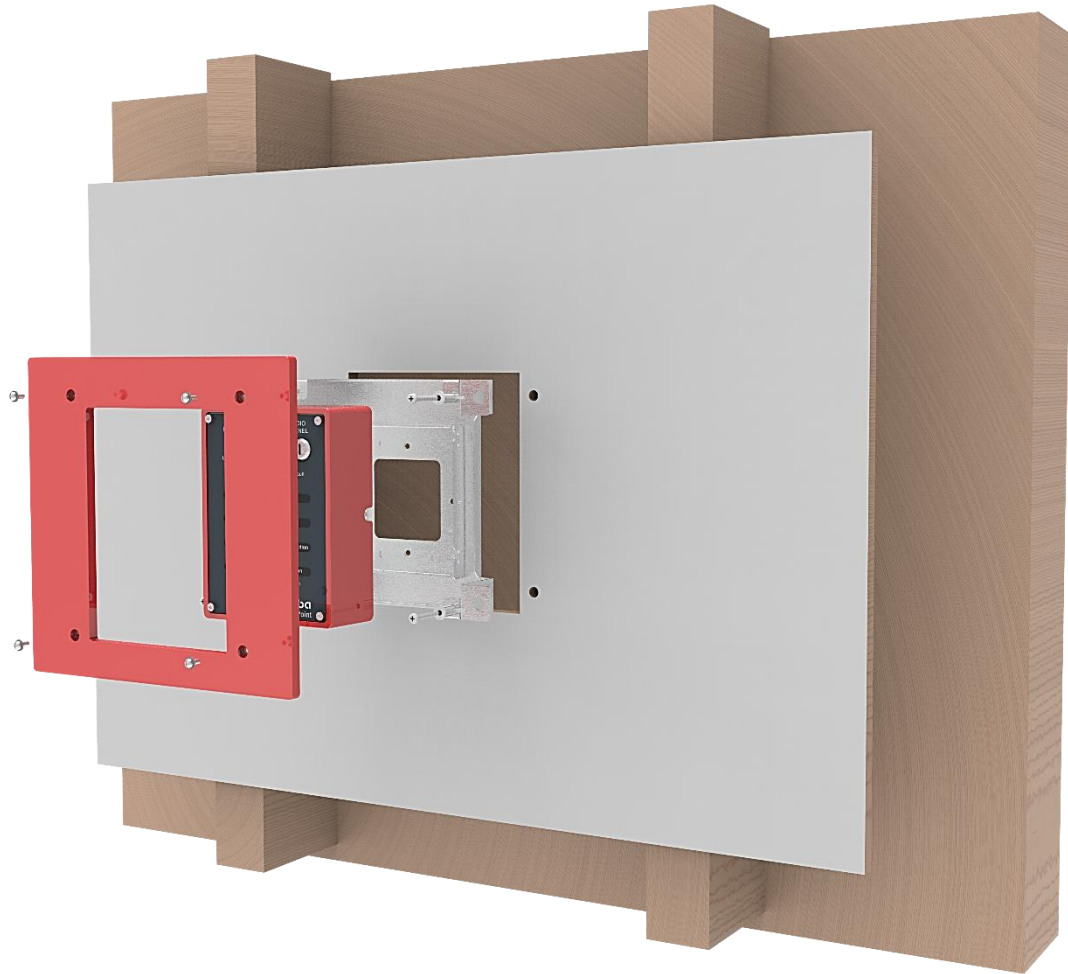

Figure 79: APV3-BDA - Flush Mounting to Wall

Follow the below instructions and see Figures 80 through 84, to flush mount the APV3-DAS:

- Remove the APV3-DAS Flush Mount Kit from the box and place it on a flat surface with red face plate facing up.
- Remove the (4) Philips head screws holding the faceplate to the mounting bracket. Do not discard screws as these will be used to reinstall the face plate. Remove the face plate.
- Remove the (4) screws that are attached to the mounting bracket from the factory. These screws will be used in the next step to attach the APV3-DAS standard mounting bracket to the flush mount bracket. See Figure 80 below.

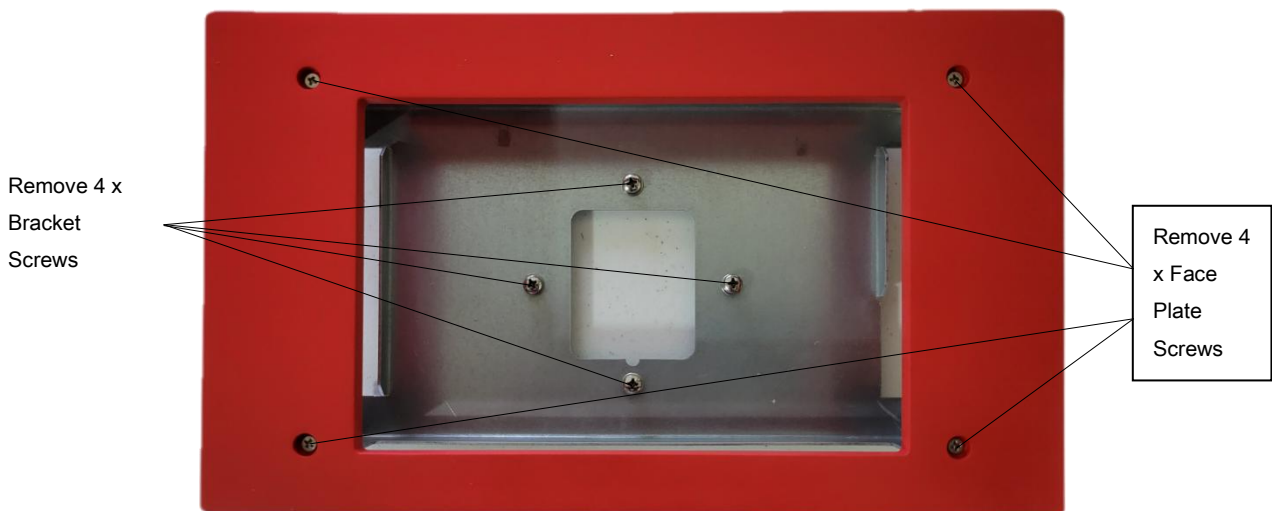

Figure 80: APV3-DAS - Flush Mount Kit Face Plate and Bracket Screw Removal

- Install the APV3-DAS standard mounting bracket into the flush mount bracket using the (4) screws removed in the previous step. Ensure the standard mounting bracket is installed with the Spring-loaded Pin Lock on the right side. See Figure 81 below.

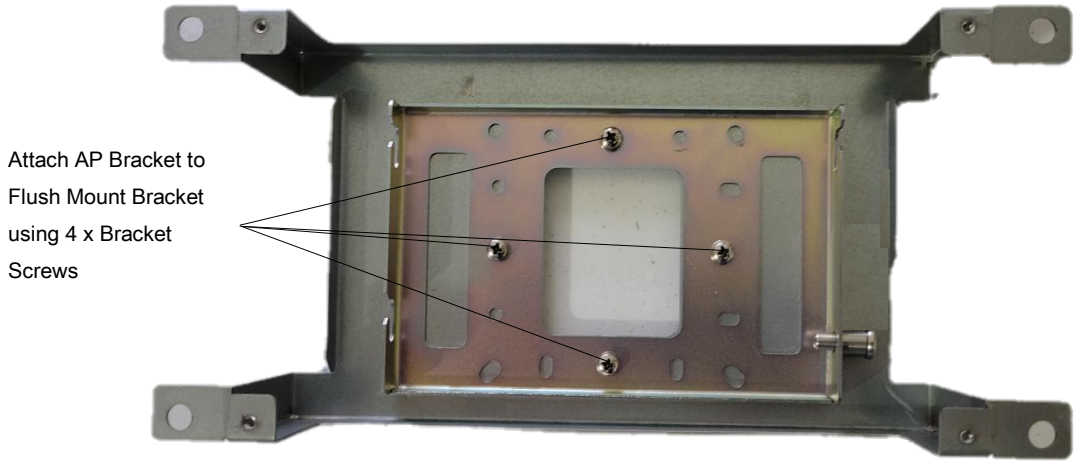

Figure 81: APV3-DAS - Mounting Standard Mounting Bracket to Flush Mount Bracket

- Align and hang the APV3-DAS cabinet onto the flush mounting bracket. You must pull out the spring-loaded pin lock, hang the AP cabinet, then release the pin lock.



Figure 82: APV3-DAS - Mounting APV3-DAS into Flush Mount Bracket

- Using the AP flush mounting bracket as a template, hold the bracket against the wall in the planned installation location. Using a pencil, trace the sides of the bracket to mark the rectangular location on the wall that needs to be cut out. Using a saw, cut out the rectangular section of drywall and remove.
- Push the AP mounting bracket into the rectangular area of removed drywall, so it fits flush and tight into the wall. If the rectangular area is too small to push the bracket into position, you may need to use sandpaper or another tool to slightly enlarge the rectangular opening.
- Once the AP and Flush Mount Bracket are in position, use a pencil to mark the location of the 4 holes that will need to be drilled to secure the flush mount bracket to the wall. After hole locations are marked, remove the AP and flush mount bracket from the wall.
- Drill four holes into the drywall using the previously marked locations. Install wall anchors as necessary.
- Connect the RJ45 ethernet cable to the AP "PREV" port through the flush mount bracket.
- Push AP and flush mount bracket into the wall location.
- Use (4) screws to attach the flush mounting bracket to the wall. Screws and anchors are not provided.
- Install the flush mount front plate using the (4) provided screws.

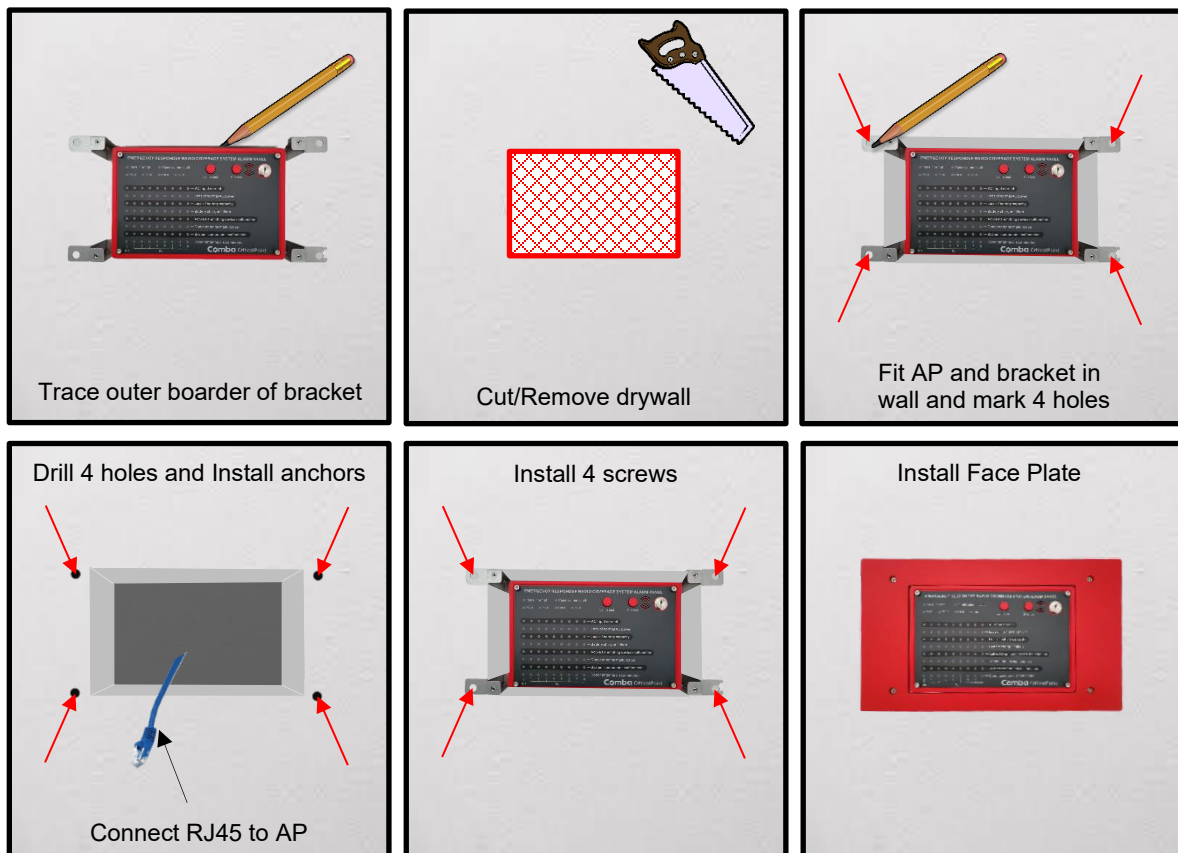

Figure 83: APV3-BDA - Installing Flush Mount Bracket, APV3-BDA, and Face Plate into a Wall

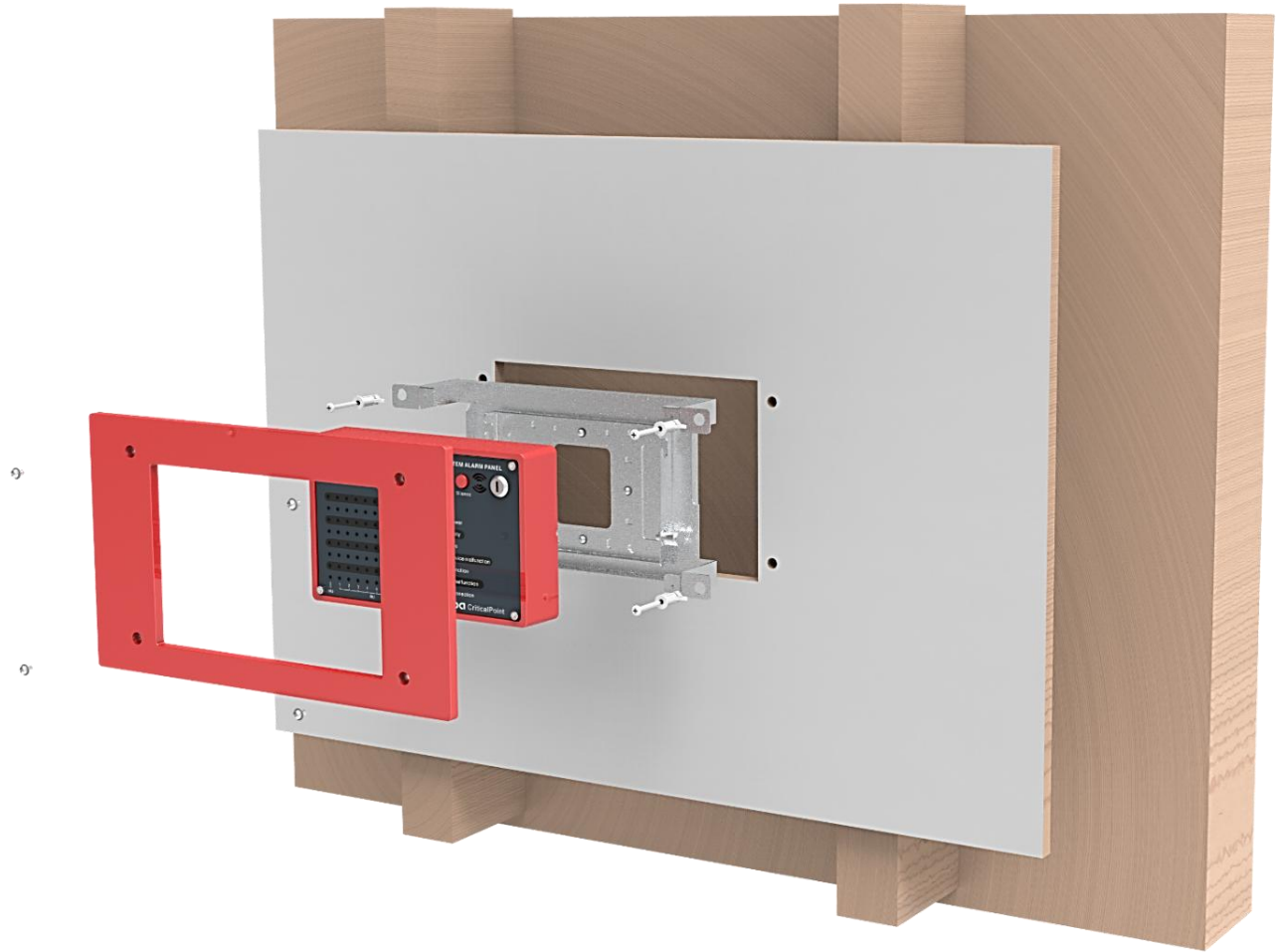

Figure 84: APV3-DAS - Flush Mounting to Wall

The V3 AP Power and Communications wiring is not provided with the equipment and must be provided by the installer. The BDA/MU/RU connects to the V3 AP using T568B RJ45 network cable sequence. An adapter cable is provided to combine the BDA/MU/RU Power and Comms Outputs into an RJ45 female connector. This allows for a single run of cat 5/6 cable terminated with RJ45 connectors to be used in between the BDA/MU/RU and V3 APs. This adapter cable comes pre-terminated from the factory with phoenix connectors allowing for quick installation. See Figure 85 below.



**ALERT: DO NOT use an ethernet crossover cable to connect between the BDA/MU/RU and V3 AP devices. The crossover cable DOES NOT support the power and RS-485 sequence and WILL cause damage to the devices.**

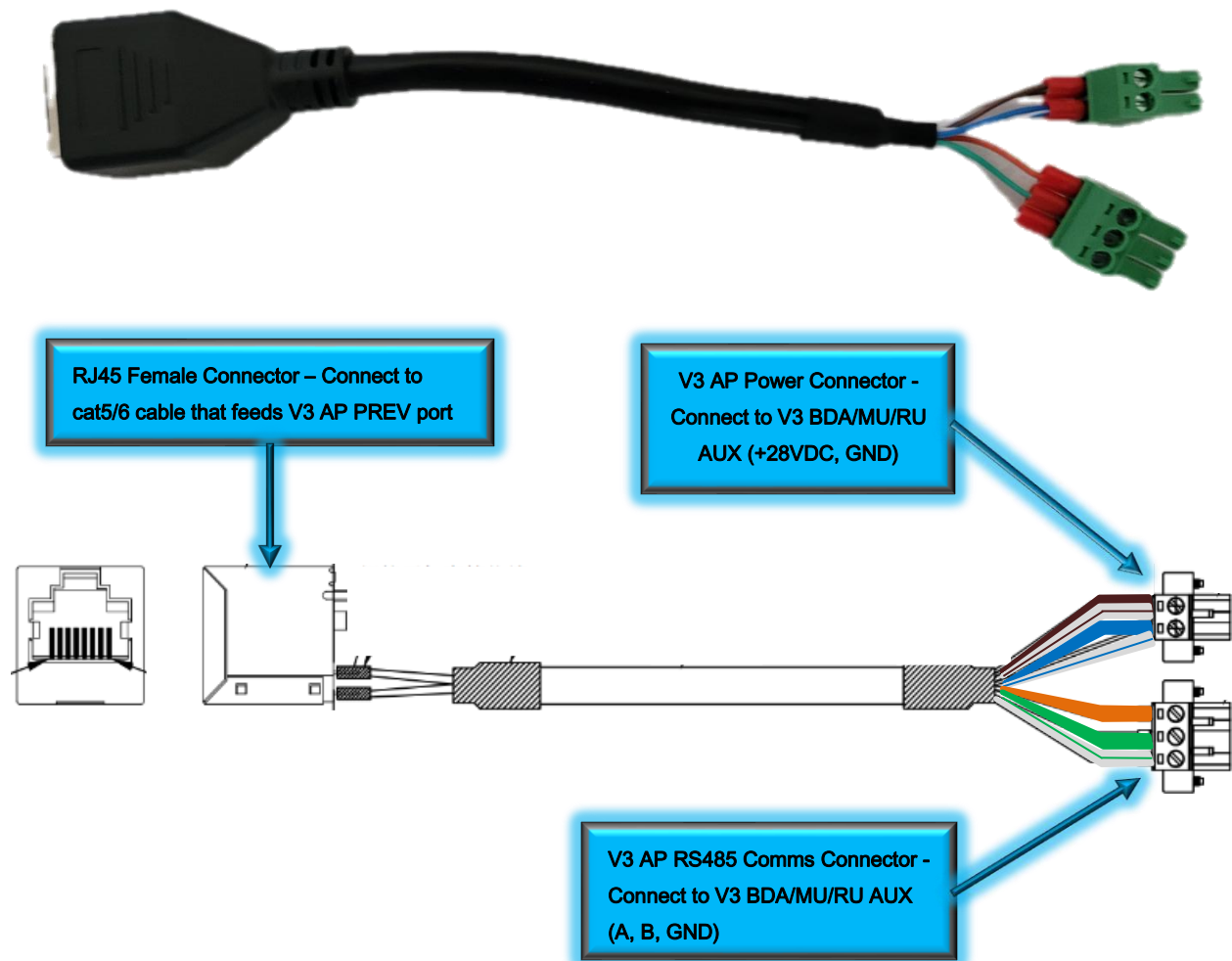

Figure 85: V3 BDA/MU/RU - RJ45 Adapter for V3 APs

Follow the instructions below and see Figure 86 below, to connect a V3 AP to the V3 BDA/MU or RU:

- Power down the V3 BDA/MU or RU system.
- Connect the RJ45 adapter to the BDA/MU/RU as shown in Figure 86 below.
- Connect RJ45 ethernet cable between the RJ45 adapter and the V3 AP “PREV” port.
- To cascade additional APs, connect RJ45 cat5/6 cable between previous AP1 “NEXT” port and AP2 “PREV” port.

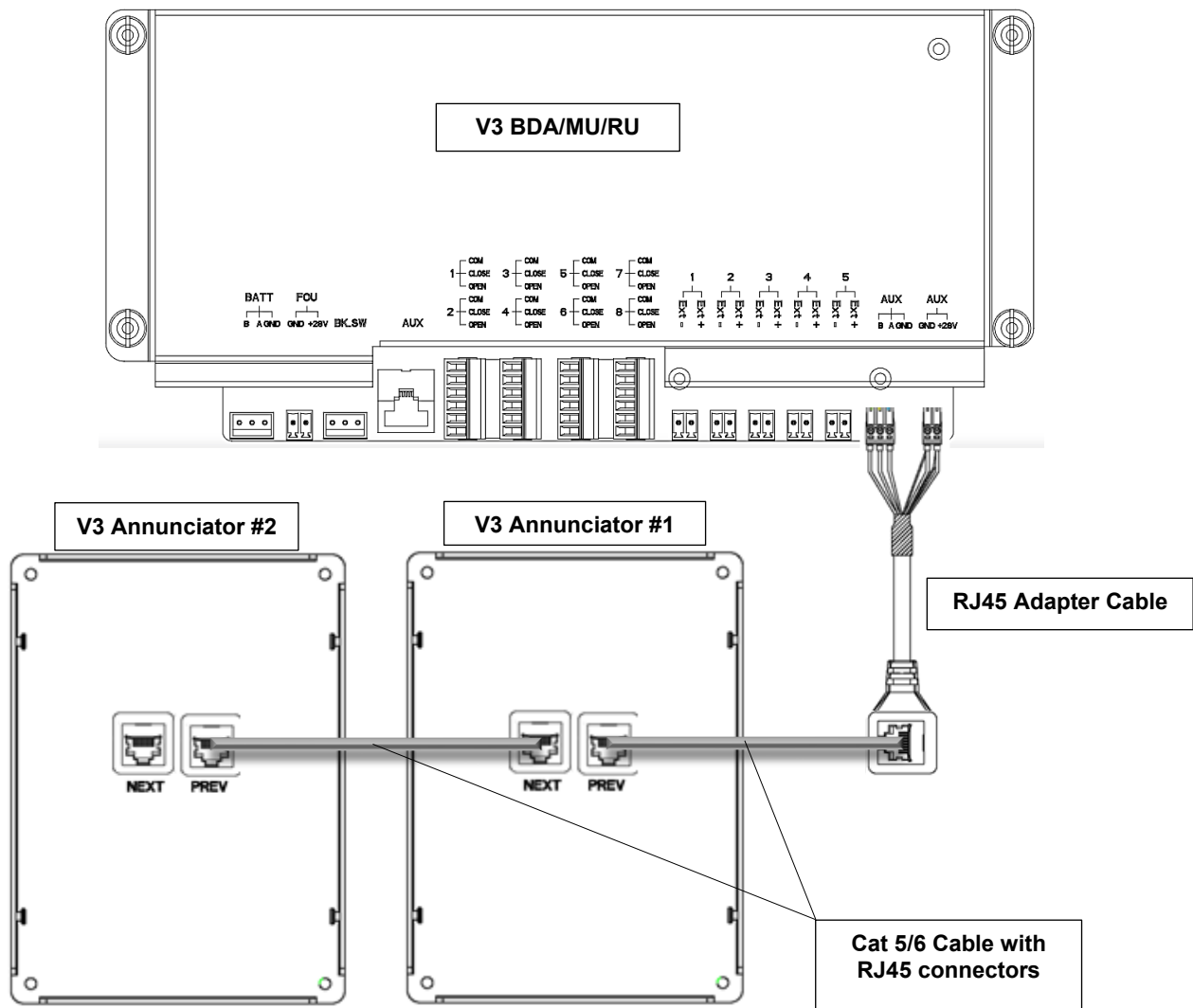

Figure 86: V3 BDA/MU/RU Wiring Connection to V3 AP



**Caution:** You must follow your local code requirements for guidance on cable installation. See local codes for additional guidance on installing cabling inside of conduit as well as free wiring cable. Please ensure the correct liquid tight connector or cable gland is used.

When using multiple APs in cascade or parallel from a BDA/MU/RU device, each AP must be addressed so they can communicate properly with the BDA/MU/RU over RS485 protocol. A 4-position DIP Switch is located on the internal PCB board and is used to set the address. When BDA/MU/RU is connected to one AP, the address of the AP is set to 1. This is also the default address set from the factory. When two APs are connected, the addresses are set to 1 and 2. A maximum of two APs can be connected in parallel. When APs are being connected in cascade/series, each AP must be addressed according to its position in the chain, with the 1<sup>st</sup> AP addressed as 1, and the 4<sup>th</sup> AP addressed as 4(MAX of 4 in cascade). The display of FOU1~FOU4 in APV3-DAS is associated with the address of the alarm panel. For example, when both DIP Switches are in the ON position, the address of the alarm panel is 4, and the FOU4 light for that APV3-DAS will illuminate, indicating that the panel displays an alarm for RUs connected to FOU4. Refer to Figure 87 and Table 10 below.

Use the below instructions to change the address of a V3 AP **BEFORE** installing:

- Lay the V3 AP down on its face. Remove the mounting bracket if it is attached.
- Remove the (4) Philips head screws holding the backplate in place. Remove the backplate.
- Change the address on the DIP switch accordingly. Refer to the following table for guidance.
- Reinstall the backplate.

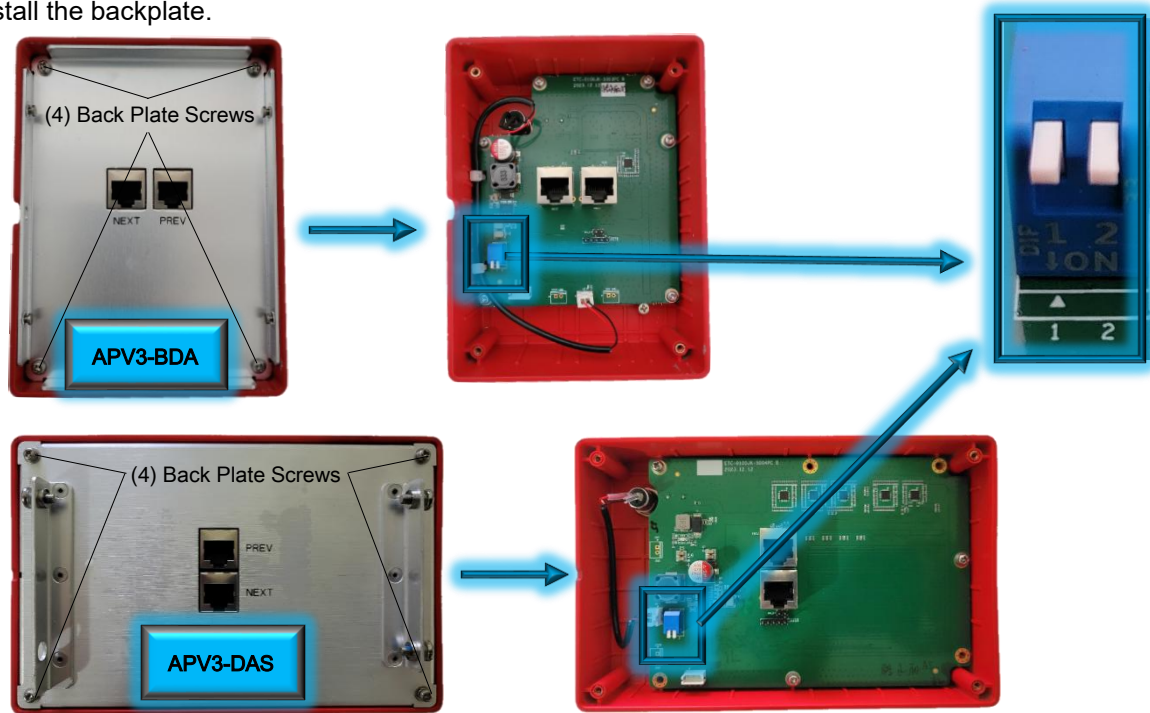

Figure 87: V3 AP - Address Switch Setting

Table 10: V3 AP - Address Switch Setting

Switch Pin 1	Switch Pin 2	Address of Alarm panel
OFF	OFF	1 (Default)
ON	OFF	2
OFF	ON	3
ON	ON	4

End of Section

### 3 COMMISSIONING

This section is NOT a guide for the full commissioning procedure! System commissioning can be performed by the user in many different manners. It is up to the technician who has all the project details to decide in which order and what steps to commission the BDA system per the project requirements. The following sections provide an overview of the steps Comba recommends taking when commissioning the system. Some steps may be skipped or omitted if they do not apply to your application.

It is also important that the technician commissioning the system is an authorized operator. Please refer to Section 0.12 for more details on who is authorized to operate the equipment.

Signal Boosters/Zone Enhancers (Also referred to BDAs or Fiber Fed BDAs) are not consumer devices. They are industrial devices which may only be operated and maintained by authorized individuals and qualified installers.

1. Operators of the equipment MUST have taken and passed Comba Telecom's certification training for RF101 and the V3 BDA/DAS/BBU product line.
2. Operators of the equipment MUST have a valid FCC General Radio Operator License (GROL) if operating the device in the USA.
3. Operators of the equipment MUST have NICET Level 3 Certification IB-PSC; or they MUST have NICET Level 2 Certification IB-PSC and be supervised by someone who has NICET Level 3 IB-PSC if operating the device in the USA.
4. Installers of the equipment MUST have NICET Level 2 Certification IB-PSC or higher; or they MUST have NICET Level 1 Certification IB-PSC and be supervised by someone with NICET Level 2 Certification IB-PSC or higher while operating the device in the USA.
5. Non-Licensee Operators MUST receive express written consent to operate the Signal Booster/Zone Enhancer from the FCC/ISED License Holder BEFORE installing and operating the device.

#### 3.1 PRE-COMMISSIONING TASKS

After equipment installation, perform the following steps before equipment power up and commissioning:

- Verify that the expected voltage, current and power levels do not violate any ratings.
- Visually inspect all power and communications wiring connections within the equipment. Ensure that all cables are correctly and securely connected including the AC and DC power wires, grounding wire, RF cables and other cables.
- Check the grounding connection and verify that the ground resistance is less than 5Ω.
- Evaluate the antenna system and ensure that the system return loss within working frequency is less than -14dB (VSWR<1.5).
- Ensure all RF connections are completed or terminated with loads. See Section 2.23 for more details.
- Gather the required RF inputs for system commissioning. See Section 3.2

### 3.2 REQUIRED RF INPUTS FOR COMMISSIONING

Users are encouraged to gather the information below before commissioning the system. See Table 11 below which provides an explanation of the recommended inputs which should be gathered and their purpose in commissioning the system.

Table 11: Required RF Inputs for Commissioning

RF Inputs	Description/Notes
Donor Site TX ERP (dBm)	<p><b>Provided by AHJ and/or FCC/ISED License Holder.</b> The Effective Radiated Power of each channel from the Donor Site. <b>Example:</b> 100 Watts / 50dBm per Radio Channel</p> <p>Used in calculations to estimate the DL Channel Input Power and DL and UL pathloss between the donor site and BDA.</p>
Donor Site TX/RX Delta (dB)	<p><b>Provided by AHJ and/or FCC/ISED License Holder.</b> The difference in donor pathloss between the DL and UL paths; due to RF Gain components on the donor site receive side such as RX Antennas, Tower Top Amplifiers, and RX Multi-couplers. <b>Example:</b> Donor Site TX/RX Delta is -15dB due to an additional 15dB of Gain provided by RF components on the receiver side.</p> <p>Used in calculations to estimate the total UL pathloss between the BDA and donor site.</p>
Donor Site RX RSSI (dBm) (Maximum and Minimum)	<p><b>Provided by AHJ and/or FCC/ISED License Holder.</b> The required RSSI Range at Donor Site (Minimum and Maximum).</p> <p>If only a minimum is provided, you can use the same number for the minimum and maximum. <b>Example:</b> &gt;-95dBm is required. MAX RSSI = -95dBm MIN RSSI = -95dBm</p> <p>Used in calculations to estimate the UL Channel Target Power and UL MAX Gain.</p>
BDA Donor Antenna Gain (dBd)	<p><b>Refer to Datasheet of Installed Donor Antenna.</b> The Gain of the Donor Antenna expressed in dBd. <b>Example:</b>12dBd / 14.15dBi</p> <p>Used in calculations to estimate the DL and UL pathloss between the donor site and BDA input.</p>
BDA Donor Cable Loss (dB)	<p><b>Provided by the System Design or Manual Measurement</b> The total passive loss between the Donor Antenna and BDA Donor Terminal; due to passive components such as cables and surge arrestors.</p> <p><b>Example:</b> ½ in Donor Cable Length: 100ft (2.2dB/100ft) Surge Arrestor Insertion Loss: 0.2dB Donor Cable Loss = 2.2dB + 0.2dB = 2.4dB</p> <p>Used in calculations to estimate the DL and UL pathloss between the donor site and BDA.</p>

<p>Distance (Mi) to Donor Site</p>	<p><b>Provided by the System Design or Manual Measurement</b> The distance in miles between the donor site and BDA Donor Antenna. <b>Example:</b> 1 mile / 95.19dB</p> <p>Used in calculations to estimate the DL and UL Free Space pathloss between the donor site and BDA.</p>
<p>Manual Antenna Isolation Measurement</p>	<p><b>Provided by RF technician manual measurement</b> The isolation between the donor antenna and indoor antenna branches. <b>Example:</b> 120dB isolation</p> <p>Used to determine the DL/UL MAX Gain of the BDA. Follows the code requirement to provide 20dB margin between Gain and Isolation.</p>
<p>Manual DL Channel Input Measurement</p>	<p><b>Provided by RF technician manual measurement</b> The Channel Power received from the donor antenna measured at the donor input of the BDA. <b>Example:</b> Control Channel Power measured at -50dBm</p> <p>Used in calculations to estimate the DL MAX Gain.</p>
<p>Manual DL Composite Input Measurement</p>	<p><b>Provided by RF technician manual measurement</b> The Total Average Composite Power from the donor antenna measured at the donor input of BDA. <b>Example:</b> Average DL Composite Power across passband measured at -40dBm using MAX Hold feature for 10 minutes</p> <p>Used to determine if the DL Input Power will be too high and require attenuation.</p>
<p>Manual UL Input Range Measurement (Maximum and Minimum)</p>	<p><b>Provided by RF technician manual measurement</b> The range of Input Signal Level that will be seen at the BDA mobile input from portable radios within the coverage area. <b>Example:</b> Maximum: -30dBm received from Near radio Minimum: -70dBm received from Far radio</p> <p>Used in calculations to estimate the UL MAX Gain.</p>
<p>Inbuilding and Building Perimeter Benchmark Testing</p>	<p><b>Provided by RF technician manual measurement</b> The preliminary building RF coverage results before the BDA system is turned ON. <b>Example:</b> Grid Test results from preliminary walk test</p> <p>Used for coverage dominance tuning. Inside the building, the indoor signal should dominate the macro signal. Around the outside perimeter of the building, the macro signal should dominate over the signal coming from the indoor DAS.</p>
<p>List of Channels in the Radio System/System Operational Frequency Passband</p>	<p><b>Provided by AHJ and/or FCC License Holder.</b> For Class A BDA applications, the complete list of radio channels used by the radio system. For Class B BDA applications, the system operational Frequency Passbands are required to be known (Start and Stop Frequency).</p> <p>Used to program the digital filter passbands of the BDA.</p>

### 3.3 COMMISSIONING PROCEDURE - BDA

Perform the following procedures for stand-alone **BDA** system commissioning. Refer to Figure 88 and Table 12 below.

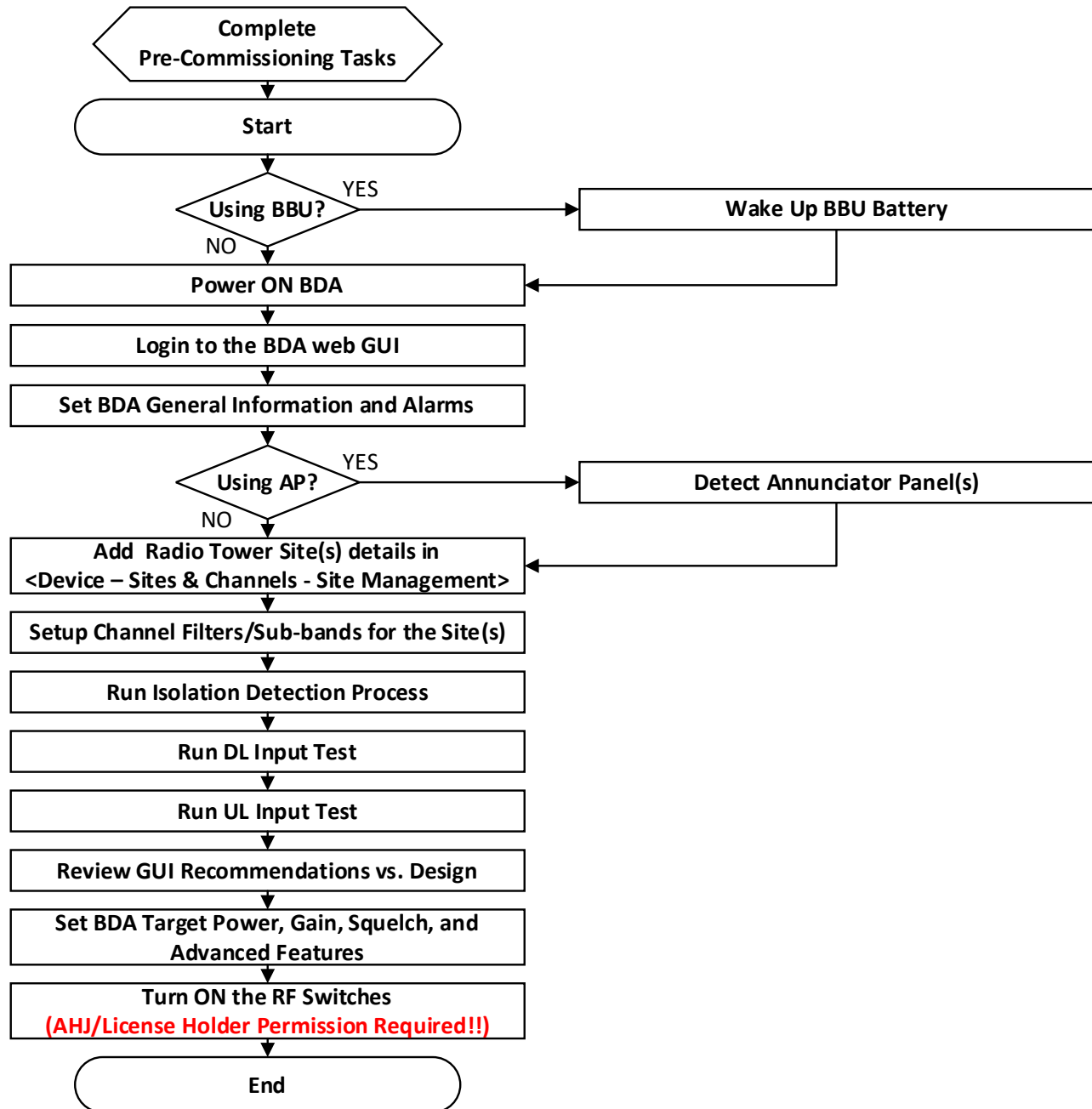

Figure 88: V3 BDA Commissioning Procedure

Table 12: V3 BDA Commissioning Tasks Explanation

Commissioning Task	Explanation of Task
1. Complete Pre-Commissioning Tasks	<ul style="list-style-type: none"> <li>● Complete ALL pre-commissioning tasks. Refer to section 3.1</li> </ul>
2. Start	<ul style="list-style-type: none"> <li>● Start of the Commissioning Process</li> </ul>
3. Wake Up BBU Battery	<ul style="list-style-type: none"> <li>● Wake up the Battery. Refer to section 3.6</li> </ul>
4. Power ON BDA System	<ul style="list-style-type: none"> <li>● Power ON the BDA system. Refer to section 3.9</li> </ul>
5. Login to the BDA web GUI	<ul style="list-style-type: none"> <li>● Using a laptop, login to the Graphical User Interface to program the BDA. Refer to section 3.10</li> </ul>
6. Set BDA General Information and Alarms	<ul style="list-style-type: none"> <li>● User Management. Setup user accounts and permissions. Refer to section 3.10</li> <li>● Set Device Information (name, location, Lat/Long, etc.). Refer to section 3.16 and, 3.17,</li> <li>● Setup Alarm Configuration. Refer to section 3.18</li> <li>● Setup Battery Backup Configuration. Refer to section 3.19</li> </ul>
7. Detect Annunciator Panel(s)	<ul style="list-style-type: none"> <li>● Navigate to &lt;Device – Overview – External Annunciator Panel&gt; to detect the APs. Refer to section 3.20</li> </ul>
8. Add Radio Tower Site(s) details in <Device - Sites & Channels – Site Management>	<ul style="list-style-type: none"> <li>● Add a radio site (Name, Address, System Type). Note: If the system utilizes more than one radio site, the user can add multiple sites. Refer to Section 3.21</li> </ul>
9. Setup Channel Filters/Sub-bands for the Site(s)	<ul style="list-style-type: none"> <li>● Enter the total number of channels or number of sub-bands</li> <li>● Enter the frequency details for channel filters/sub-bands</li> <li>● Enter the digital filter BW for all the channels/sub-bands</li> <li>● Select the <u>active</u> control channel(s) in the description column</li> </ul> Refer to sections 3.21 and 3.22
10. Run Isolation Detection Process	<ul style="list-style-type: none"> <li>● Measures the isolation between the donor antenna and service antenna branches. Users can use the onboard measurement tool or enter a manual measurement. Refer to section 3.25</li> </ul>
11. Run DL Input Test	<ul style="list-style-type: none"> <li>● Measures the DL Input Power of the assigned Control Channel. Users can use the onboard measurement tool or enter a manual measurement. Refer to section 3.23</li> </ul>
12. Run UL Input Test	<ul style="list-style-type: none"> <li>● Measures the range of UL Input Power seen from portables within the coverage area. Users can use the onboard measurement tool or enter a manual measurement. Refer to section 3.24</li> </ul>
13. Review GUI Recommendations vs. Design	<ul style="list-style-type: none"> <li>● The commissioning guide will generate recommended DL/UL Target Power and Gain settings based on the user inputs and results of the 3 commissioning tests. The commissioning guides recommended settings should be compared to the system design parameters to identify any inconsistencies that may require further troubleshooting.</li> <li>● If a user decides to use the recommended settings, the user will still need to set all the Target Powers and Gains manually in the “Device” pages. Refer to Section 3.26</li> </ul>
14. Set BDA Target Power, Gain, Squelch, and Advanced Features	<ul style="list-style-type: none"> <li>● Set the BDA DL and UL Channel Target Power</li> <li>● Set the DL and UL Gains</li> <li>● Set the DL and UL Squelch Thresholds</li> <li>● Turn ON NetProtect UL PA Muting, Oscillation Detection, and Donor Disconnection Detection. Refer to sections 3.27 through 3.35</li> </ul>
15. Turn ON the RF Switches	<ul style="list-style-type: none"> <li>● Turn on Channel RF Switches. Refer to section 3.27</li> <li>● Turn on Main RF Switches. Refer to section 3.28</li> </ul>
16. End	<ul style="list-style-type: none"> <li>● End of the Commissioning Process</li> </ul>

### 3.4 COMMISSIONING PROCEDURE – FIBER DAS OPTION 1

Perform the following procedures for **Fiber DAS** system commissioning. Refer to Figure 89 and Table 13 below.

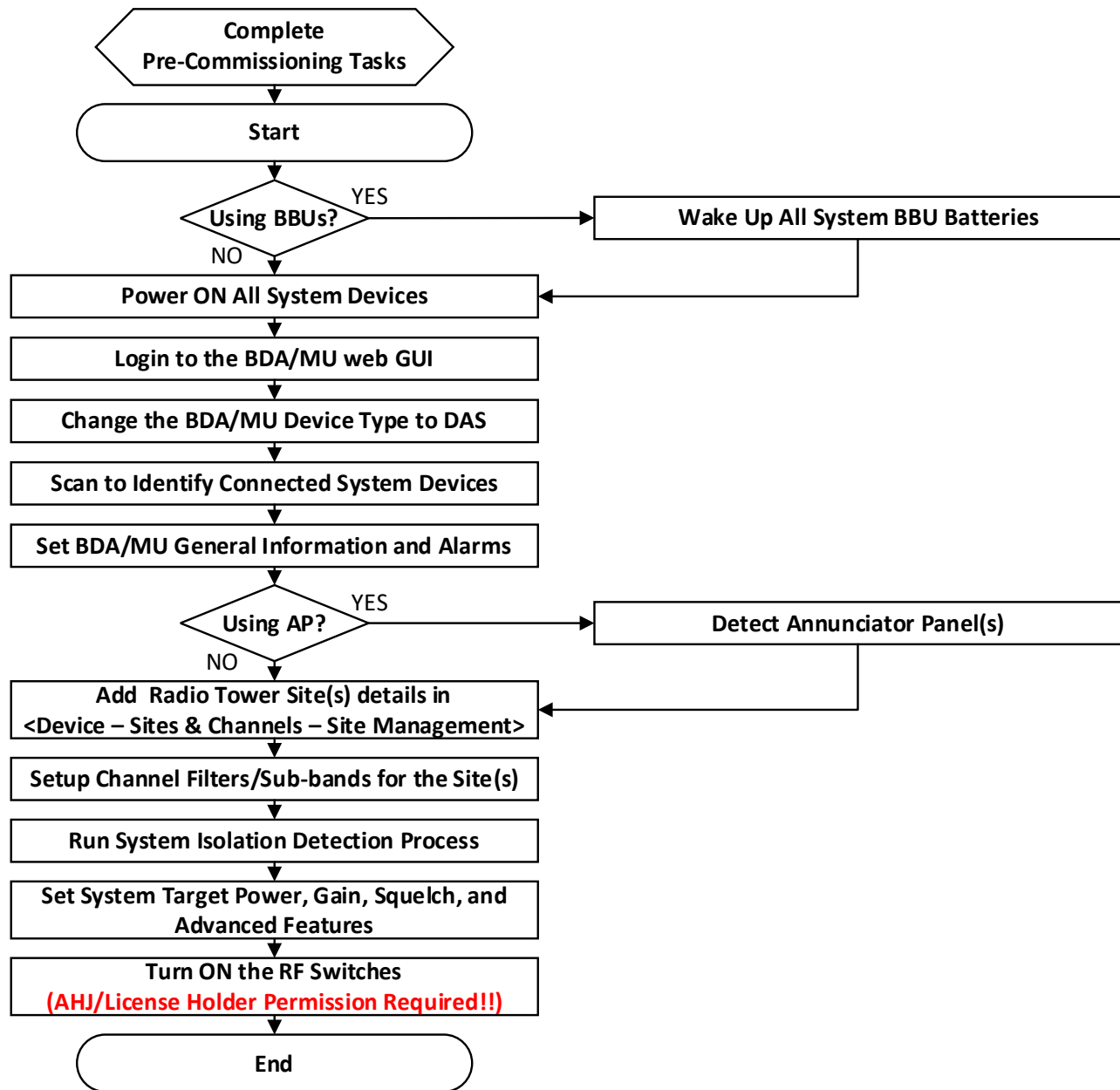

Figure 89: V3 Fiber DAS Commissioning Procedure Option 1

Table 13: V3 Fiber DAS Commissioning Procedure Explanation Option 1

Commissioning Tasks	Observation
1. Complete Pre-Commissioning Tasks	<ul style="list-style-type: none"> <li>● Complete ALL pre-commissioning tasks. Refer to section 3.1</li> </ul>
2. Start	<ul style="list-style-type: none"> <li>● Start of the Commissioning Process</li> </ul>
3. Wake Up All System BBU Batteries	<ul style="list-style-type: none"> <li>● Wake up all the Batteries in the system for all BDA/MU, FOU, and RU devices. Refer to section 3.6</li> </ul>
4. Power ON All System Devices	<ul style="list-style-type: none"> <li>● Power ON the BDA/MU, FOUs, and RUs in the system. Refer to section 3.9</li> </ul>
5. Login to the BDA/MU web GUI	<ul style="list-style-type: none"> <li>● Using a laptop, login to the Graphical User Interface to program the BDA/MU. Refer to section 3.10</li> </ul>
6. Change the BDA/MU Device Type to DAS	<ul style="list-style-type: none"> <li>● Navigate to &lt;Management - Device Information&gt; section to change the Device Type from BDA to DAS. Refer to section 3.13</li> </ul>
7. Scan to Identify Connected System Devices	<ul style="list-style-type: none"> <li>● Navigate to &lt;Dashboard&gt; and run a Scan. Wait a few minutes for all the system devices to be identified and shown in the system tree. Refer to section 3.15</li> </ul>
8. Set BDA/MU General Information and Alarms	<ul style="list-style-type: none"> <li>● User Management. Setup user accounts and permissions. Refer to section 3.10</li> <li>● Set Device Information (name, location, Lat/Long, etc.). Refer to section 3.16, 3.17, and 3.18</li> <li>● Setup Alarm Configuration. Refer to section 3.19</li> <li>● Setup Battery Backup Configuration. Refer to section 3.20</li> </ul>
9. Detect Annunciator Panel(s)	<ul style="list-style-type: none"> <li>● Navigate to &lt;Home – MU – AP &gt; to detect the APs. Refer to section 3.21</li> </ul>
10. Add Radio Tower Site(s) details in <Device - Sites & Channels – Site Management>	<ul style="list-style-type: none"> <li>● Add a radio site (Name, Address, System Type). Note: If the system utilizes more than one radio site, the user can add multiple sites. Refer to section 3.22</li> </ul>
11. Setup Channel Filters/Sub-bands for the Site(s)	<ul style="list-style-type: none"> <li>● Enter the total number of channels or number of sub-bands</li> <li>● Enter the frequency details for channel filters/sub-bands</li> <li>● Enter the digital filter BW for all the channels/sub-bands</li> <li>● Select the <u>active</u> control channel(s) in the description column Refer to sections 3.22 and 3.23</li> </ul>
12. Run System Isolation Detection Process	<ul style="list-style-type: none"> <li>● Measures the isolation between the donor antenna and service antenna branches. Users can use the onboard measurement tool or enter a manual measurement. Refer to section 3.26</li> </ul>
13. Set System Target Power, Gain, Squelch, and Advanced Features	<ul style="list-style-type: none"> <li>● Set the BDA/MU and RU DL and UL Channel Target Powers</li> <li>● Set the BDA/MU and RU DL and UL Gains</li> <li>● Set the BDA/MU and RU DL and UL Squelch Thresholds</li> <li>● Turn ON NetProtect UL PA Muting, Oscillation Detection, and Donor Disconnection Detection. Refer to sections 3.28 through 3.36</li> </ul>
14. Turn ON the RF Switches	<ul style="list-style-type: none"> <li>● Turn on Channel RF Switches</li> <li>● Turn on Main RF Switches Refer to section 3.29</li> </ul>
15. End	<ul style="list-style-type: none"> <li>● End of the Commissioning Process</li> </ul>

### 3.5 COMMISSIONING PROCEDURE – FIBER DAS OPTION 2

Perform the following procedures for **Fiber DAS** system commissioning. In this alternate procedure, the BDA/MU is commissioned in BDA mode first, before converting the system to DAS mode. This allows the user to maintain access to the DL Input Test and UL Input Test features in the BDA. Once the BDA has been commissioned, the BDA/MU is converted to DAS mode and the remaining devices in the system are commissioned. Refer to Figure 90 and Table 14 below.

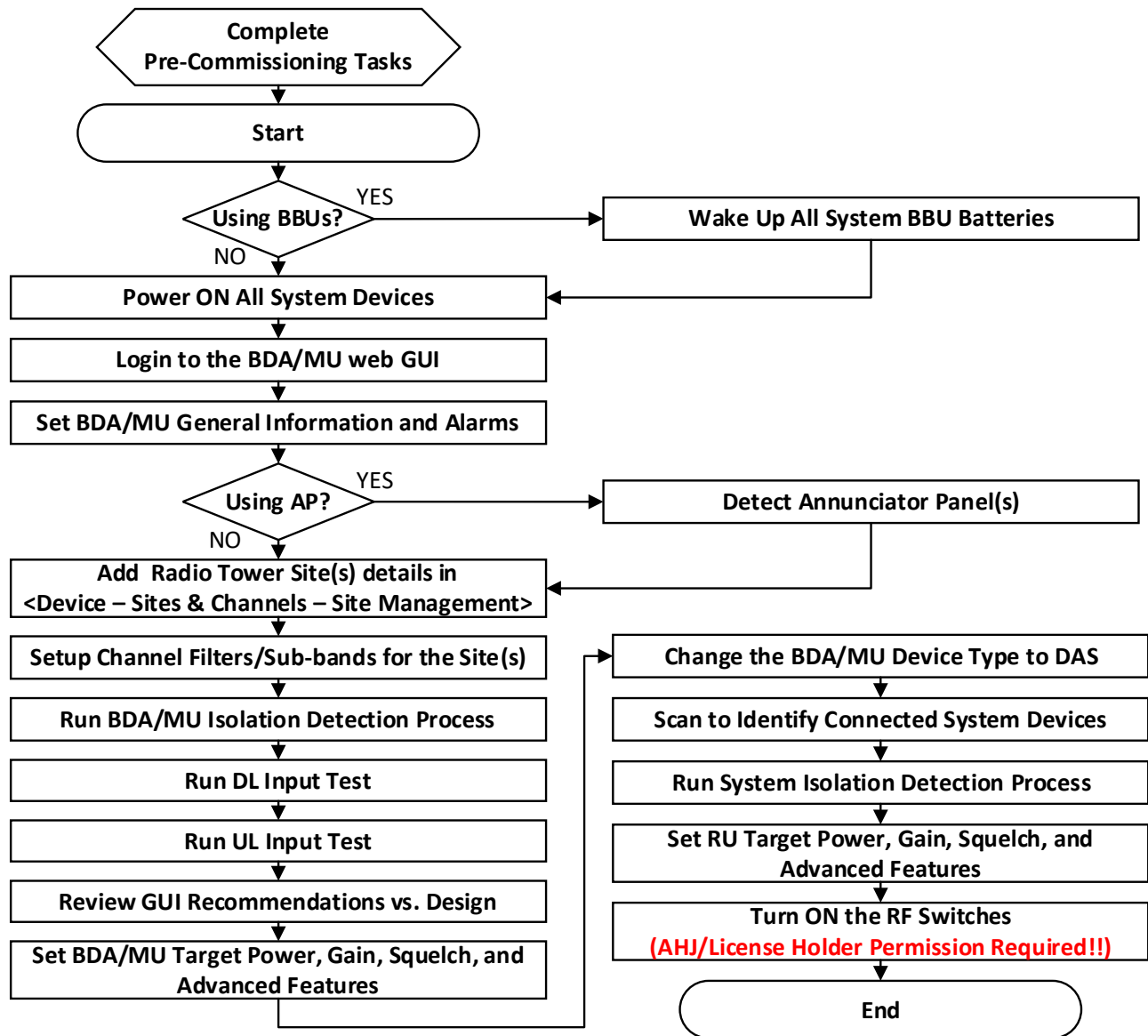

Figure 90: V3 Fiber DAS Commissioning Procedure Option 2

Table 14: V3 Fiber DAS Commissioning Procedure Explanation Option 2

Commissioning Tasks	Observation
1. Complete Pre-Commissioning Tasks	<ul style="list-style-type: none"> <li>● Complete ALL pre-commissioning tasks. Refer to section 3.1</li> </ul>
2. Start	<ul style="list-style-type: none"> <li>● Start of the Commissioning Process</li> </ul>
3. Wake Up All System BBU Batteries	<ul style="list-style-type: none"> <li>● Wake up all the Batteries in the system for al BDA/MU, FOU, and RU devices. Refer to section 3.6</li> </ul>
4. Power ON All System Devices	<ul style="list-style-type: none"> <li>● Power ON the BDA/MU, FOUs, and RUs in the system. Refer to section 3.9</li> </ul>
5. Login to the BDA/MU web GUI	<ul style="list-style-type: none"> <li>● Using a laptop, login to the Graphical User Interface to program the BDA/MU. Refer to section 3.10</li> </ul>
6. Set BDA/MU General Information and Alarms	<ul style="list-style-type: none"> <li>● User Management. Setup user accounts and permissions. Refer to section 3.10</li> <li>● Set Device Information (name, location, Lat/Long, etc.). Refer to section 3.16, 3.17, and 3.18</li> <li>● Setup Alarm Configuration. Refer to section 3.19</li> <li>● Setup Battery Backup Configuration. Refer to section 3.20</li> </ul>
7. Detect Annunciator Panel(s)	<ul style="list-style-type: none"> <li>● Navigate to &lt;Home – MU – AP &gt; to detect the APs. Refer to section 3.21</li> </ul>
8. Add Radio Tower Site(s) details in <Device - Sites & Channels – Site Management>	<ul style="list-style-type: none"> <li>● Add a radio site (Name, Address, System Type). Note: If the system utilizes more than one radio site, the user can add multiple sites. Refer to section 3.22</li> </ul>
9. Setup Channel Filters/Sub-bands for the Site(s)	<ul style="list-style-type: none"> <li>● Enter the total number of channels or number of sub-bands</li> <li>● Enter the frequency details for channel filters/sub-bands</li> <li>● Enter the digital filter BW for all the channels/sub-bands</li> <li>● Select the <u>active</u> control channel(s) in the description column Refer to sections 3.22 and 3.23</li> </ul>
10. Run Isolation Detection Process	<ul style="list-style-type: none"> <li>● Measures the isolation between the donor antenna and service antenna branches. Users can use the onboard measurement tool or enter a manual measurement. Refer to section 3.26</li> </ul>
11. Run DL Input Test	<ul style="list-style-type: none"> <li>● Measures the DL Input Power of the assigned Control Channel. Users can use the onboard measurement tool or enter a manual measurement. Refer to section 3.24</li> </ul>
12. Run UL Input Test	<ul style="list-style-type: none"> <li>● Measures the range of UL Input Power seen from portables within the coverage area. Users can use the onboard measurement tool or enter a manual measurement. Refer to section 3.25</li> </ul>
13. Review GUI Recommendations vs. Design	<ul style="list-style-type: none"> <li>● The commissioning guide will generate recommended DL/UL Target Power and Gain settings based on the user inputs and results of the 3 commissioning tests. The commissioning guide recommended settings should be compared to the system design parameters to identify any inconsistencies that may require further troubleshooting.</li> <li>● If a user decides to use the recommended settings, the user will still need to set all the Target Powers and Gains manually in the “Device” pages. Refer to Section 3.27</li> </ul>
14. Set BDA/MU Target Power, Gain, Squelch, and Advanced Features	<ul style="list-style-type: none"> <li>● Set the BDA DL and UL Channel Target Power</li> <li>● Set the DL and UL Gains</li> <li>● Set the DL and UL Squelch Thresholds</li> <li>● Turn ON NetProtect UL PA Muting, Oscillation Detection, and Donor Disconnection Detection. Refer to sections 3.28 through 3.36</li> </ul>
15. Change the BDA/MU Device Type to DAS	<ul style="list-style-type: none"> <li>● Navigate to &lt;Management - Device Information&gt; section to change the Device Type from BDA to DAS. Refer to section 3.13</li> </ul>

16. Scan to Identify Connected System Devices	<ul style="list-style-type: none"> <li>● Navigate to &lt;Dashboard&gt; and run a Scan. Wait a few minutes for all the system devices to be identified and shown in the system tree. Refer to section 3.15</li> </ul>
17. Run System Isolation Detection Process	<ul style="list-style-type: none"> <li>● Measures the isolation between the donor antenna and service antenna branches. Users can use the onboard measurement tool or enter a manual measurement. Refer to section 3.26</li> </ul>
18. Set RU Target Power, Gain, Squelch, and Advanced Features	<ul style="list-style-type: none"> <li>● Set the RU DL and UL Channel Target Powers</li> <li>● Set the RU UL Gains</li> <li>● Set the RU UL Squelch Thresholds</li> <li>● Turn ON NetProtect UL PA Muting and Oscillation Detection for RU devices. Refer to section 3.28 through 3.36</li> </ul>
19. Turn ON the RF Switches	<ul style="list-style-type: none"> <li>● Turn on Channel RF Switches</li> <li>● Turn on Main RF Switches</li> </ul> <p>Refer to section 3.29</p>
20. End	<ul style="list-style-type: none"> <li>● End of the Commissioning Process</li> </ul>

### 3.6 V3 BBU – WAKE UP/TURN ON THE BATTERY

Before powering on the system, each BBU battery must be awakened/turned ON, so it is ready to use. This allows the Battery Management System (BMS) to start up on battery power and be ready to communicate with the charging system within the BDA/MU or RU.

- Push and hold the recessed RESET button located on top of the LiFEPO4 battery for approximately 3 seconds to wake up the battery. Once the SOC (State of Charge) LEDs begin to illuminate, release the RESET button immediately (NOTE: Holding the RESET button longer than approximately 5 seconds will cause the battery to go back into sleep mode. If this occurs, repeat the step to “wake-up” the battery). See Figure 91 below.

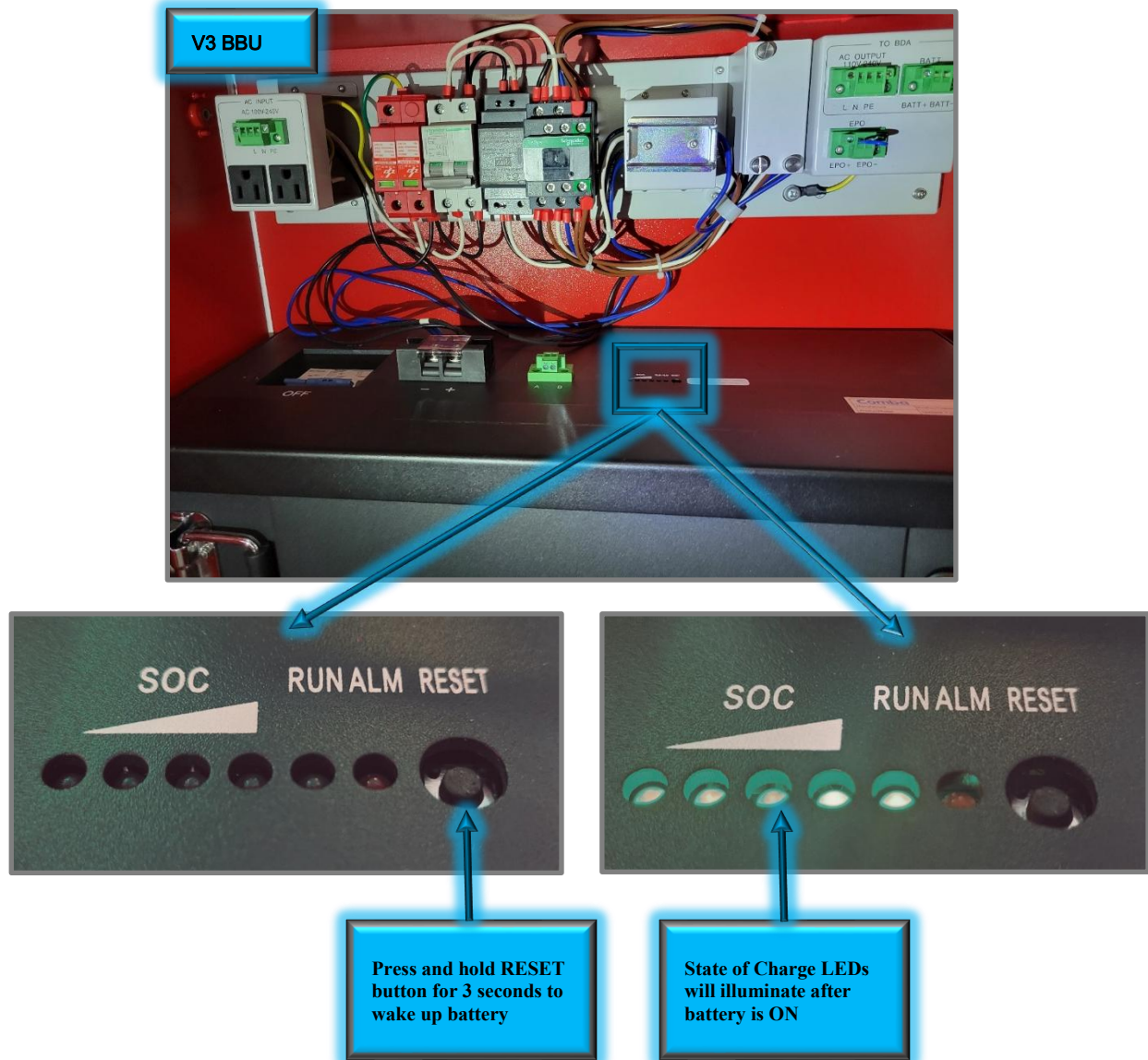

Figure 91: V3 BBU – Waking Up/Turning ON Battery

### 3.7 V3 BBU – BATTERY SLEEP MODE/TURN OFF THE BATTERY

- Push and hold the recessed RESET button located on top of the LiFEPO4 battery for approximately 3 seconds to put the battery to sleep. Once all the SOC (State of Charge) LEDs begin to extinguish, release the RESET button immediately (NOTE: Holding the RESET button longer than approximately 5 seconds will cause the battery to wake back up. If this occurs, repeat the step to “Put battery to sleep”). See Figure 91 for more details.

### 3.8 V3 BBU – BATTERY ALARM RESET

- The Battery has an ALM LED which illuminates RED if any issues are detected. To reset/clear the battery alarm, push and hold the recessed RESET button located on top of the LiFePO4 battery for approximately 10 seconds to reset the Battery MCU and clear any Battery Alarms. Once all the SOC (State of Charge) LEDs begin to re-illuminate, release the RESET button immediately. See Figure 91 for details on where the RESET button is located.

### 3.9 V3 BDA/MU/FOU/RU POWER ON AND POWER OFF

Before proceeding, double-check that all the wire connections are secured, and polarities are correct for all AC and DC connections. Refer to Figure 92 for details on the locations of switches and breakers.

- **Power ON the system (with V3 BBU):**
  1. Turn ON the FOU Power Switch (If using Fiber DAS)
  2. Turn ON AC Switch in the BDA/MU/RU
  3. Turn the DC IN/BATT CHRG Switch to “BATT CHRG”
  4. Turn ON Battery Breaker on the battery
  5. Turn ON the AC Breaker in the BBU
- **Power OFF the System (with V3 BBU)**
  1. Turn OFF AC Breaker in the BBU
  2. Turn OFF Battery Breaker on the battery
  3. Turn OFF AC Switch in the BDA/MU/RU
  4. Turn OFF the FOU Power Switch (If using Fiber DAS)
- **Power ON the system (no V3 BBU, direct AC Connection to BDA):**
  1. Turn ON the FOU Power Switch (If using Fiber DAS)
  2. Turn ON AC Switch in the BDA/MU/RU
- **Power OFF the System (no V3 BBU, direct AC Connection to BDA):**
  1. Turn OFF AC Switch in the BDA/MU/RU
  2. Turn OFF the FOU Power Switch (If using Fiber DAS)
- **Power ON the system (no V3 BBU, direct 48VDC Connection to BDA from third-party source):**
  1. Turn ON the FOU Power Switch (If using Fiber DAS)
  2. Turn DC Switch to “DC IN”
  3. Turn on third-party 48VDC Power source
- **Power OFF the System (no 3 BBU, direct 48VDC Connection to BDA from third-party source):**
  1. Turn OFF third-party 48VDC Power source
  2. Turn OFF the FOU Power Switch (If using Fiber DAS)

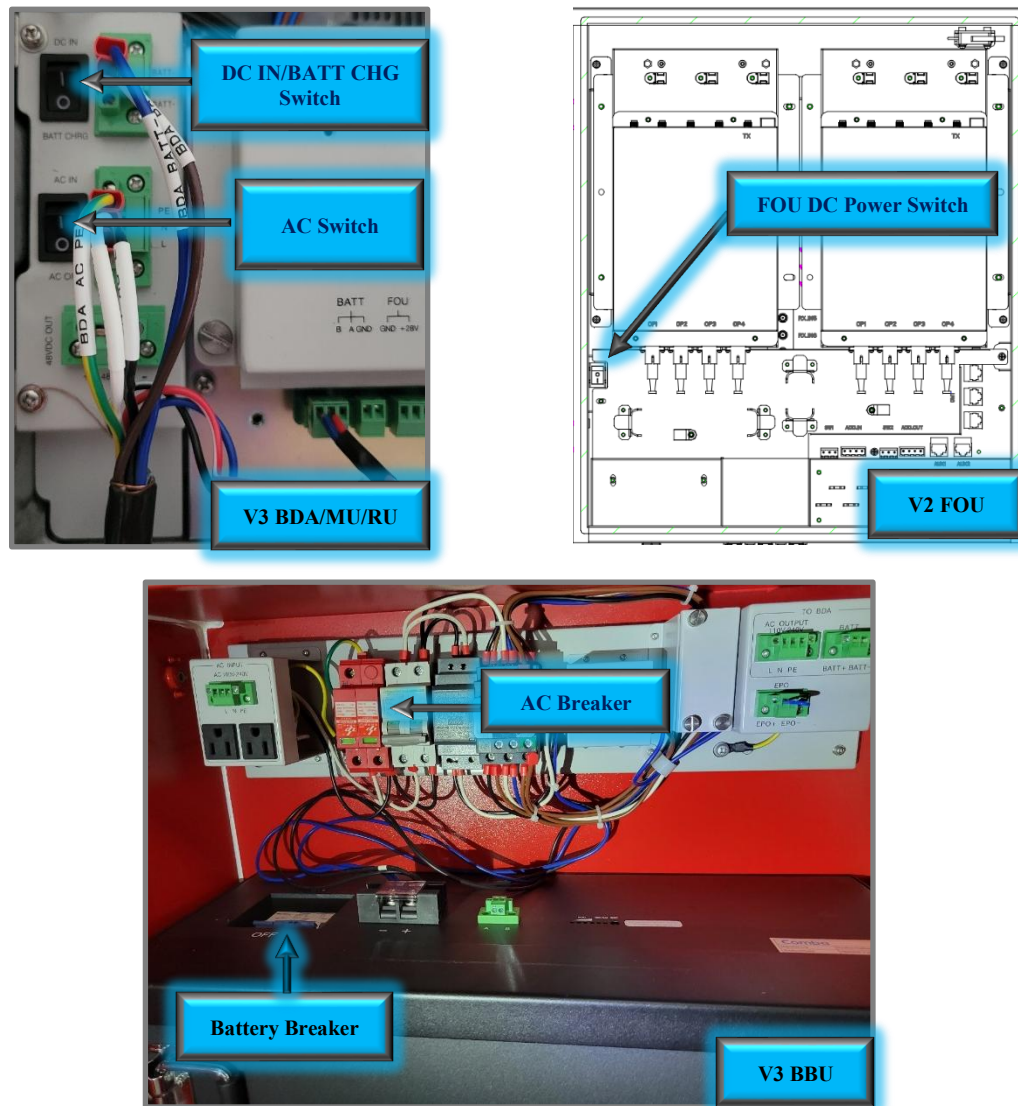

Figure 92: BDA/MU/RU, BBU, and FOU Power Switches and Breakers

Note: For V3 BDA/MU/RU devices using a Comba V3 BBU, the DC (DC IN / BATT CHR) switch in the BDA can be used to turn on the system when there is no main AC power source established, and the system can boot up with DC Battery power only. It is highly recommended to **leave it to “BATT CHR”** when using BBU V3. **Switch to DC IN** to power up from battery only or when using Comba BBU V2 or other third party BBU products.

Caution: During the construction phase of a project, the main AC power to the system might be intermittent due to temporary service outages. It is highly recommended to keep the system powered down and to put the battery to sleep until the device is commissioned for permanent use. If an active V3 system loses AC power for more than its designed backup runtime (typically 12-24 hours), the battery may drain to a point where it will automatically go into sleep mode to prevent itself from being damaged and unrecoverable. If the battery automatically goes to sleep, you must manually wake up the battery again to restore normal operation. See section 3.6 for details on awakening/turning ON the battery.

### 3.10 WEB GUI LOGIN AND USER MANAGEMENT

The V3 BDA/MU/RU and V2 FOU devices can be monitored and controlled via the WEB GUI; use the following instructions to login to the GUI for system parameter setting and commissioning.

#### BDA/MU or RU Login

- Set the computer IP address to 192.168.8.xxx (except 101) / 255.255.255.0. (e.g. 192.168.8.100)
- Connect the computer to the **OMT Port** on the device using a regular Ethernet RJ45 Cable.
- Use the default device IP address of **http://192.168.8.101** in the browser to login to the device. Enter full address with the <http://> all the time. Some browsers will default to use <https> and not be able to access the device if just typing 192.168.8.101.
- Use username **admin** and password **admin** for general web operation.
- There is an additional LAN port located on the BDA/MU only. The LAN port can be used for local access but more commonly used for remote access after being configured to connect to an external Modem / Router / Switch or a Gateway, etc...

**The LAN port IP can be configured in WEB → Management → Network.**

The LAN port default IP address is 192.168.0.101 / 255.255.255.0, and the Gateway is 192.168.0.1.

**Note: If the device is configured for remote connection using the LAN port, all the firmware upgrades for the BDA/MU, FOU, and RUs can be completed remotely through the BDA/MU without the need to send anyone to the site.**

#### FOU Login

- Set the computer IP address to 192.168.8.xxx (except 101) / 255.255.255.0. (e.g. 192.168.8.100)
- Connect the computer to the **OMT Port** on the device using a regular Ethernet RJ45 Cable.
- Use the default device IP address of **https://192.168.8.101** (**Must use https://**) in the browser to login to the device. Enter full address with the <https://> all the time for the FOU. If you receive any security warnings from the web browser, they can be ignored.
- First-time login: Use username **admin** and password **admin** for general web operation. If using an older FW version, the system may prompt you to set a new password. Change the password and notate accordingly.

**Note: use admin/Admin12345678 if admin/admin does not work.**

**User Management – Change Password**

- To change login password, navigate to the <Management – User Management – Password> Tab for the account which is currently logged in. Enter the new password and click <modify>. If the Admin account password has been lost, please call Comba Technical Support for assistance.

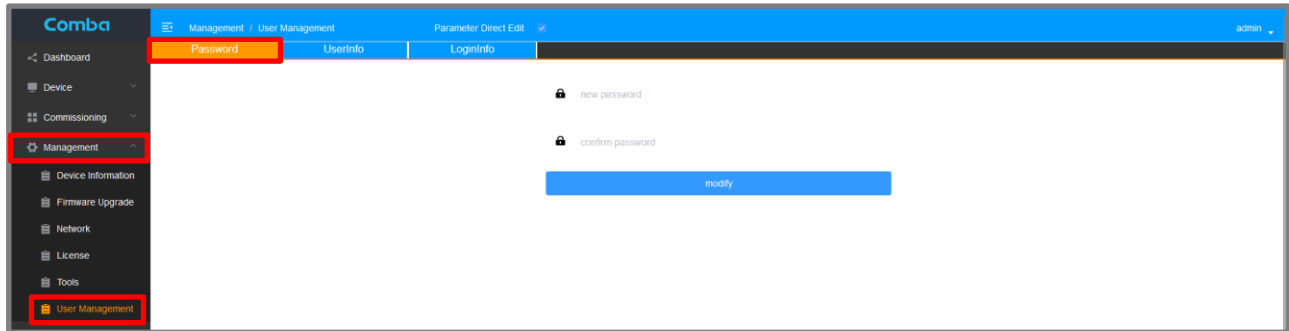

Figure 93: User Management - Change User Password

**User Management – Add/Delete users**

- Add/Delete users in <Userinfo> tab.
- In the <LoginInfo> tab, set <tryMax> to limit the MAX number of login attempts before the account is locked. If the Max Attempt is reached, this account will be locked.

The <guest> account can be unlocked in <Userinfo> tab using <admin> login. If <admin> account is locked, call Customer Service for assistance to unlock.

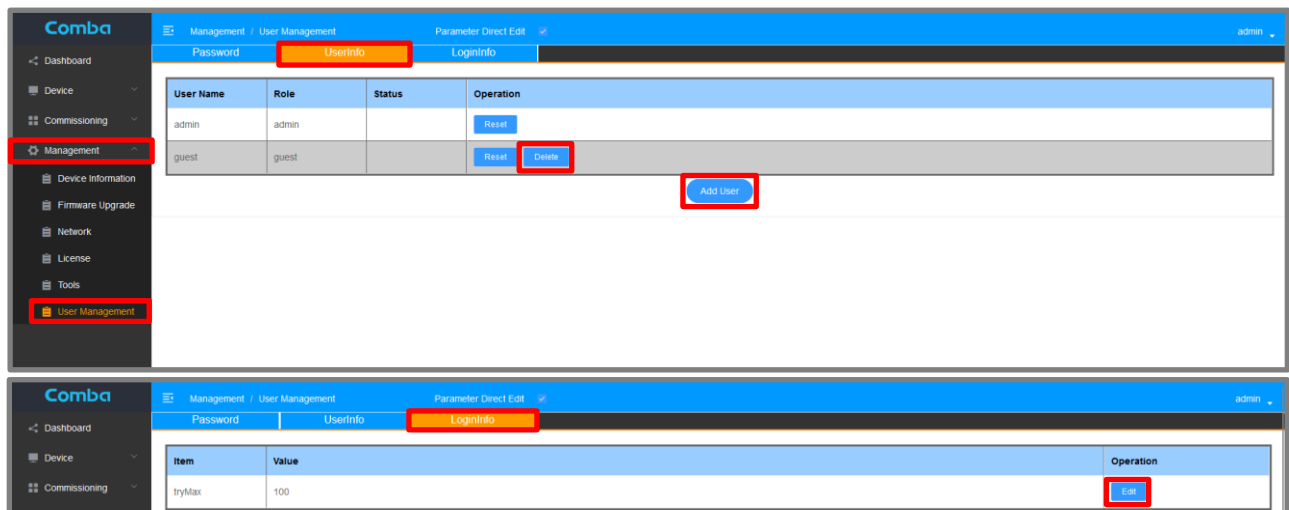

Figure 94: User Management - Add/Delete Users

### 3.11 WEB GUI OVERVIEW (BDA MODE)

See Figure 95 and Table 15 below which provide an overview of the web GUI when in BDA mode.

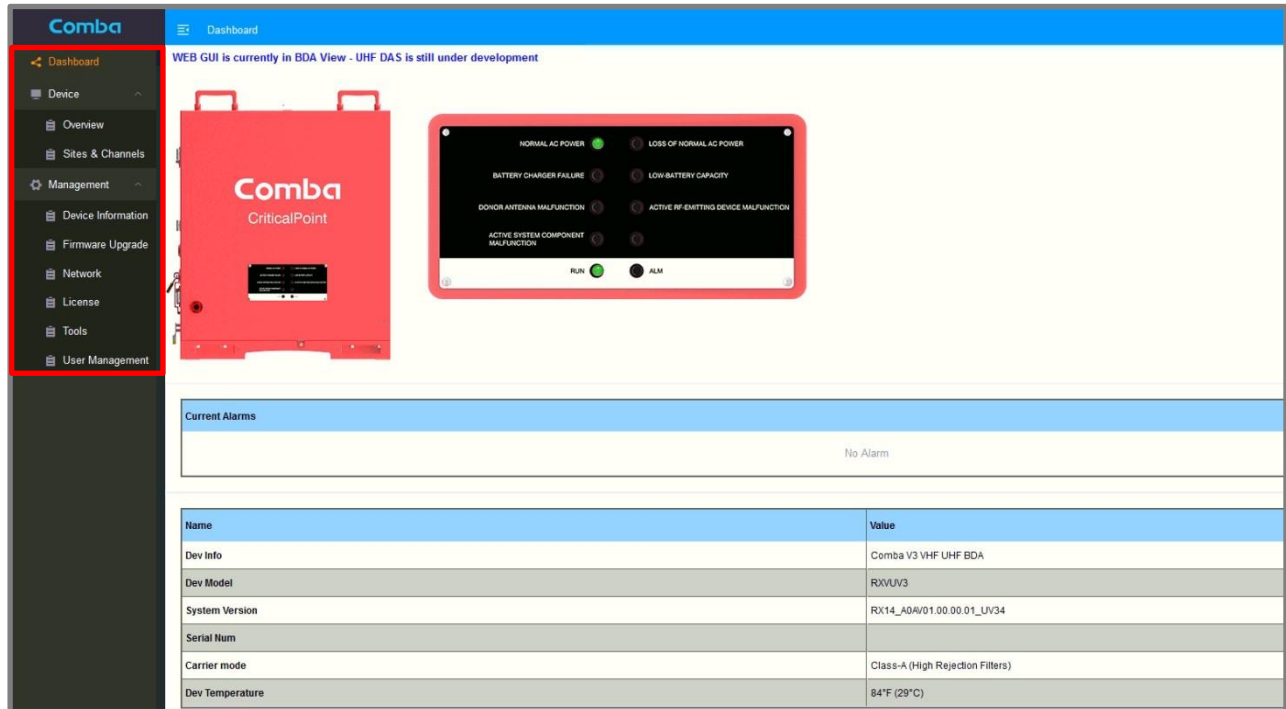

Figure 95: V3 BDA/MU Web GUI Overview (BDA Mode)

Table 15: V3 BDA/MU Web GUI Overview (BDA Mode)

Page	Description
Dashboard	<ul style="list-style-type: none"> <li>Check Device Current Status</li> </ul>
Device	<ul style="list-style-type: none"> <li>Main RF Settings</li> <li>Channel RF Settings</li> <li>Alarm Settings</li> <li>BBU Settings</li> <li>Annunciator Panel Settings</li> </ul>
Commissioning	<ul style="list-style-type: none"> <li>Isolation Detection Tool</li> <li>DL Measurement Tool</li> <li>UL Measurement Tool</li> </ul>
Management	<ul style="list-style-type: none"> <li>Device General Settings</li> <li>Network/SNMP Settings</li> <li>Firmware Upgrade</li> <li>License Management</li> <li>Tools (Reset / Alarm Logs / Report, etc.)</li> <li>User Management</li> </ul>

### 3.12 WEB GUI OVERVIEW (DAS MODE)

See Figure 96 and Table 16 below which provide an overview of the web GUI when in DAS mode.

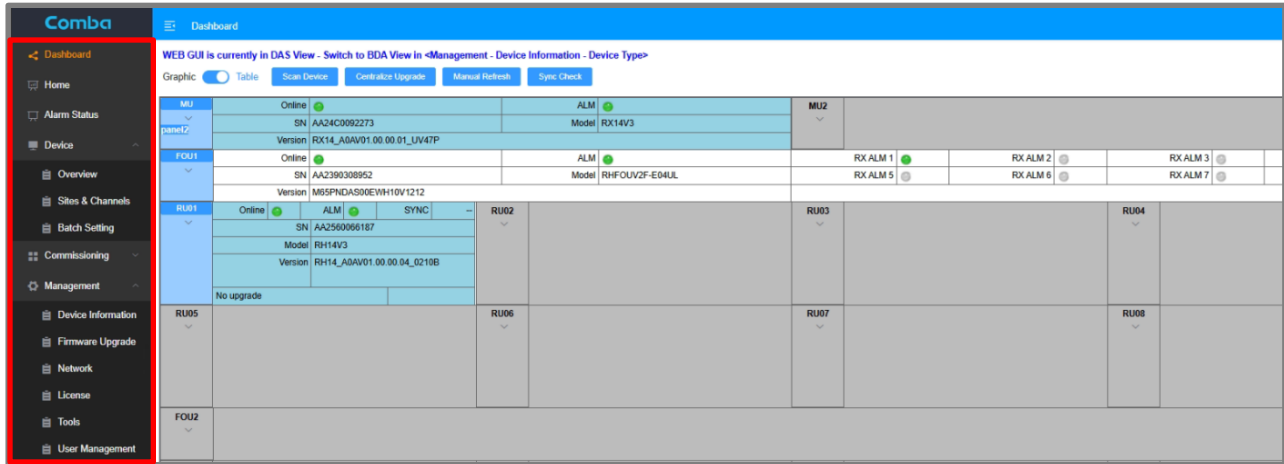

Figure 96: V3 BDA/MU Web GUI Overview (DAS Mode)

Table 16: V3 BDA/MU Web GUI Overview (DAS Mode)

Page	Descriptions
Dashboard	<ul style="list-style-type: none"> <li>• System Scan for Connected Devices</li> <li>• System Firmware Upgrade (Centralize Upgrade)</li> <li>• FOU and RU access (Table View)                             <ul style="list-style-type: none"> <li>○ RF Settings / Channel RF Settings</li> <li>○ Alarm Settings / BBU Settings / Annunciator Panel Settings</li> </ul> </li> </ul>
Home	<ul style="list-style-type: none"> <li>• Check Device Current Status</li> </ul>
Alarm Status	<ul style="list-style-type: none"> <li>• System Alarm Status</li> </ul>
Device	<ul style="list-style-type: none"> <li>• Isolation Check</li> <li>• RF Settings/ Channel RF Settings (MU)</li> <li>• Alarm Settings / BBU Settings / Annunciator Panel Settings</li> <li>• System Batch Settings</li> </ul>
Commissioning	<ul style="list-style-type: none"> <li>• Isolation Detection Tool</li> </ul>
Management	<ul style="list-style-type: none"> <li>• Device General Settings (MU)</li> <li>• Network/SNMP Settings (MU)</li> <li>• Firmware Upgrade (MU)</li> <li>• License Management (MU)</li> <li>• Tools (Reset / Alarm Logs / Report / System Report, etc.)</li> <li>• User Management (MU)</li> </ul>

### 3.13 CHANGING THE DEVICE OPERATING MODE/TYPE (BDA OR DAS)

If you are using the BDA/MU device in a Fiber DAS configuration, you must change the Device Operating mode (Device Type) in the GUI. The Device Type can be set to **BDA View** or **DAS View** to display and configure the system components correctly. The current view is indicated on the <Dashboard> Page. See Figure 97.

**Note:** The BDA/MU device uses the same firmware regardless of whether it is operating in BDA mode or in Fiber DAS mode.

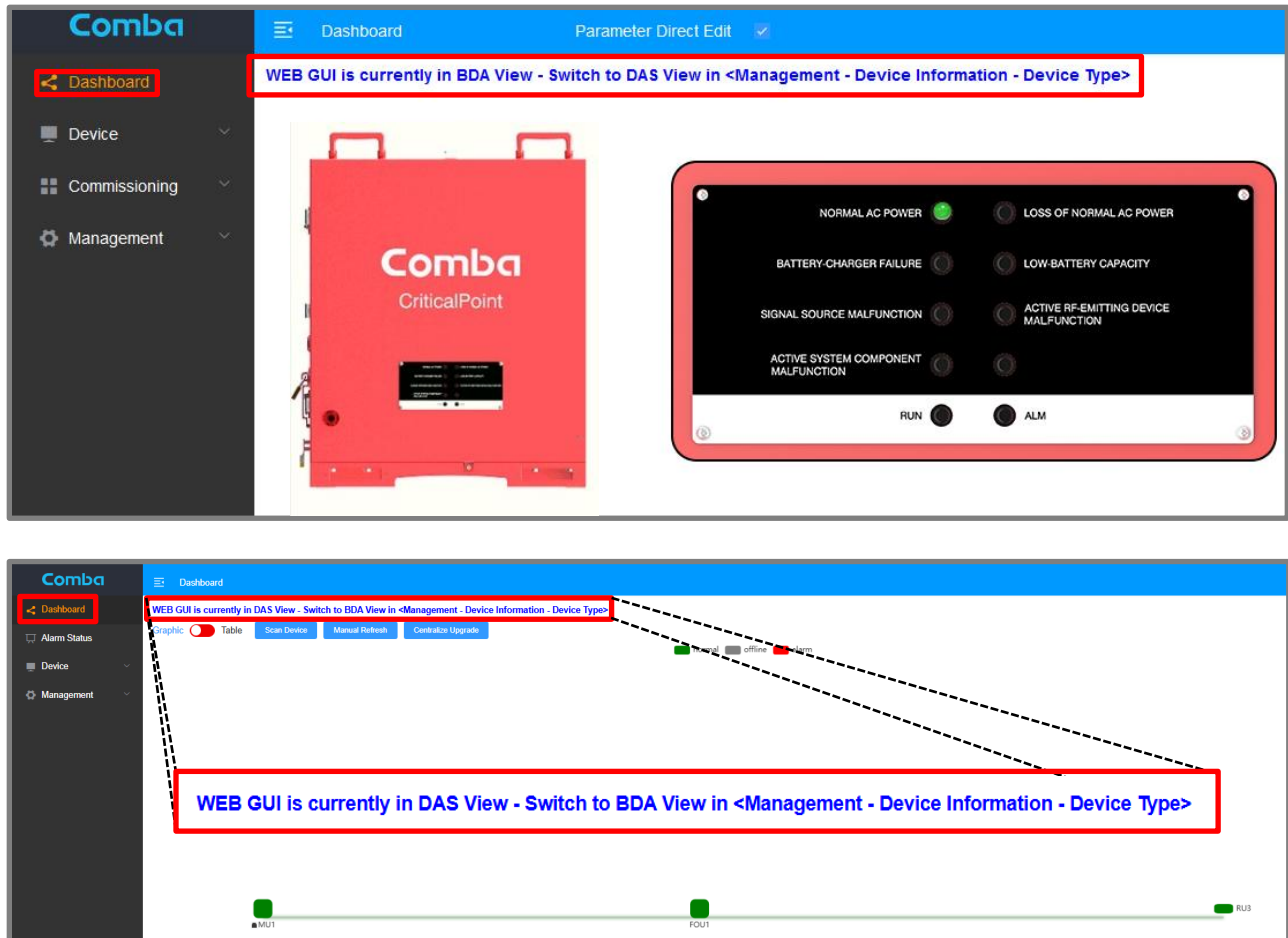

Figure 97: V3 BDA/MU Dashboard Viewing – BDA vs DAS mode

- To change the Device Type, navigate to <Management – Device Information – Device Type> and click <Modify>. After making the change, you will be logged out of the web GUI, and the new selected mode will be displayed after re-login. Note, upgrading the firmware will NOT change this setting. See Figure 98.

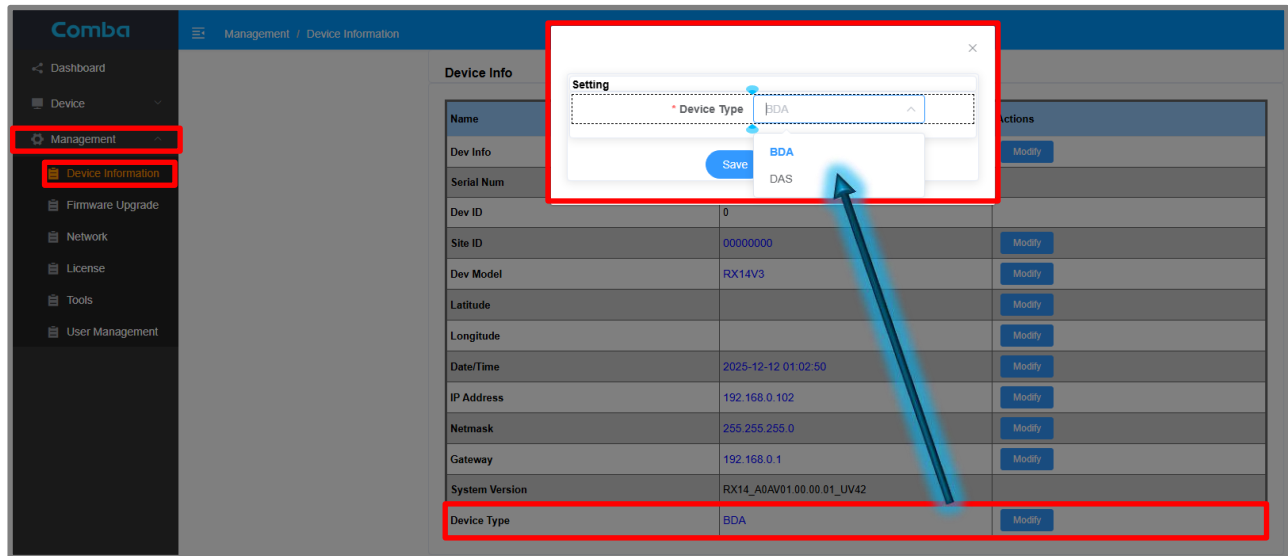

Figure 98: V3 BDA/MU Changing Device Operating Mode/Type (BDA or DAS)

**Note:** If a project requires a stand-alone BDA for the 1<sup>st</sup> phase of the project, and Fiber DAS components will be added later as part of an expansion phase, the BDA/MU can be commissioned in BDA mode. Once the Fiber DAS devices (FOUs and RUs) have been properly installed and powered up, the user can change the <Device Type> to DAS mode to commission the new fiber devices. All the BDA/MU settings will be retained and only FOU and RU devices will need to be commissioned. See section 3.5 Commissioning Fiber DAS Option 2 for more details.

### 3.14 MODIFYING PARAMETERS VS PARAMETER DIRECT EDIT

There are two different ways a user can change settings for a certain parameter of the device. The first option is to use the <Modify> button. By clicking on a <Modify> button, the user will be presented with a pop-up window which allows the user to make changes to one or several parameters all at once. This option is convenient during initial setup and commissioning to enter parameters quickly as a group. The user can also make changes to certain parameters throughout the GUI web pages by clicking directly on that parameters link which will be highlighted by blue text. This option is convenient if the user only wishes to make changes to one specific parameter. See Figure 99.

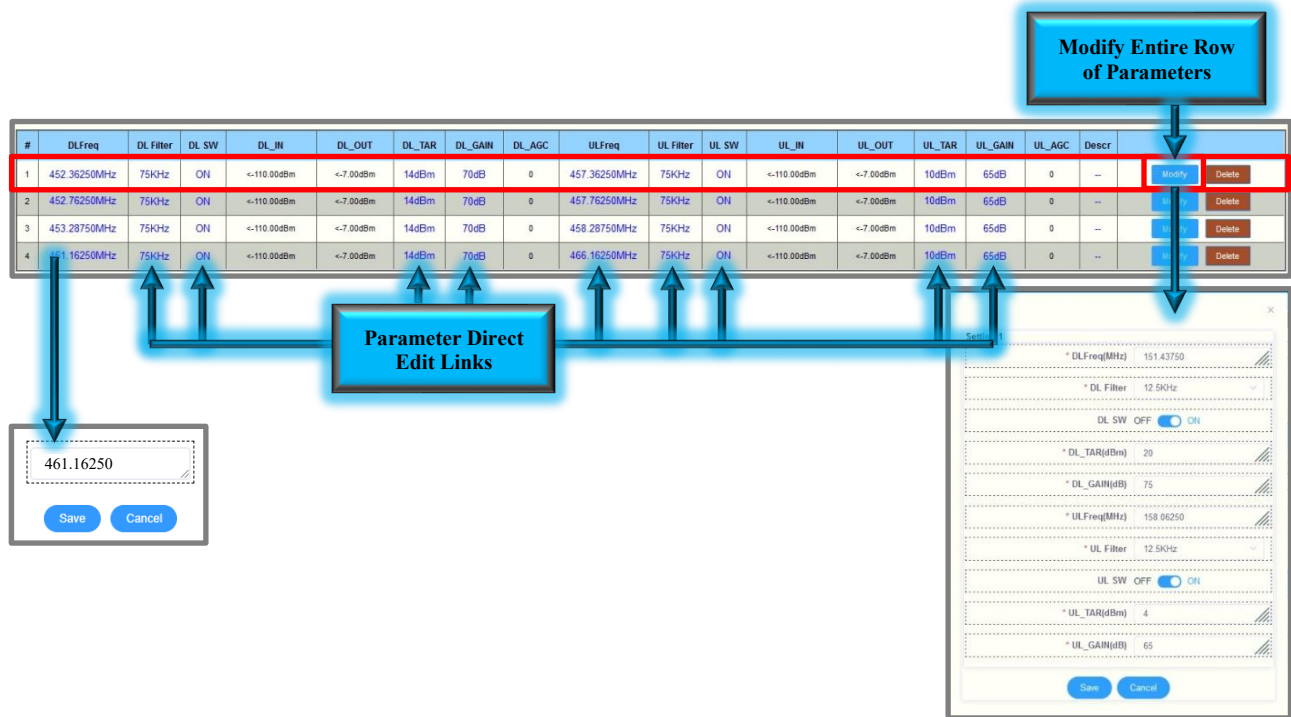

Figure 99: V3 BDA/MU/RU Modifying Parameters in the WEB GUI

### 3.15 V3 FIBER DAS – SCANNING, VIEWING AND ACCESSING DEVICES

When commissioning the system in a Fiber DAS configuration, the system <Device Type> must be changed to DAS mode and the user must perform a <Scan Device> to identify all the connected devices in the system.

#### Scanning for Devices

- Ensure all wiring and cabling has been properly installed/connected for FOU and Remote Units per the Installation section of this user manual.
- Login into the BDA/Master Unit and make sure the <Device Type> is set to DAS mode/view. Refer to section 3.13
- Navigate to <Dashboard> and click the <Scan Device> button. Click the <Scan> button in the pop-up window to start scanning for devices. It will take approximately 1 – 5 minutes to complete the scanning process depending on the number of FOU and RUs.

Note: Leave the window open when it is “scanning”. Click <Finish> to close the window once the scan has finished. All FOU and RUs should be populated after the scan has finished. See Figure 100 below.

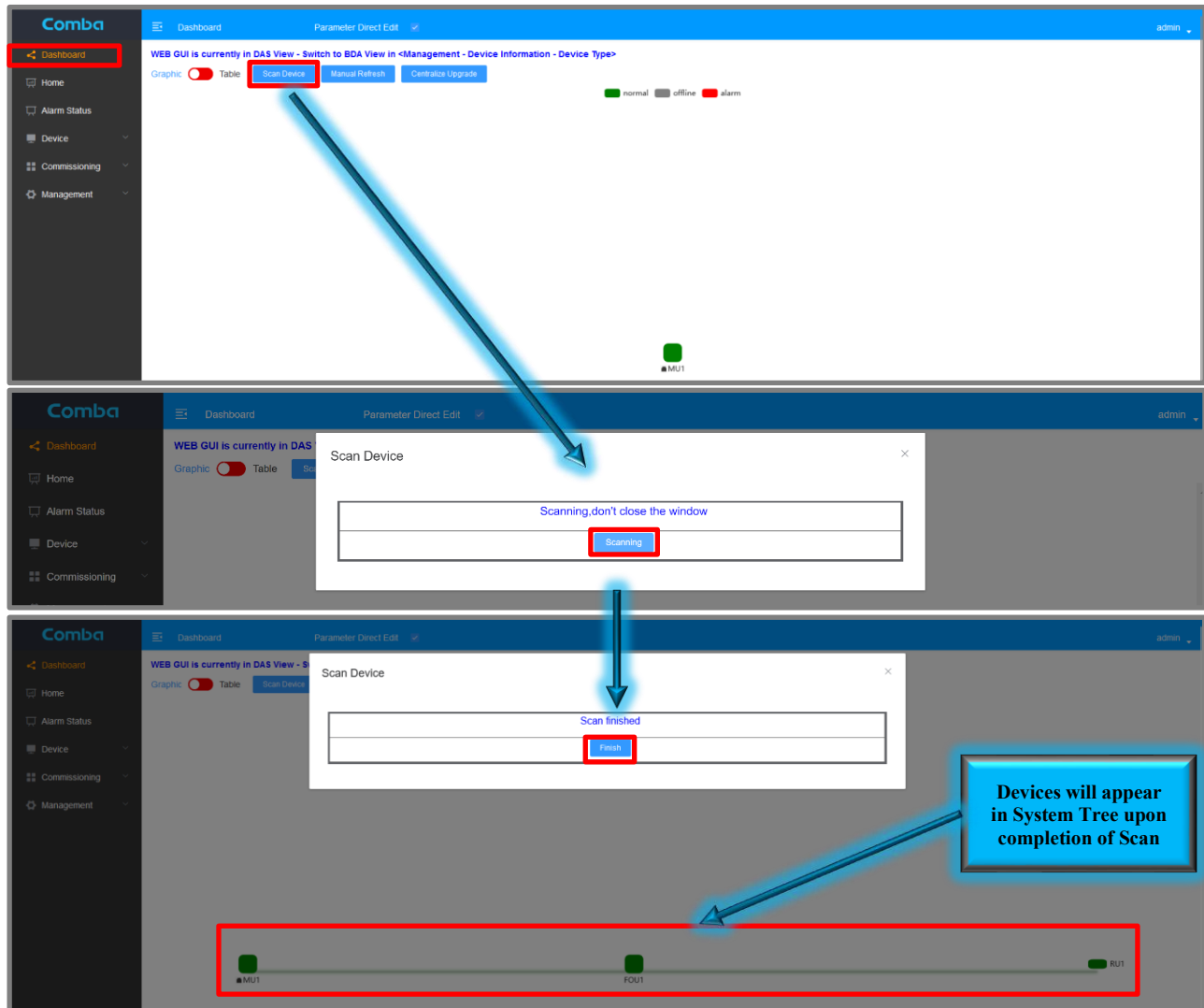

Figure 100: V3 Fiber DAS – Scanning to Identify Connected System Devices

## Viewing Devices:

There are two ways a user can choose to view the status of the system devices: Graphic View or Table View. The user can change viewing styles by clicking on the switch in the <Dashboard> screen. See Figure 101 and 102.

### **Graphic View:**

If Graphic View is selected, it will provide an intuitive diagram of how the system is connected. A floating window will pop up when moving the mouse over the device icon.

Device Icon Color Status Indicator:

- Green: Normal/No Alarms
- Red: Alarm(s) Active (Any device alarm, not limited to Dry Contact Alarms)
- Gray: Device is Disconnected

Graphic View is only used for viewing the system structure and basic device detail. Clicking on a device icon will not take you to the programming screens for that device.



Figure 101: V3 Fiber DAS – Dashboard Graphic View

**Table View:**

If Table View is selected, the system devices will be displayed in a table structure. Each device within the table will display status indicators as well as the device Model Number, Serial Number, and Current Firmware Version.

Online Status Indicators:

- Green: Normal/Device is Communicating
- Gray: Device is Disconnected

ALM Status Indicators:

- Green: Normal/No Alarms
- Red: Alarm(s) Active (Any device alarm, not limited to Dry Contact Alarms)
- Gray: Device is Disconnected

Table View is used for viewing the system structure, basic device details, and to access device programming pages. Clicking on a device icon will take you to the web programming screens for that device (with some limitations compared to direct local access). FOU and RU are clickable and accessible from Table View.

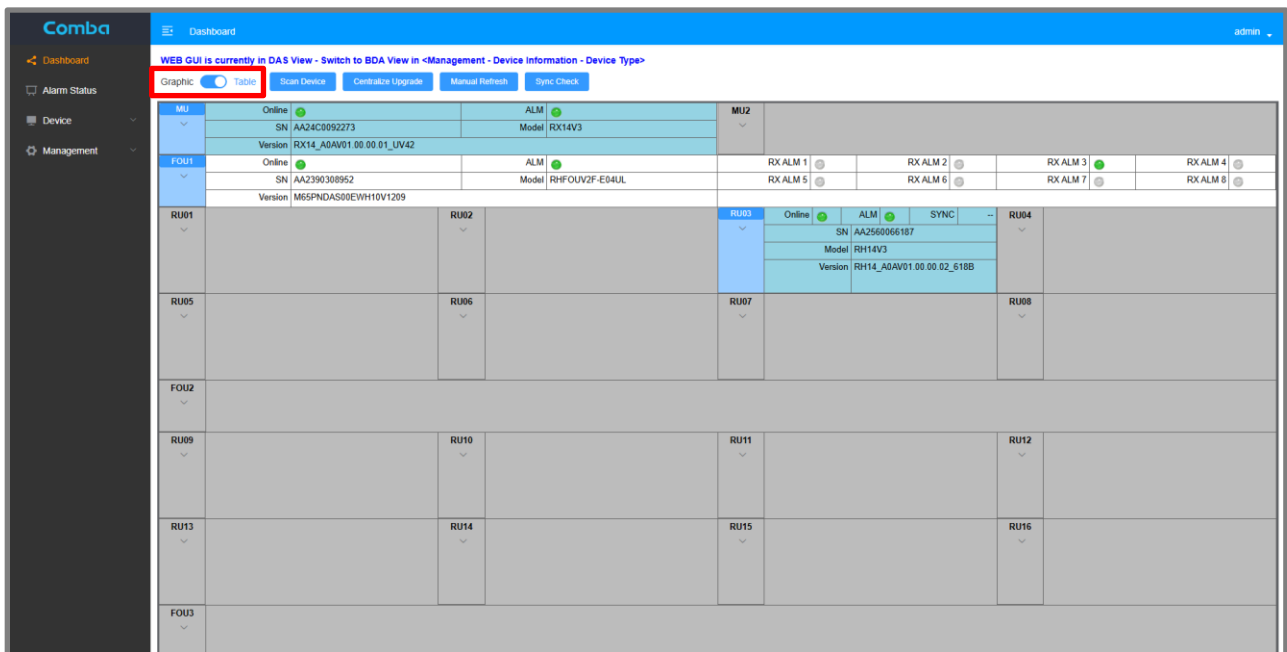

Figure 102: V3 Fiber DAS – Dashboard Table View

**Accessing Devices:**

**Accessing FOUs and RUs from Dashboard – Table View:**

In Table View, click on the device you desire to access, and the device web GUI will pop up in a new window. From this pop-up window, users can control most of the device’s operations, **except upgrading firmware**. Local connection to the device is required for direct firmware upgrade or the centralized upgrade feature must be used. Refer to section 4 for instructions on performing firmware upgrades.

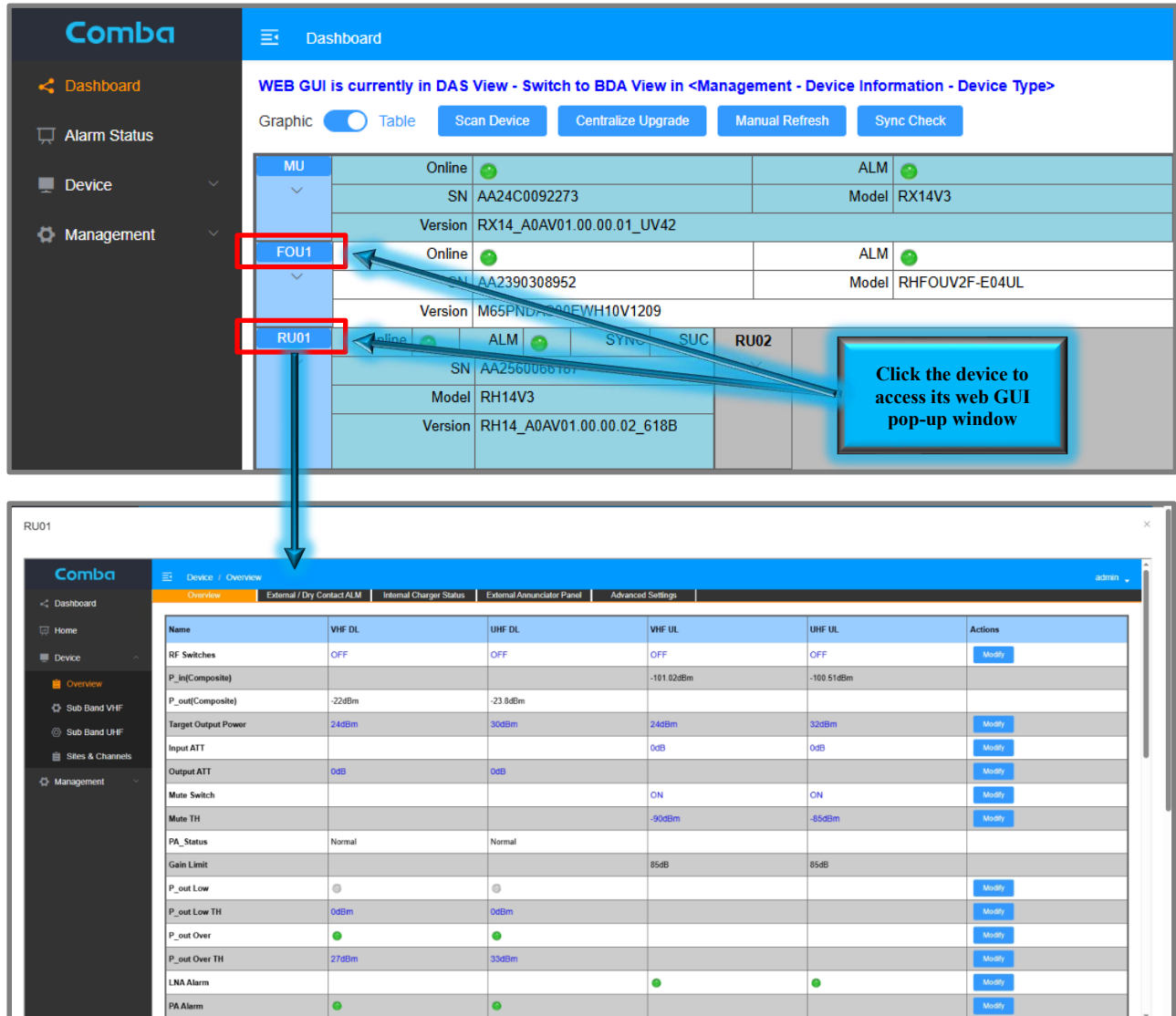

Figure 103: V3 Fiber DAS – Accessing FOUs and RUs from Dashboard Table View

Accessing FOUs and RUs from Main Menu – Home:

From the BDA Main Menu, clicking on <Home> will also allow you to access each of the devices from the device check box in the top of the window. Clicking on the device check box will take you to the device's settings. The tabs provide commonly used features. Some features are omitted such as License Management. Full functions can be found from the top bar – The View Only button is only available for a specific device.

COMING

SOON

TBD!

Name	Overview	Alarm	BBU	AP	Advanced	Channels & Sites	Device Information	Actions
Frequency Bands	DL		UL [799	UL [806, 816]		800	[1, 861]	
RF Switches			ON	ON				Modify
P_in(Composite)			<-65dBm	<-65dBm				
P_out(Composite)	<0dB					18.0dB		
Target Output Power			27dB	27dBm		33dBm		Modify
Input ATT								Modify
Output ATT	0dB					0dB		Modify
Mute Switch			ON	ON				Modify
Mute TH			-75dBm	-75dBm				Modify
PA_Status	Normal					Normal		
Gain Limit			65dB	65dB				
P_out Low								Modify
P_out Low TH								Modify
P_out Over								Modify
P_out Over TH			30dBm					Modify
LNA Alarm								Modify
PA Alarm								Modify
PA Shutdown Alarm								Modify
VSWR Alarm								Modify

Figure 104: V3 Fiber DAS – Accessing FOUs and RUs from Home screen

### 3.16 V3 BDA/MU/RU GENERAL SETTINGS

Below are some general information settings which you are recommended to change upon logging into the system for the first time.

- Login to the BDA/MU and navigate to <Management – Device Information>.
- Modify the Device Information <Dev Info> if desired. Use this field to create an ID and/or location for the device. These details appear in the main dashboard for easy viewing.
- Modify the Device Model <Dev Model> if desired. Use this field to enter the full device part number so it can be viewed through a remote connection to the web GUI. These details appear in the main dashboard for easy viewing.
- Modify the <Latitude> of the device if desired for location identification purposes.
- Modify the <Longitude> of the device if desired for location identification purposes.
- Modify the <Date/Time> if it has not been set automatically by synchronization from the laptop.
- Modify the device <IP Address>, <Netmask>, and <Gateway> as desired. Modifying this IP address only applies to the device LAN port. The device OMT port has a fixed IP address.

See Figure 105 below showing the General Information settings in the device web GUI.

The screenshot shows the Comba web GUI interface. On the left is a navigation menu with options: Dashboard, Device, Management, Device Information, Firmware Upgrade, Network, License, Tools, and User Management. The 'Management / Device Information' breadcrumb is visible at the top of the page. The main content area is titled 'Device Info' and contains a table with the following data:

Name	Value	Actions
Dev Info	Comba V3 VHF UHF BDA	Modify
Serial Num		
Dev ID	0	
Site ID	00000000	Modify
Dev Model	RXVUV3	Modify
Latitude		Modify
Longitude		Modify
Date/Time	2025-02-03 15:44:14	Modify
IP Address	192.168.1.101	Modify
Netmask	255.255.255.0	Modify
Gateway	192.168.1.1	Modify
System Version	RX14_A0A/01.00.00.01_LV34	

Figure 105: V3 BDA/MU/RU General Information Settings

### 3.17 V3 BDA/MU NETWORK IP AND SNMP SETTINGS

The user can change the IP settings and SNMP settings for the LAN port of the BDA/MU device as desired.

- Login to the BDA/MU and navigate to <Management – Network>.
- Modify the IP Settings as desired from the <IP Setting> section
- Modify the SNMP settings as desired in the <SNMP Setting> Section

The screenshot displays the Comba management interface for Network settings. The left sidebar contains navigation options: Dashboard, Device, Commissioning, Management, Device Information, Firmware Upgrade, Network (highlighted), License, Tools, and User Management. The main content area is titled 'Management / Network' and 'Parameter Direct Edit'. It is divided into two sections: 'IP Setting' and 'SNMP Setting'.

**IP Setting Table:**

Name	Value	Actions
MAC Address	00-27-1D-D3-90-4C	
IP Address	192.168.5.3	Modify
Netmask	255.255.255.0	Modify
Gateway	192.168.5.1	Modify

**SNMP Setting Table:**

Name	Value	Actions
Version	v2c	Modify
Trap Des: IP1	192.168.5.10	Modify
Trap Des: IP2	0.0.0.0	Modify
Trap Des: IP3	0.0.0.0	Modify
Port Num	161	Modify
Read Community	public	Modify
Write Community	private	Modify
SNMP Hearbeat Interval(min)	5	Modify
SNMP Hearbeat Switch	ON	Modify

Figure 106: V3 BDA/MU Network IP and SNMP Settings

### 3.18 ALARMS (DRY CONTACT / EXTERNAL ALARM / RF CONTROL)

The user can change the Dry Contact and External Alarm configuration as desired. The user can choose between one of the available default alarm configuration presets or they can customize the alarms for a specific alarm application. **Refer to the Alarm section of this User Manual for more details.**

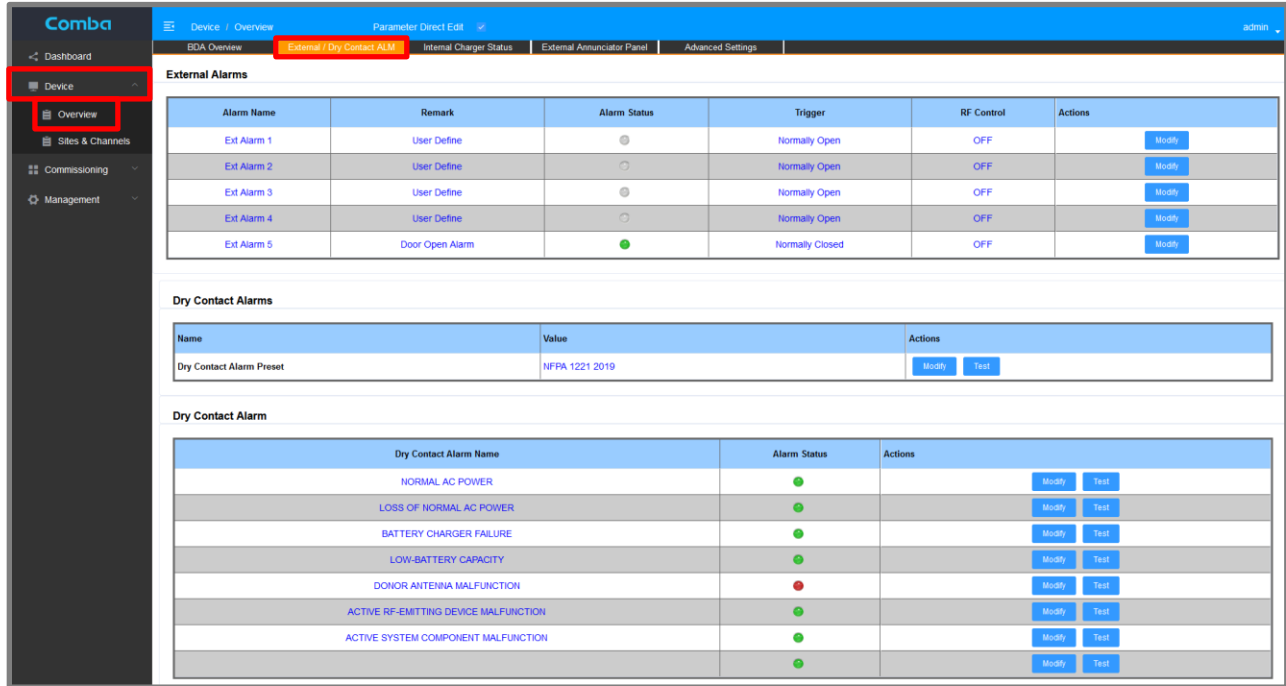

Figure 107: V3 BDA/MU/RU Dry Contact Alarms, External Alarms, and SW RF Control

#### Dry Contact Alarms (Presets):

- For BDA Mode, Login to the BDA/MU and navigate to <Device – Overview – Alarm>. For DAS Mode, Login to the BDA/MU and navigate to <Home – Device Checkbox – Alarm>.
- Click <Modify> in the <Dry Contact Alarms> section to change the configuration. Click <Save> to apply the change.

There are preconfigured dry contact alarms by different standards, as shown below: The <Test> Button next to each alarm can be used to temporarily trigger an alarm for test purposes.

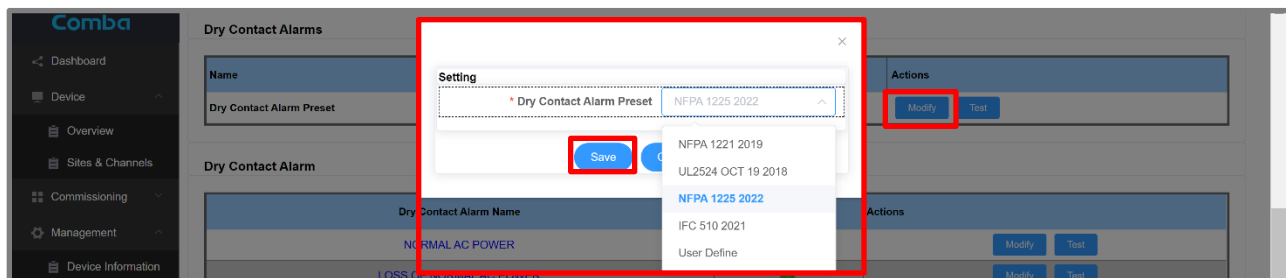

Figure 108: V3 BDA/MU/RU Dry Contact Alarm Preset Configurations

**Dry Contact Alarms (User Defined):**

Users can customize alarms and configure any BDA/DAS internal alarm to trigger any dry contact output. This is only recommended if alarm requirements do not follow one of the standard presets.

- For BDA Mode, Login to the BDA/MU and navigate to <Device – Overview – Alarm>. For DAS Mode, Login to the BDA/MU and navigate to <Home – Device Checkbox – Alarm>.
- Click <Modify> in the <Dry Contact Alarms> section to change the configuration. Select <User Defined> from the drop-down list. Click <Save> to apply the change.
- Click <Modify> in the desired Dry Contact alarm row to configure which internal BDA/DAS alarms will trigger the Dry Contact. Click <Save> to apply the change. Repeat for all desired Dry Contact Outputs.
- Install Blank Front-Panel alarm plate and label accordingly.

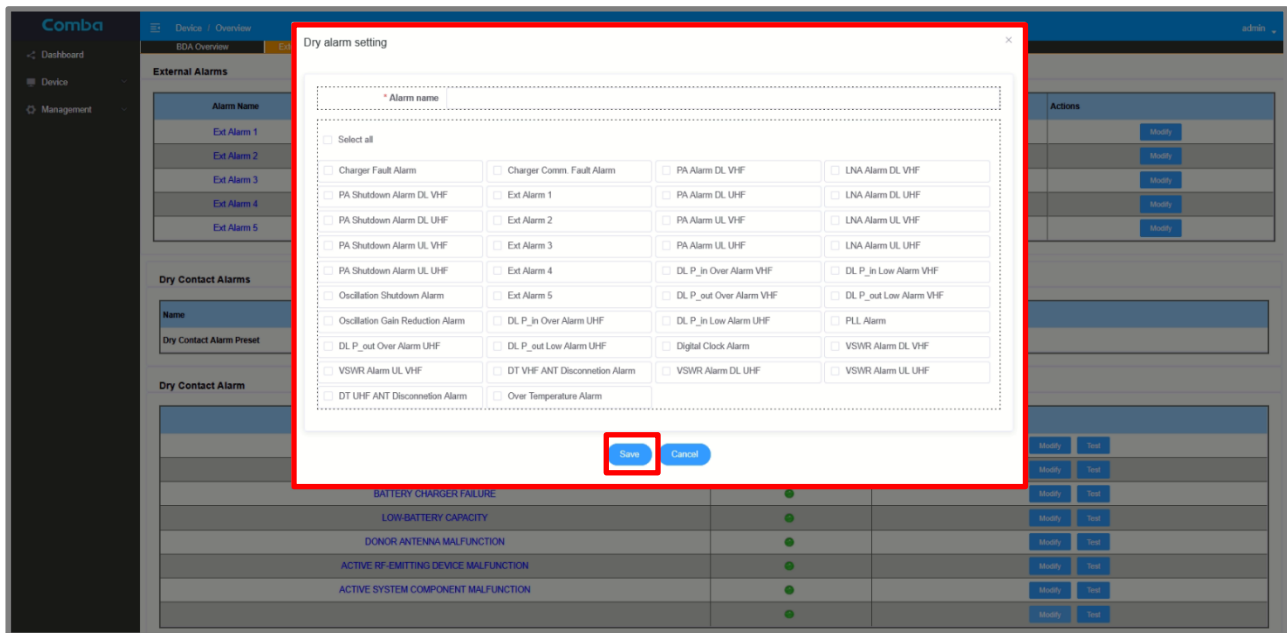

Figure 109: V3 BDA/MU/RU User-Defined/Custom Dry Contact Alarm Configuration

**External Alarms:**

A user can configure an External Alarm for an external device if desired. This allows a Dry Contact alarm from a third-party device to be monitored by the BDA/MU and can be configured to trigger one of the Dry Contact Alarm outputs. The External Alarm(s) need to be enabled for normal use and can be set to <Normally Open> / <Normally Closed> to trigger based on the external dry contact inputs configuration. From the factory, External Alarm #5 is used for <Door Open> by default, however, users can use it for other purposes if a door alarm is not required (unplug the #5 external alarm inside the BDA/DAS and configure in the software for other External alarms).

- For BDA Mode, Login to the BDA/MU and navigate to <Device – Overview – Alarm>. For DAS Mode, Login to the BDA/MU and navigate to <Home – Device Checkbox – Alarm>.
- In the External Alarm configuration section, click <Modify> for the External Alarm you wish to configure.
- In the pop-up window, configure the external alarm parameters. The user can change the <Alarm Name>, add a <Remark>, and set the <Trigger> for the External Alarm. Make sure to enable the alarm and click <Save> to apply the change.

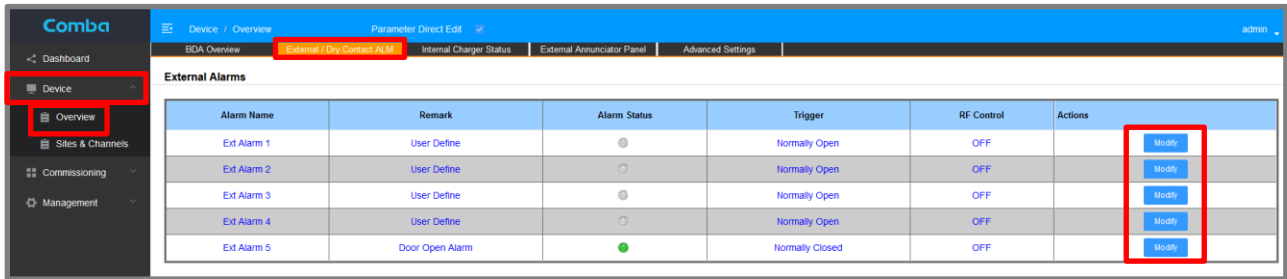

Figure 110: V3 BDA/MU/RU External Alarm Configuration

**SW RF Control:**

The user can also map one or more of the External Alarms to trigger the BDA/MU to Turn ON/OFF the RF switches for all the bands. This allows the use of a third-party device like a switch to control the RF amplification of the device.

- For BDA Mode, Login to the BDA/MU and navigate to <Device – Overview – Alarm>. For DAS Mode, Login to the BDA/MU and navigate to <Home – Device Checkbox – Alarm>.
- In the External Alarm configuration section, click <Modify> for the External Alarm you wish to configure.
- In the pop-up window, configure the external alarm parameters. The user can change the <Alarm Name>, add a <Remark>, and set the <Trigger> for the External Alarm. Make sure to enable the alarm, enable RF Control, and click <Save> to apply the change.

The alarm status will appear in the GUI (Green = No Alarm/RF switch ON, RED = Alarm/RF switch OFF) and can also be configured to trigger one or more Dry Contact Alarm outputs.

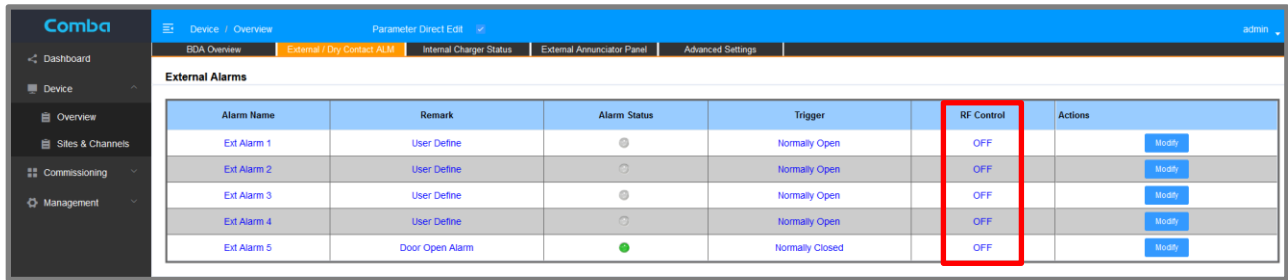

Figure 111: V3 BDA/MU/RU Software RF Control using External Alarms

### 3.19 BATTERY BACKUP UNIT

The BDA/MU/RU device must be configured properly for connection to either a Comba V3 BBU or an alternate power source. From the factory, the BDA/MU device is configured to connect to a Comba V3 BBU and the <Battery Backup Unit> parameter will be set to “Internal”. This means the device will use the internal charger to power the system and charge the batteries. If the V3 BDA/DAS is using a Comba V2 BBU or a third-party power source, the BDA/MU device must be configured accordingly, and the <Battery Backup Unit> parameter must be changed to “3rd Party OFF”.

Follow the procedure below to change the Battery Backup Unit Configuration:

- For BDA Mode, Login to the BDA/MU and navigate to <Device – Overview – Internal Charger Status – Battery Backup Unit>. For DAS Mode, Login to the BDA/MU and navigate to <Home – Device Checkbox – BBU – Battery Backup Unit>.
- Click <Modify> and change from “Internal” to “3rd Party OFF”.

When “3rd Party OFF” power source is selected, the BDA/MU turn OFF the internal charger and ignore internal device alarms related to the V3 Comba BBU.

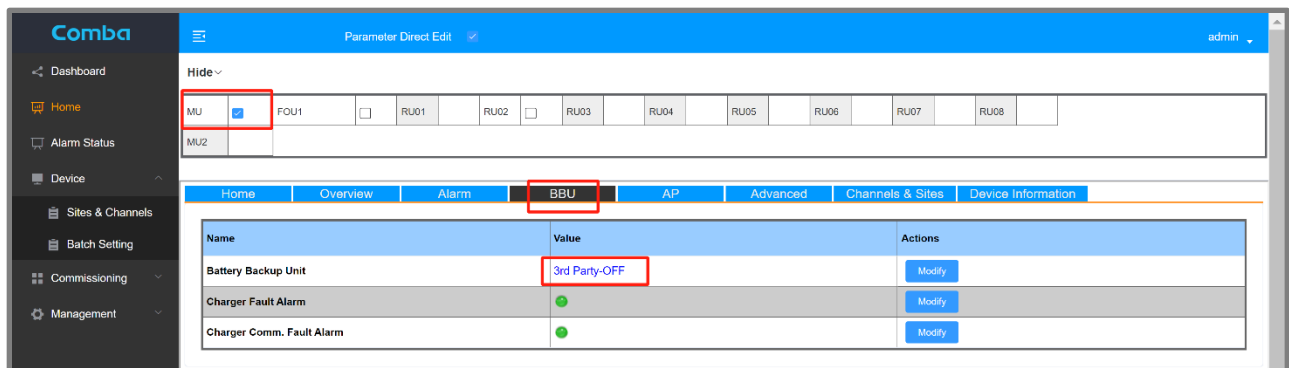
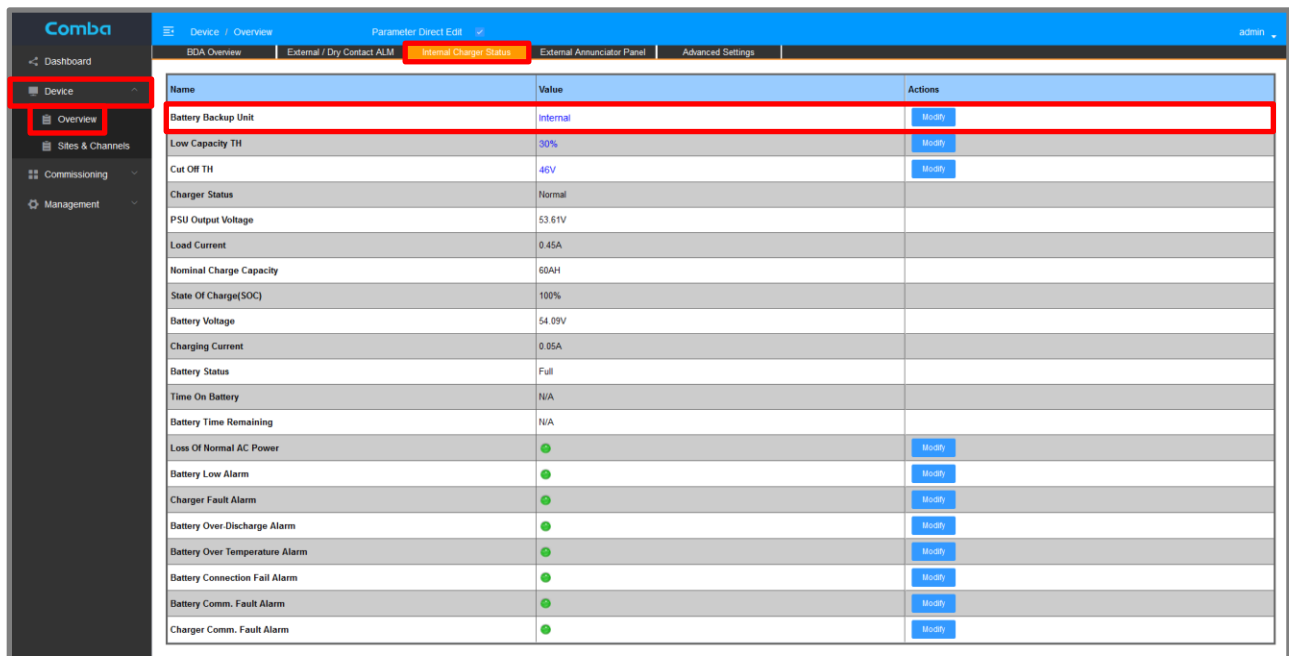

Figure 112: V3 BDA/MU/RU Battery Backup Unit Configuration

### 3.20 EXTERNAL ANNUNCIATOR PANEL COMMISSIONING PROCEDURE

Perform the following procedures to commission any Comba Annunciator Panel. The process is the same for BDA, MU, or RU.

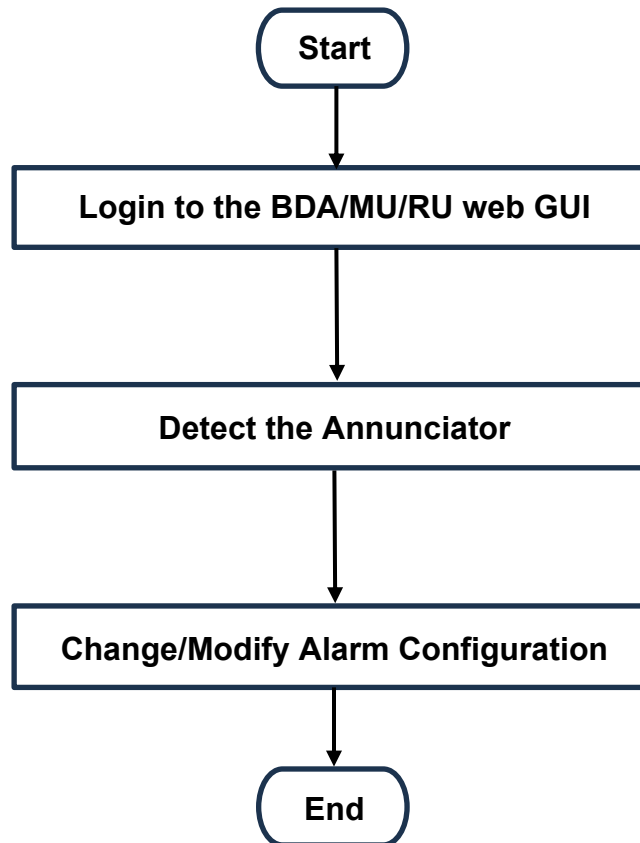

Figure 113: V3 AP Commissioning Procedure

Follow the instructions below to commission the V3 AP(s):

- Ensure all installation and wiring is complete.
- Ensure APs have been addressed accordingly. Refer to sections 2.24 and 2.25
- Login to the BDA/MU/RU web GUI.
- For BDA mode, navigate to Device -> Overview -> External Annunciator Panel. See Figure 114.
- For DAS mode, navigate to Home -> MU -> AP. For RU, Navigate through the MU to Home -> RU -> AP. See Figure 115.
- Click “detect” to start the detection process. Wait a few minutes for the AP(s) to be detected. After the AP(s) are detected, their system details will display in the GUI.
- If desired, modify alarm parameters in the “actions” column. Default settings are recommended.
- If required, change the alarm configuration to match the front panel alarm plate. See Section 3.18 for more details.

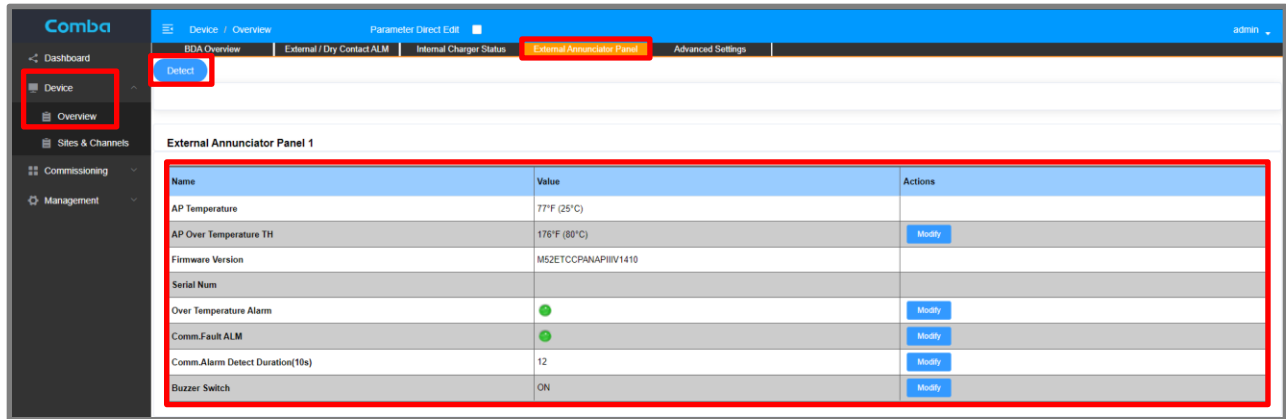

Figure 114: Commissioning V3 AP in BDA mode

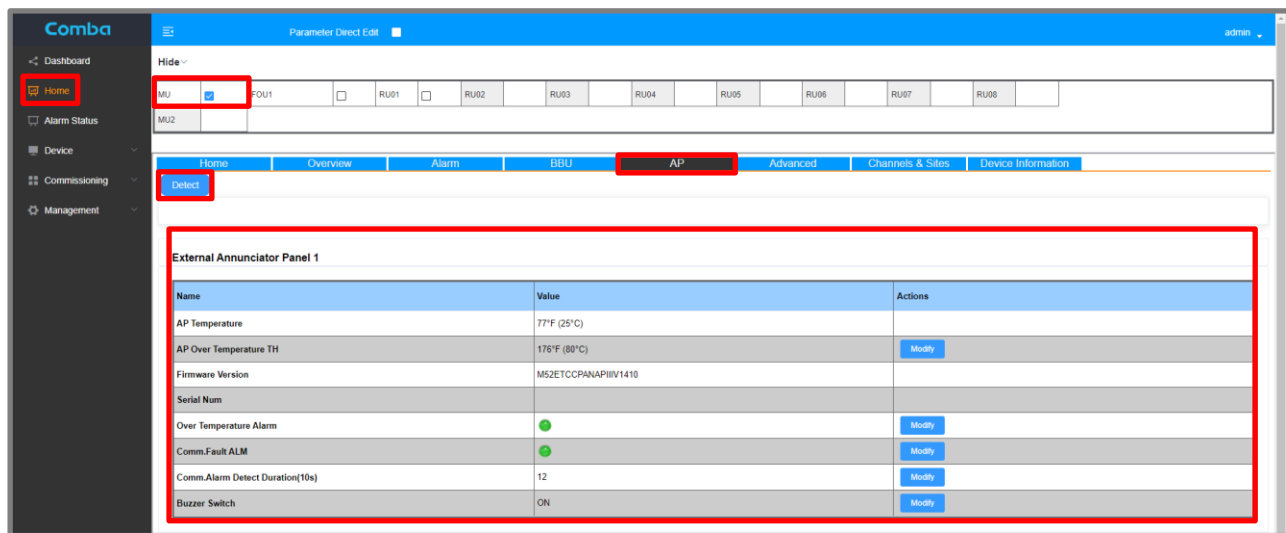

Figure 115: Commissioning V3 AP in DAS Mode

Name	Value	Actions
AP Temperature	77°F (25°C)	
AP Over Temperature TH	176°F (80°C)	Modify
Firmware Version	M52ETCCPANAPIIIIV1410	
Serial Num		
Over Temperature Alarm	●	Modify
Comm.Fault ALM	●	Modify
Comm.Alarm Detect Duration(10s)	12	Modify
Buzzer Switch	ON	Modify

Figure 116: External Annunciator Panel WEB GUI Settings

Table 17: External Annunciator Panel WEB GUI Settings Explanation

Parameter name	Description
AP Temperature	Current device temperature
AP Over Temperature Threshold	Device will alarm if above this temperature threshold. Modify if desired. Default setting recommended.
Firmware Version	Current Firmware Version loaded on the device
Serial Number	Device Serial Number
Overtemperature Alarm	Disable/Enable Overtemperature Alarm. Modify if desired. Default setting recommended.
Communication Fault Alarm	Disable/Enable Communication Fault Alarm. Modify if desired. Default setting recommended.
Communication Alarm Detection Duration(10s)	Allowable time without communication before Communication Fault Alarm. Set in Multiples of 10 seconds. The default setting is 12. 12 x 10 seconds = 120 seconds or 2 minutes
Buzzer Switch	Enable/Disable Buzzer. Modify if desired. Default setting recommended.

End of Section

### 3.21 CREATE A NEW SITE AND ADD CHANNEL FILTERS (CLASS A ONLY)

Before setting up Class A Channel Filters, a Site must be created. Creating a Site in the BDA/MU allows the user to create a group of channels filters that can be individually managed. For example, a Site can contain the Radio Channels for one donor site, or a group of test channels a user desires to use for staging purposes. If all Radio Channels will be transmitted from the same radio site with the same TX ERP, you only need to create one site. If your system requires two separate donor antennas pointed at two different Radio Systems with different characteristics, it is recommended to create a Site for each different Radio System. This allows individual control of BDA channel parameters for each Radio System.

#### **Create a New Site (Class A Configurations Only; Same for BDA and DAS mode):**

Follow the procedure below to create a new Site:

- Navigate to the <Device – Sites & Channels> page.
- Click <Add Site>. A pop-up window will appear.
- Enter the <Site Name>, the <Site Address>, and the <System Type> (Example: Site Name: Tower Site 1; Site Address: 123 ABC Street; System Type: P25 Phase 2)
- Click <Save>
- A new tab will be created in the <Sites & Channels> page to access the Site Channel Filter Setup.

The figure consists of three screenshots from the Comba V3 BDA/MU interface, illustrating the process of creating a new site. Red boxes highlight key elements, and blue arrows indicate the flow of the process.

**Top Screenshot:** The 'Site Management' page is shown. The left sidebar has 'Device' and 'Sites & Channels' highlighted. The main content area has 'Export' and 'Import' buttons. Below them is an 'Actions' section with 'No Data'. The 'Add Site' button is highlighted in the bottom right corner.

**Middle Screenshot:** The 'Add Site' pop-up form is displayed. It contains three input fields: '\* Site Name' (VHF Donor Site 1), '\* Site Address' (123 ABC Road), and '\* System Type' (Analog Conventional). 'Save' and 'Cancel' buttons are at the bottom. A blue arrow points from the 'Add Site' button in the top screenshot to this form.

**Bottom Screenshot:** The 'Site Management' page now shows a table of sites. The 'Add Site' button is highlighted. The table has the following data:

NO	Site Name	Site Address	System Type	Create Time	Actions
1	VHF Donor Site 1	123 ABC Road	Analog Conventional	2025-02-03 15:39:29	Modify Delete
2	UHF Donor Site 1	123 DEF Road	P25 Phase 1	2025-02-03 15:39:53	Modify Delete

Figure 117: V3 BDA/MU Creating a New Site

**Adding Channel Filters (Same for BDA and DAS mode):**

Once a new Site has been created, a new tab will appear on the BDA/MU <Sites & Channels> page.

- Click on the Site Tab to configure Class A Channel Filters for both VHF and UHF bands.
- Click on <Add Channels> for a specific band to add the channel filters for that band.
- Enter the <Number of Filters> required and the desired Filter BW <Filter>. Click <Save>.
- Repeat for both bands if applicable.
- Note: The DL Frequencies <DL Freq> will not be set at this time and will be modified in later step.

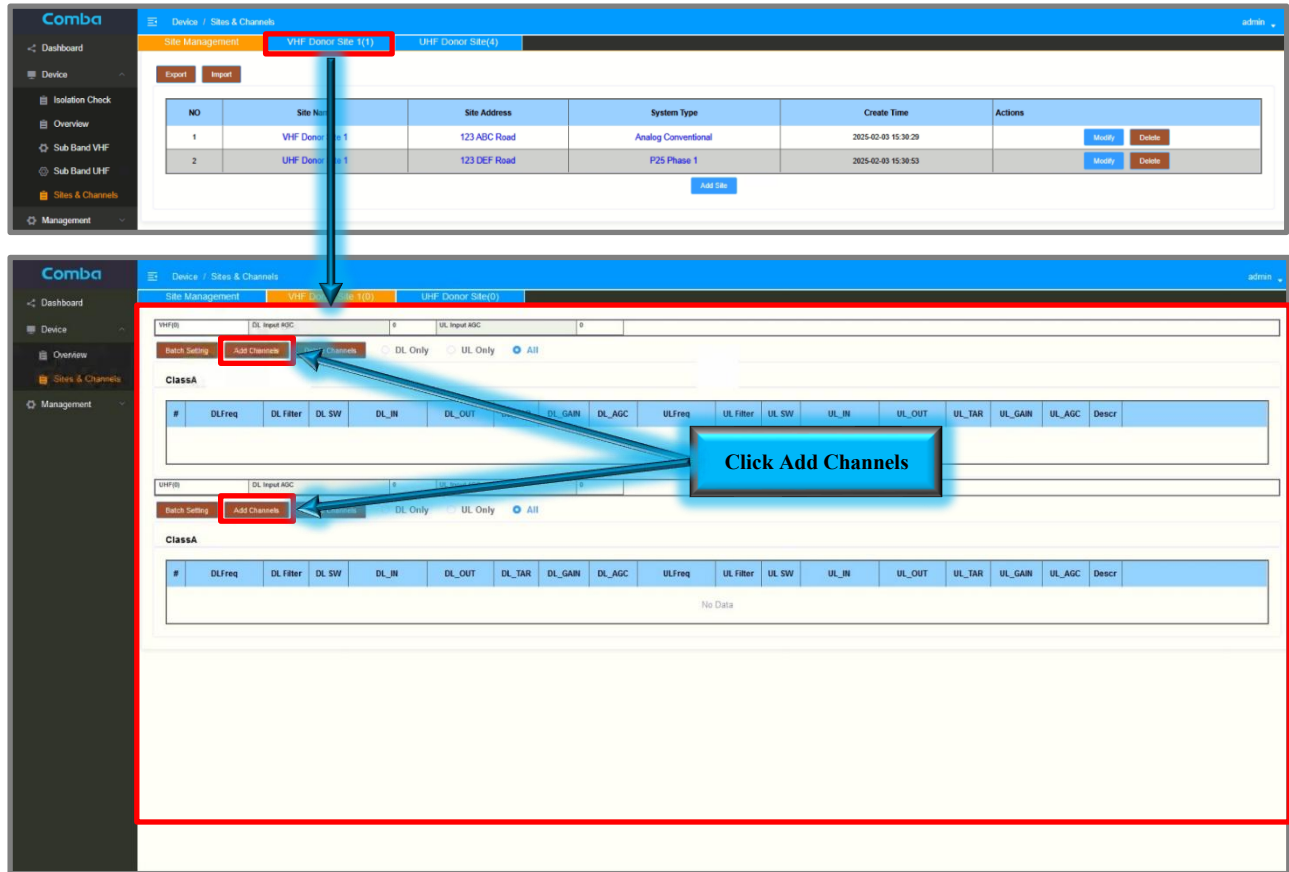

Figure 118: V3 BDA/MU Adding Channel Filters (Class A Only)

**Deleting Channel Filters (Same for BDA and DAS mode):**

The user can delete channel filters if desired.

- Click on the Site Tab to delete Class A Channel Filters for both VHF and UHF bands.
- Click on <Delete Channels> for a specific band to delete the channel filters for that band.
- Enter the Filter Start Number <Start No.> and the Filter End Number <End No.> to be deleted. In the below Figure 1194 example, Channel Filters 5 – 10 will be deleted.
- Repeat for both bands if applicable.

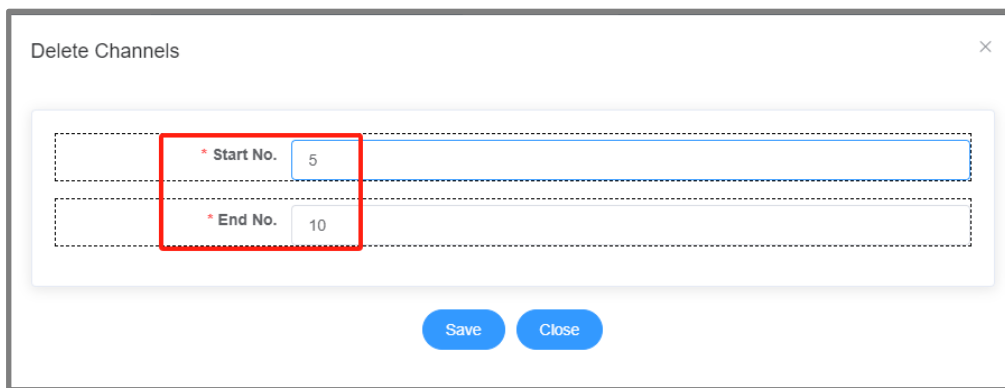
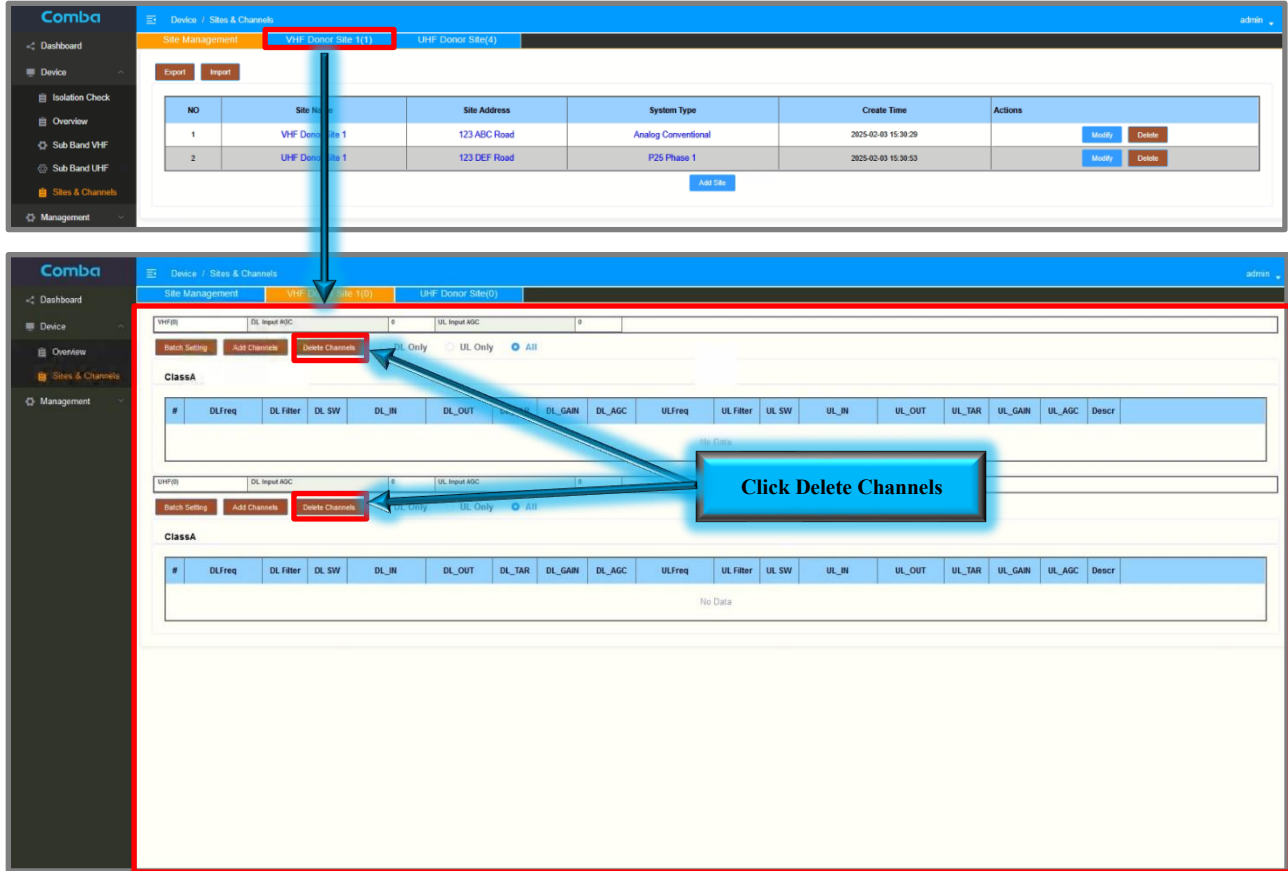

Figure 119: V3 BDA/MU Deleting Channel Filters (Class A Only)

**Setting Channel Filter Frequency (Same for BDA and DAS mode):**

The user must set the center frequency for each Channel Filter that has been configured.

- Click on the specific DL Frequency <DL Freq> that you want to set.
- Enter the Channel Center Frequency in the pop-up window. Click <Save>. Repeat for all Channel Filters for each applicable band.
- If applicable, assign the Control Channel for each band by clicking on the “Dash” in the <Desc> control channel frequency column. Select <Control> from the dropdown list and click <Save>.

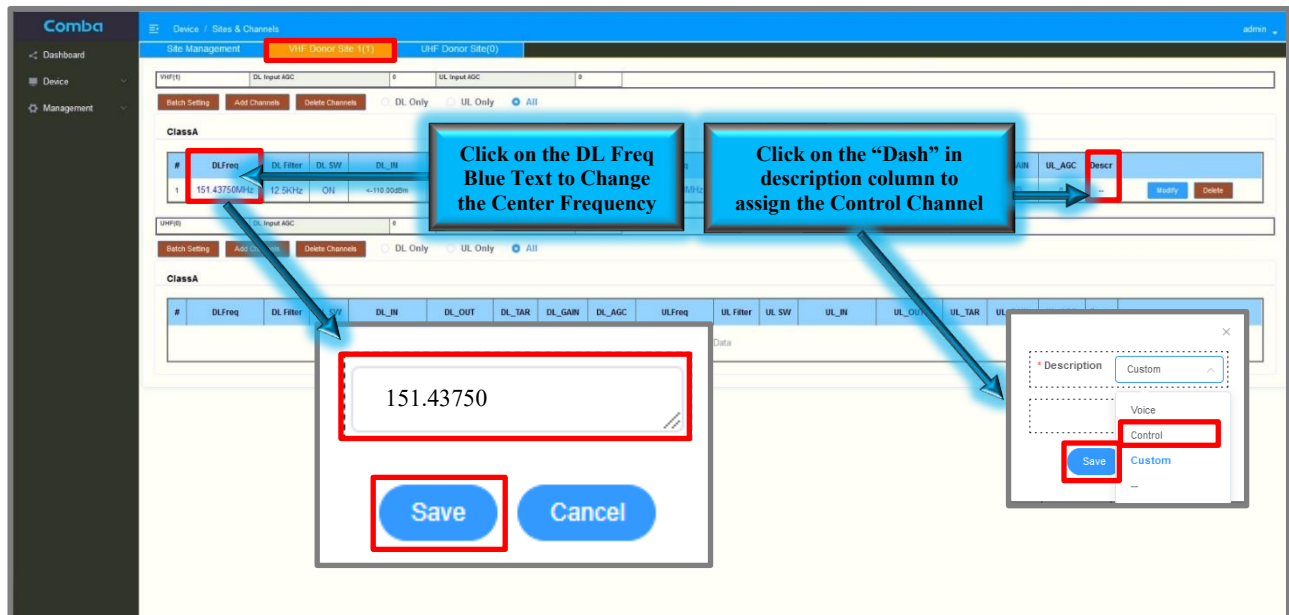

Figure 120: V3 BDA/MU Setting Channel Filter Frequencies (Class A Only)

### 3.22 CREATE SUB-BAND FILTERS (CLASS B ONLY)

If the device is to be used in a Class B filter configuration, the user will need to configure the Sub-Band Filter(s) for each band. The user can set up to 3, non-overlapping Sub-Band Filters to provide Band-Selective Amplification over the desired frequency range(s).

- Navigate to <Device – Sub Band XXXMHz> for the frequency band you desire to setup.
- Click <Modify> for the Sub Band you wish to configure.
- Set the Start <DL Freq Low (MHz)> and Stop <DL Freq High (MHz)> Frequency for the Sub Band Filter. Click <Save>.
- Note: DL/UL ALC (MAX Sub-Band Filter Power Level) and DL/UL Gain levels can be set at this time if they are known from System Design or Technician Measurements.

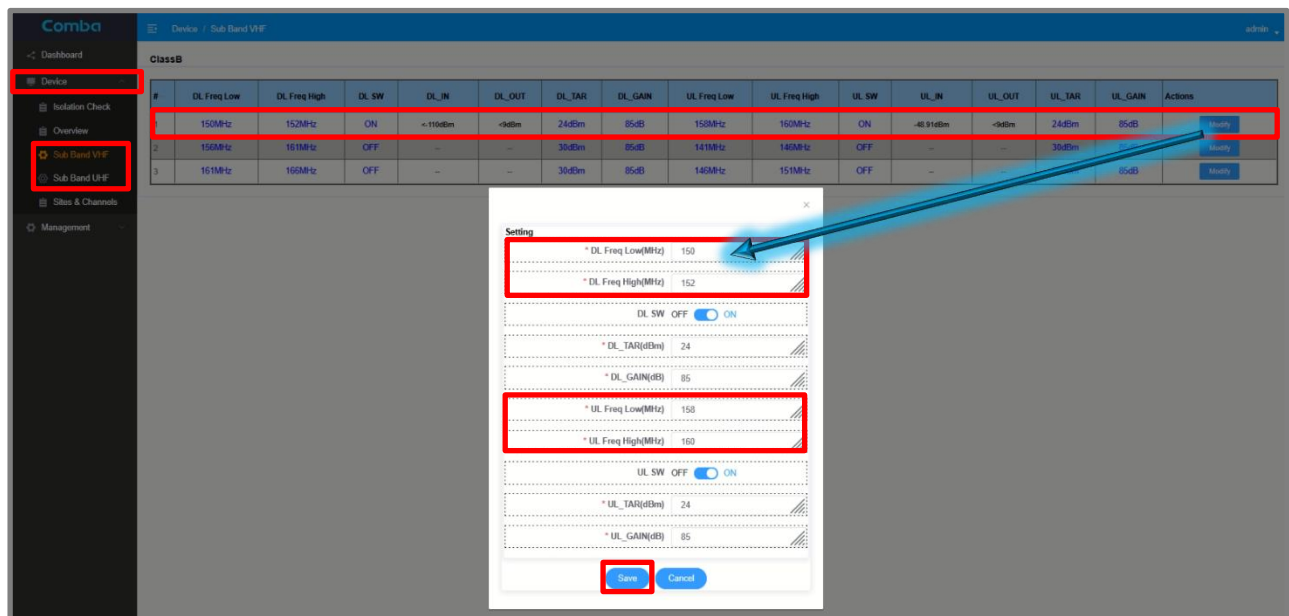

Figure 121: V3 BDA/MU Create Sub-Band Filters (Class B Only)

### 3.23 COMMISSIONING TOOLS – DL INPUT TEST (CLASS A BDA ONLY)

The DL Input Test is a commissioning tool provided to assist users with estimating commissioning parameters. The user can perform a <DL Input Test> to measure the signal strength of the configured DL control channel received from the BDA/BBU. The measured signal strength is then used in calculations to estimate DL Pathloss and DL Gain setting. This is an optional tool, and the technician can perform a Manual Override measurement and enter the test results if this is preferred.

#### DL Input Test (DL Commissioning Tool)

- Ensure a Control Channel has been assigned. The DL Input Test only works if there is an active Control Channel. The selected Control Channels will appear in the drop-down list in the DL Input Test section. See section 3.21 Setting Channel Filter Frequency.
- Navigate to <Commissioning –> <DL Input Test>.
- Select the “Site” that you want to commission by checking the corresponding checkbox.
- Select the Control Channel from the drop-down menu.
- Select the <Test Duration>. The test power level will be measured during this duration.
- Click <Test>. Wait until the test is completed.
- Complete a <DL Input Test> for each site if there are more than one.

The results will be displayed in the top window in the <Control Channel Input (dBm) section highlighted in green. The results will also be displayed in the <Commissioning –> <DL Input Test> table when you navigate to <Device –> <Sites & Channels –> <Site>. The results can be used later to generate estimated RF parameters.

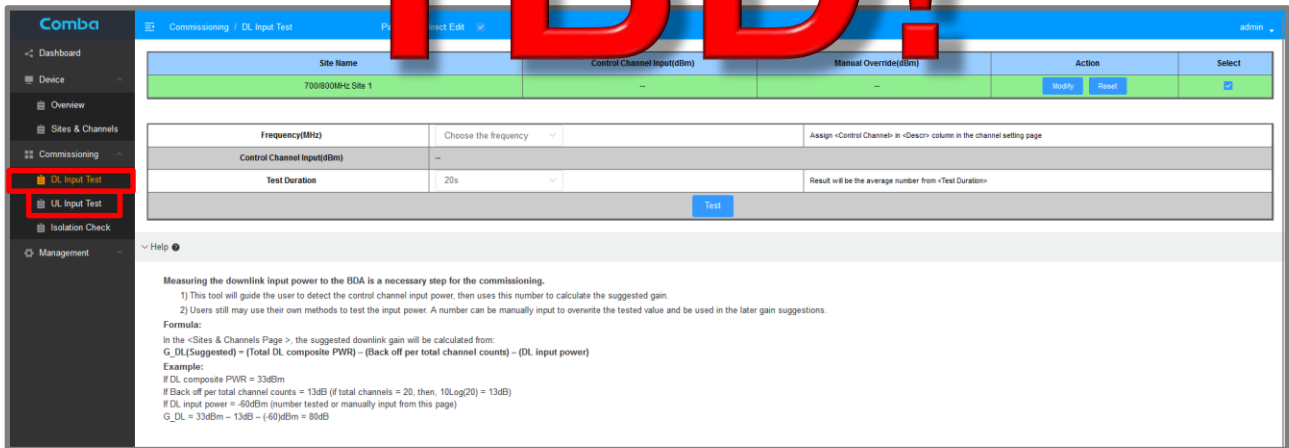

Figure 122: V3 BDA/MU Commissioning Tools – DL Input Test



Figure 123: V3 BDA/MU Commissioning Tools – Performing DL Input Test

**DL Input Test (Manual Measurement):**

- Select the Site and select Control Channel from the drop-down list.
- Click <Modify>, Select <Manual Override> from the drop-down, enter your Measured DL Input Level in dBm, and click <Submit>. Results will display in <Manual Override (dBm)> section of top window.

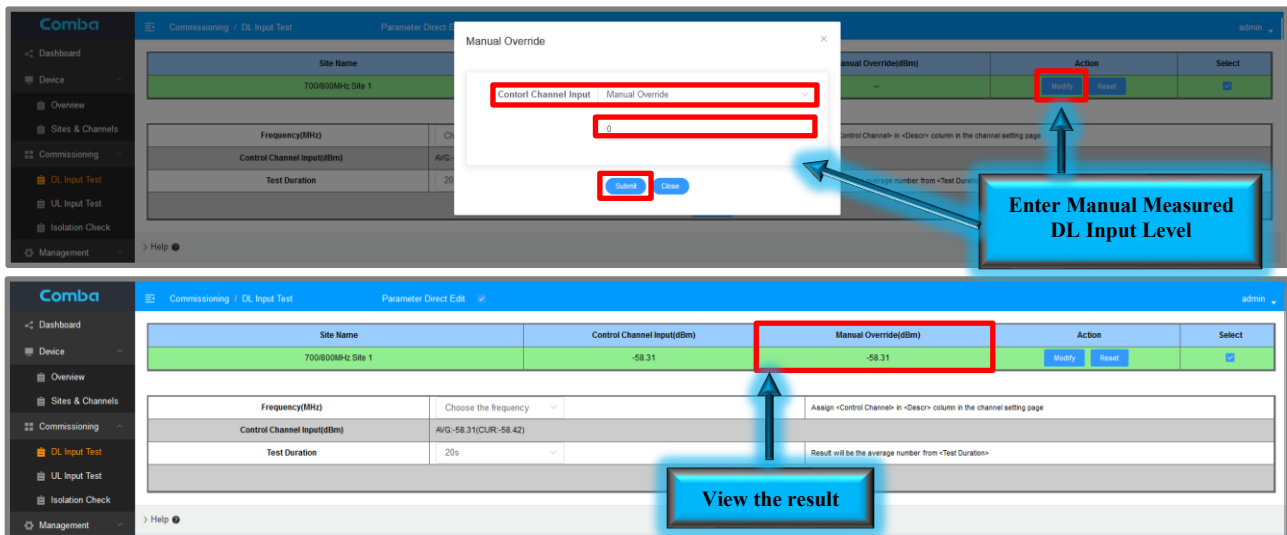

Figure 124: V3 BDA/MU Commissioning Tools – DL Input Test Manual Override

### 3.24 COMMISSIONING TOOLS – UL INPUT TEST (CLASS A BDA ONLY)

The UL Input Test is a commissioning tool provided to assist users with estimating commissioning parameters. The user can perform <UL Input Test> to help determine the minimum uplink power range the BDA/MU will see at its Mobile Terminal from radios throughout the coverage area. The measurement is then used in calculations to estimate the minimum UL Gain and Minimum Target Receive Level that can be used. This is an optional tool and the technician can perform an antenna Override measurement and enter the result instead if the tool is preferred.

**Required Test Equipment:** Signal Generator or a Calibrated Portable Radio; Whip Antenna

**UL Input Test (GUI Commissioning Tool):**

- Prepare a Signal Generator w/Whip Antenna or Calibrated Portable Radio for the test.

If you use a Signal Generator with a whip antenna use a CW tone for this test. The frequency will need to be set in the same uplink range as the BDA passband will determine. You must use the TX Power Level higher than -10dBm for the best results.

If using a Calibrated Portable Radio, determine the radio frequency and set a fixed frequency for when it keys up. If the radio only shows the downlink frequencies, below are the conversion formulas between downlink and uplink frequencies for the UHF band. The VHF band does not have a standard duplex spacing.

UHF (450-470MHz): UL frequency = DL frequency + 5MHz, e.g., DL Freq = 451MHz, UL Freq = 456MHz

UHF (470-512MHz): UL frequency = DL frequency + 5MHz, e.g. DL Freq = 472MHz, UL Freq = 475MHz

- Navigate to <Commissioning – UL Input Test>
- Select the “Site” that you want to commission
- Click <Modify> in the Site “Action” column. A pop-up window will appear. Ensure <Device Measurement> is selected. Enter the actual <Radio TX PWR> in dBm of the radios that will be used for the jurisdiction and click <Submit>. This information must be filled in for each donor site so the system can apply an offset (between the actual radios and device used during the test) to calculate the uplink input range from the actual radios.
- <Modify> and set the <UL Input Freq (MHz)> to use for the test.
- <Modify> and set the <Test Device TX Power (dBm)> to use for the test.
- <Modify> and set the <UL min. Input TH dBm)> to use for the test.

The <UL min Input TH> parameter in the testing table is used to prevent the case that the signal generator or portable radio turns off during the test and ‘no input’ will be recorded as ‘min input’ by mistake. The threshold can be set to any number between the min input (if this can be estimated from the design) and the noise floor. Otherwise, just use the default value of -110dBm.

See Figures 125 and 126 below.



Figure 125: V3 BDA/MU Commissioning Tools – UL Input Test

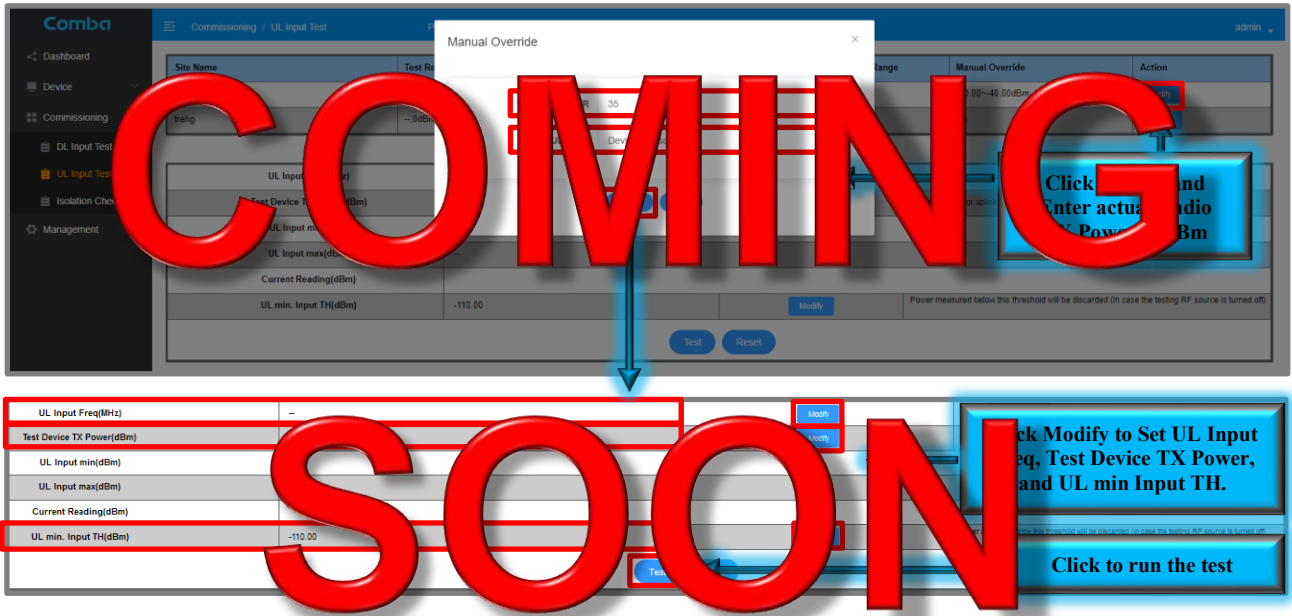

Figure 126: V3 BDA/MU Commissioning Tools – Performing UL Input Test

- Click the <Test> button to begin the test. The test will continue to run indefinitely.

The user can now walk through the coverage area performing transmissions so the system can detect the minimum input and maximum input to the BDA. If you use a Signal Generator, leave the device transmitting a CW tone throughout the entire link. If using a portable radio, ensure you make transmissions close to antennas and far from antennas (Near and Far locations). The goal of the test is to capture the strongest and the weakest signals the BDA will see.

- When you have completed the test and the measurements are done, click on <Click here to stop the test> button to end the test. A pop-up window will appear and ask, “should the current test result be adopted?”. Click <OK> if you are satisfied with the test results and want to save the measurements. If you do not want to save the measurements, click <Cancel>.
- You can reset the measurements at any time by clicking on <Reset>.

**Note: Any abnormal exit while performing the UL Input Test will require the user to power-cycle the device for the BDA to exit the UL Input Test monitoring mode.**

The results will be displayed in the top window in the <Uplink Input Range> section. The results will also be displayed in the <Commissioning Tool> table when you navigate to <Device – Sites & Channels – Site>. The result can be used later to generate estimated RF parameters. See Figure 127 below.



Figure 127: V3 BDA/MU Commissioning Tools – UL Input Test Results

**UL Input Test (Manual Measurement):**

- Navigate to <Commissioning> - UL Input Test>
- Select the site that you want to commission
- Click <Modify> in the Site "Action" column. A pop up window will appear. Select <Manual Override>. Enter the actual <Radio TX Power> (W/F) in dBm. The radio power will be used for judgment. This information must be filled in for each tower the software system can apply an offset (between actual radio device power during the test) to calculate the uplink input range from the actual radios.
- Enter the Manual Measurements for <Input Min (dBm)> and <Input MAX (dBm)> and click <Submit>. Results will display in the <Manual Override> section of the top window.

**COMING**



**SOON**

**TBD!**

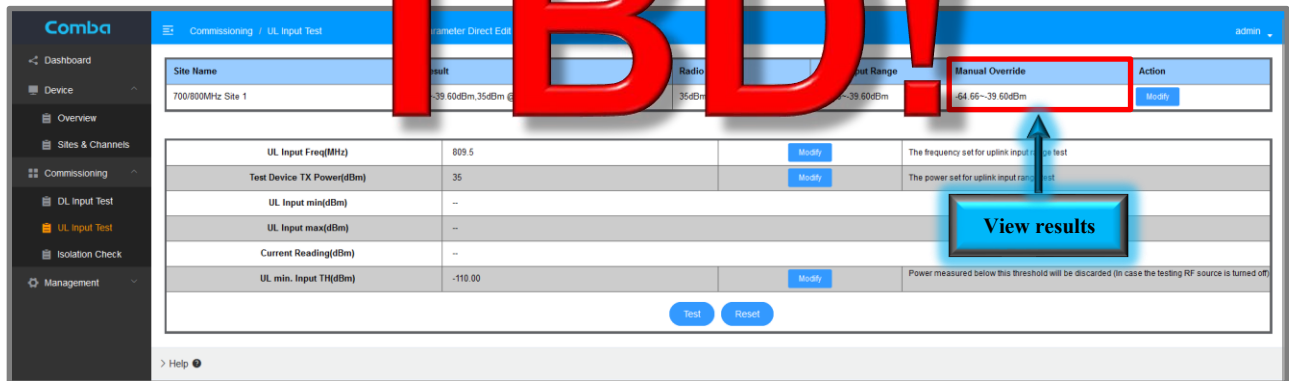

Figure 128: V3 BDA/MU Commissioning Tools – UL Input Test Manual Override

### 3.25 COMMISSIONING TOOLS – ISOLATION CHECK

The Isolation Check is a commissioning tool provided to assist users with estimating commissioning parameters. The user can perform a <Isolation Check> to have the GUI measure the Isolation between the Donor Antenna Branch (Donor Terminal) and the Indoor Antenna Branch (Mobile Terminal). The measurement is then used to limit the Maximum DL/UL Gain of the BDA to prevent oscillation and meet code requirements. This is an optional tool, and the technician can perform a Manual Override measurement and enter the result instead if that is preferred.

The BDA is configured to provide the user with the ability to choose VHF and UHF frequencies to test the isolation across the desired passband. The user can run the Isolation Check using a single test frequency or multiple test frequencies in the passband. The device will begin by performing measurements on the DT port of the device to see if there is any power detected on the test frequencies that have been selected. If there is power detected on a test frequency above the <Noise Floor TH(Isolation Test)> which is set, that test will be skipped as the results will not be accurate. If the device does not measure any power on the test frequency, it will move forward with performing the Isolation Measurement for that frequency.

#### Isolation Check (GUI Commissioning Tool):

- Set the <Noise Floor TH(Isolation Test)> parameter. The <Noise Floor TH(Isolation Test)> can be found and set in the <Device – Overview – Advanced Settings> page. This parameter should be set above the actual measured UL Noise Floor (10KHz Resolution Bandwidth) measured at the BDA Mobile Terminal. If unable to perform this measurement, leave at the default setting of -85dBm.
- Navigate to <Commissioning Tools – Isolation Check>
- Ensure the Isolation Measurement type is set to “Auto” in the <Use manual or auto> section.
- Set the test frequencies to be used for each band.

**Note: Test frequencies should not be set to actual radio channel frequencies (Including neighboring radio sites/channels)! Use vacant frequencies that land between actual DL radio channels to avoid false measurements!**

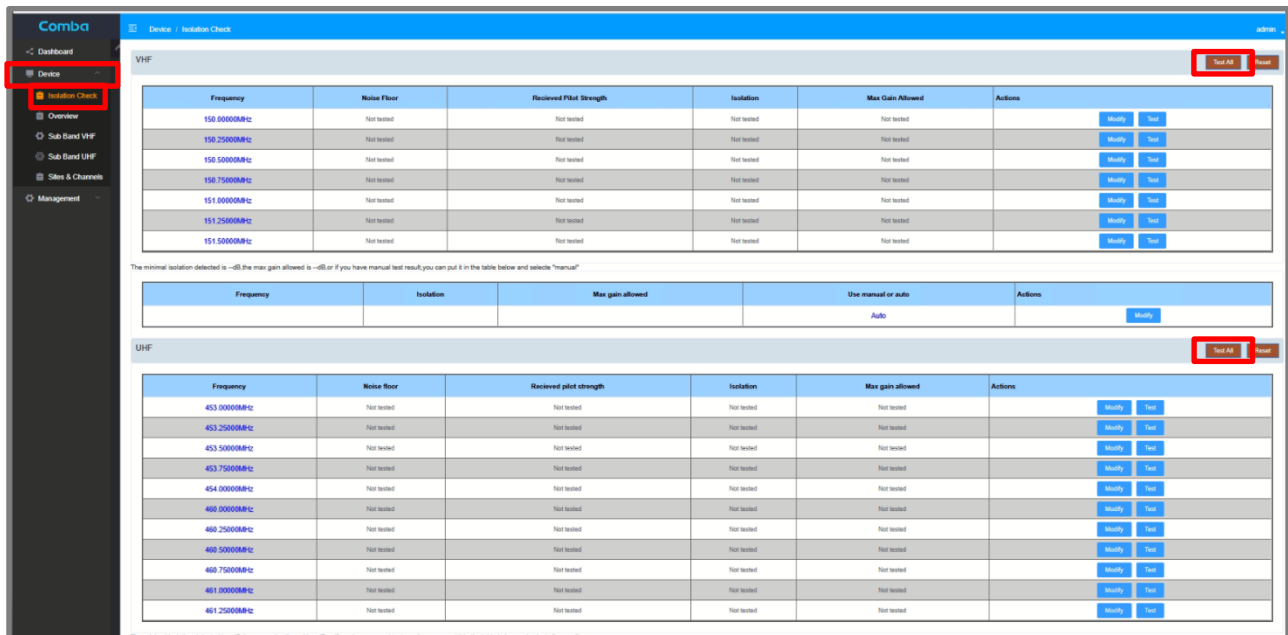

Figure 129: V3 BDA/MU Commissioning Tools – Isolation Check

- Click <Test All> to run a test on all the test frequencies for that band. Click <Test> for a specific frequency to test isolation for that specific frequency only. Wait for all tests to be completed.

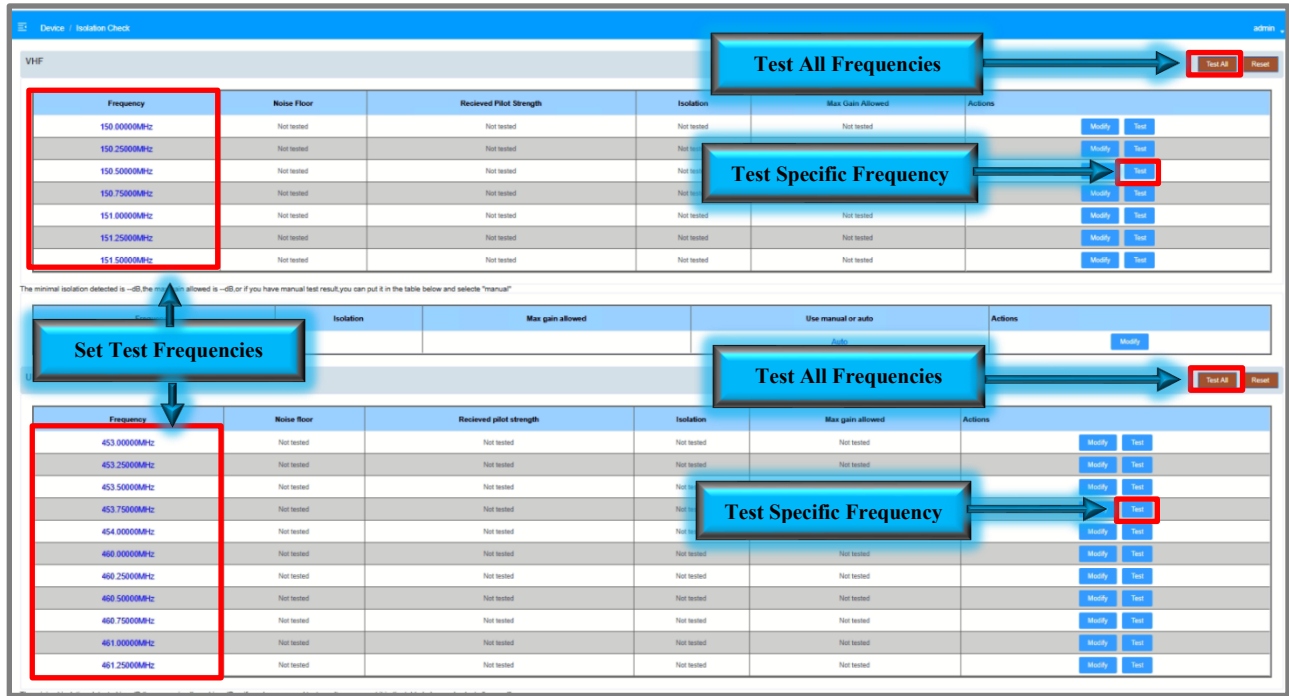

Figure 130: V3 BDA/MU Commissioning Tools – Performing Isolation Check

During the test, the device will generate a +10dBm tone out of the Mobile Terminal on each of the test frequencies, then measure the received power at the Donor Terminal. The difference between the generated signal power and the received signal is the resultant Isolation.

Example:

$$\text{Isolation} = \text{Generated Signal Power} - \text{Received Signal Power} = +10\text{dBm} - (-85\text{dBm}) = 95\text{dB}$$

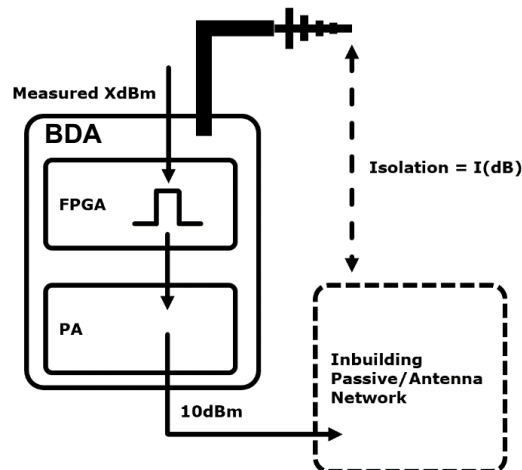

Figure 131: Commissioning Tools – Isolation Check Diagram

The test results will be displayed for each test frequency for each band. The results will also be displayed in the <Commissioning Tool> table when you navigate to <Device – Sites & Channels – Site>. The device will use the Lowest Isolation measured for each band to limit the BDA Gains according to the code requirement to provide 20dB margin between BDA Gain and Isolation.

- You can reset the measurements at any time by clicking on <Reset>.

Example (See Figure 132 below): Lowest Isolation Measured: 100dB  
 MAX BDA Gain = Isolation - 20dB = 100dB - 20dB = 80dB

Frequency	Noise Floor	Received Pilot Strength	Isolation	Max Gain Allowed	Actions
150.00000MHz	-120dBm	-92	102	80	Modify Test
150.25000MHz	-120dBm	-90	100	80	Modify Test
150.50000MHz	-120dBm	-90	100	80	Modify Test
150.75000MHz	-120dBm	-90	100	80	Modify Test
151.00000MHz	-120dBm	-91	101	80	Modify Test
151.25000MHz	-120dBm	-91	101	80	Modify Test
151.50000MHz	-120dBm	-92	102	80	Modify Test

Figure 132: V3 BDA/MU Commissioning Tools – Isolation Check Results

**Isolation Check (Manual Measurement):**

- Navigate to <Commissioning Tools – Isolation Check>
- Ensure the Isolation Measurement type is set to “Manual” in the <Use manual or auto> section.
- Enter your manual Isolation Measurement in the <Isolation (dB)> section. Click <Save>. Results will display in the window below each band’s test frequency section. See Figure 133 below.

The minimal isolation detected is 100dB, the max gain allowed is 80dB, or if you have manual test result, you can put it in the table below and select "manual"

Frequency	Isolation	Max gain allowed	Use manual or auto	Actions
150.00000MHz			Auto	Modify
150.25000MHz			Auto	Modify
150.50000MHz			Auto	Modify
150.75000MHz			Auto	Modify
151.00000MHz			Auto	Modify
151.25000MHz			Auto	Modify
151.50000MHz			Auto	Modify

Setting

- \* Frequency(MHz) 151.25
- \* Isolation(dB) 120
- \* Use manual or auto  Auto  Manual

The minimal isolation detected is -dB, the max gain allowed is -dB, or if you have manual test result, you can put it in the table below and select "manual"

Frequency	Isolation	Max gain allowed	Use manual or auto	Actions
151.25000MHz	120dB	85dB	Manual	Modify

Figure 133: V3 BDA/MU Commissioning Tools – Isolation Check Manual Override

### Performing a Manual Isolation Test

The isolation between BDA Donor Antenna and In-Building Services Antenna determines the maximum downlink gain or uplink gain. It is required that the **Gain (Set in the BDA) <= Isolation - 20**

Follow the instructions below for the recommended isolation test setup:

1. Disconnect the Donor Antenna feedline cable from the DT Port of BDA and the Service Antenna feedline cable from the MT port of the BDA.
2. Connect a Signal Generator to the Service Antenna feedline cable. It's not recommended for the Signal Generator to be used on the DT side, as it could cause interference with outdoor radio networks.
3. Connect a Spectrum Analyzer to the Donor Antenna feedline cable.
4. If using a CW tone for the test, pick a frequency to use for the test. Before the CW turns on, make sure there is no other signal on this frequency seen on the Spectrum Analyzer. After this is set up, turn on the CW, and measure the level on the Spectrum Analyzer. The output level from Signal Generator is represented by  $X\_T$ (dBm) and the received power from the Spectrum Analyzer is represented as  $X\_R$ (dBm). The isolation is calculated as:

$$I(\text{dB}) = X\_T - X\_R$$

For example:

$$X\_T = 10\text{dBm}, X\_R = -95\text{dBm}$$

$$I = 10 - (-95) = 105\text{dB}$$

It is recommended to generate a minimum of 3 frequencies at low, mid, and high at each passband for the test, including the uplink band. For example: 450MHz, 451MHz, 452MHz, 453MHz, 455MHz, 456MHz, 457MHz, 458MHz, 459MHz.

**Note: Using a tracking Generator can observe the entire passband and provides the most accurate value of Isolation. It is preferred. The isolation can be calculated from the <output power – received power>**

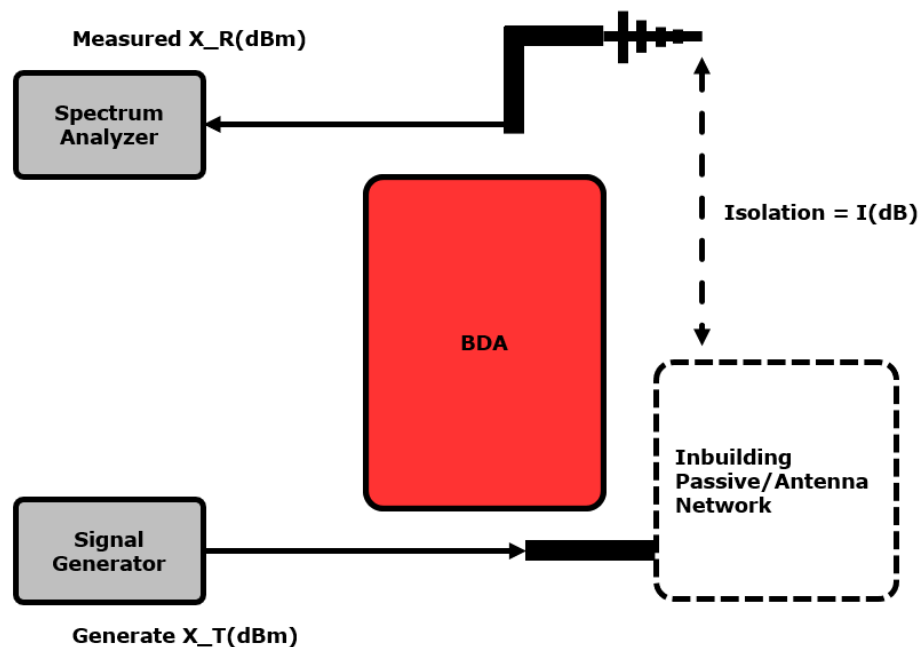

Figure 134: Commissioning Tools – Isolation Check - Performing a Manual Isolation Test

**Isolation Check Automatic Filter Switch Turn Off Protection:**

After the Isolation Check has been completed, if there are any filters currently using a higher gain than the MAX Allowed (> Isolation - 20) and the RF SW is ON, the **BDA will prompt the user to switch off the filter (but will not change the previous gain setting)**. The gain check will occur again when users try to switch ON the filters. The user must first select <Close RF Switch> in the pop-up window to temporarily turn OFF the RF Switches. The user must then lower the gain below the MAX Allowed to turn the Filter SW back on for that filter. See Figure 135 below.

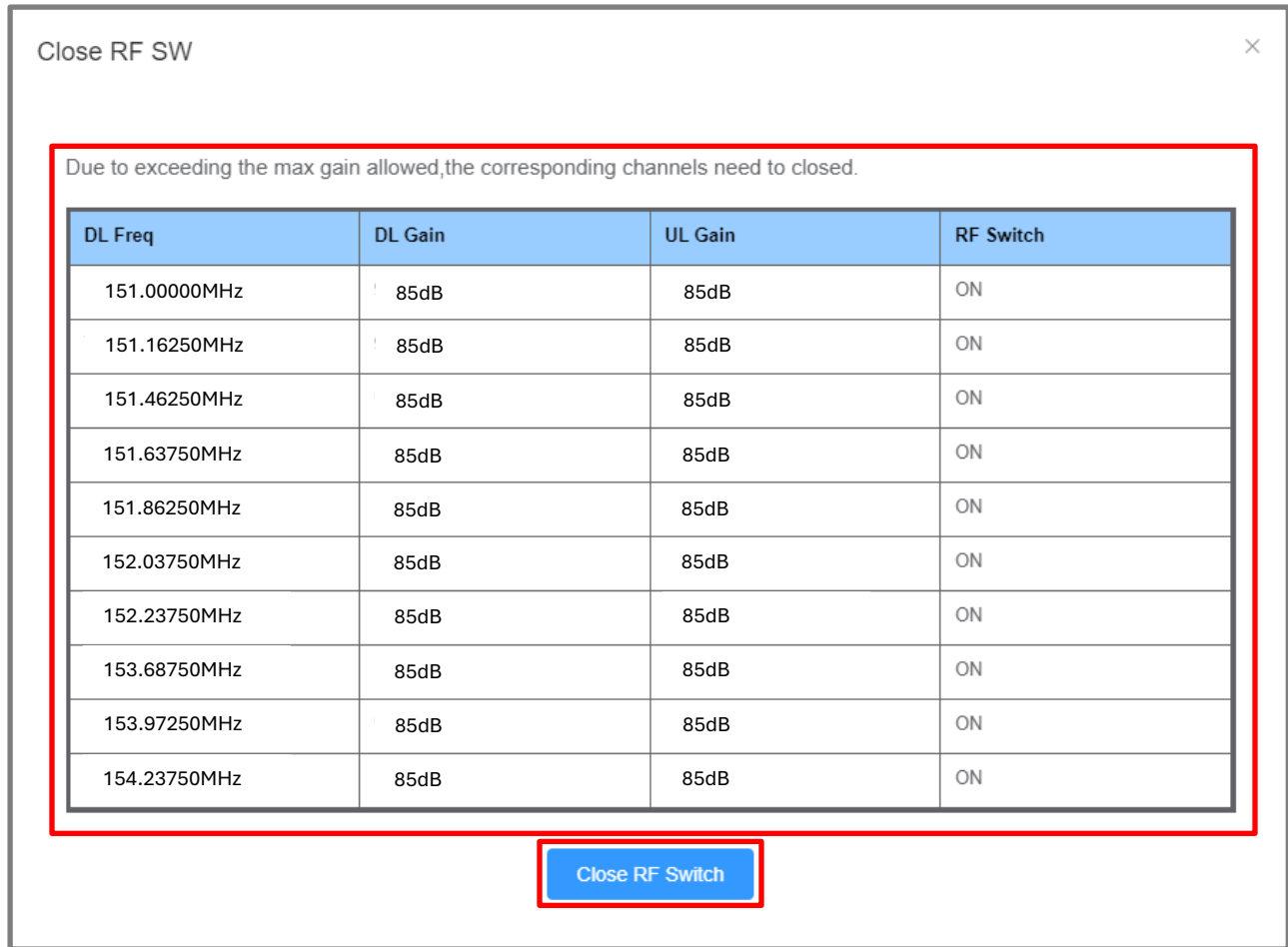

Figure 135: V3 BDA/MU Commissioning Tools – Isolation Check Automatic Filter SW Turn Off Protection

### 3.26 COMMISSIONING TOOL PARAMETER CALCULATIONS (CLASS A BDA)

The V3 BDA has three commissioning tests which the user can estimate RF commissioning parameters. Once the three commissioning tests have been completed, the user can enter some additional system details and generate the suggested values for DL Target Channel Power (DL\_TAR), DL Gain (DL\_GAIN), UL Target Channel Power (UL\_TAR) and UL Gain (UL\_GAIN). The system will calculate the minimum and maximum values based on the user input and commissioning test results. The commissioning tool which generates the suggested RF parameters is located within the <Sites and Channels> view. The user can enter system details into the tool, and it will generate the suggested values for DL\_TAR, DL\_GAIN, UL\_TAR and UL\_GAIN. All three commissioning tests must be completed, and all system details must be entered for the tool to be able to formulate a link budget and generate suggested gain and power values.

The three commissioning tests included are:

- **Isolation Check**

Measures system Isolation and will report any gain to be set over <Isolation> (0). The user can perform an onboard measurement or select manual override to enter a manual measurement. See section 3.25

- **DL Input Test**

Measures the Control Channel Downlink Input Power. The user can perform an onboard measurement or select manual override to enter a manual measurement. See section 3.26

- **UL Input Test**

Measures Uplink Max and Min Input to the BDA. The user can perform an onboard measurement or select manual override to enter a manual measurement. See section 3.26

**Note:** Due to SW limitations, when the V3 system is in a class B configuration or in DAS mode/view, only the <Isolation Check> tool is available.

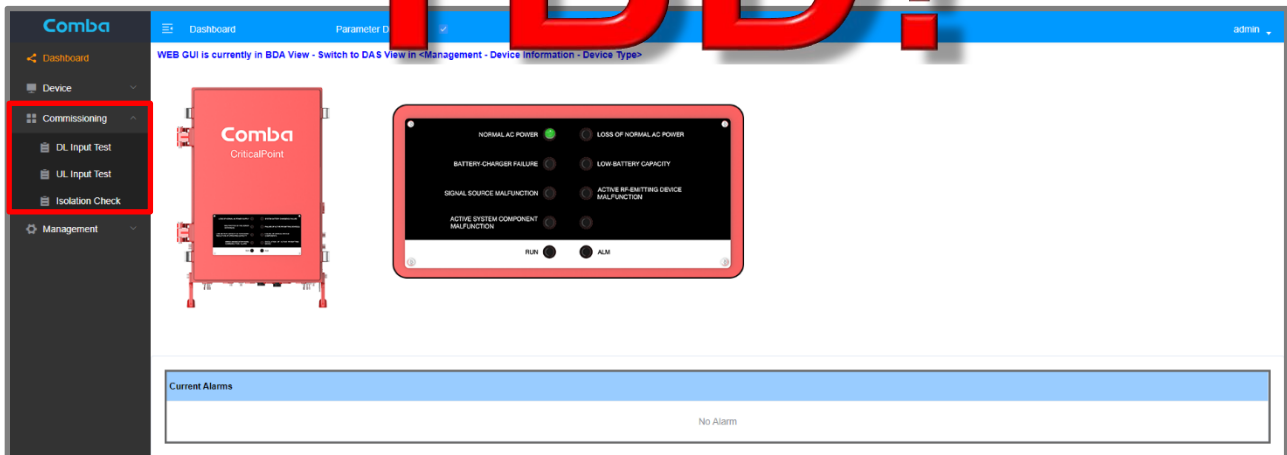

Donor Site Parameters	Site Parameters	Measurements/Final Loss Calculation
Donor Site TX ERP(dBm)	BDA Donor Antenna Gain(dB)	DL Input(dBm)
Donor Site TXRX Delta(dB)	BDA Donor Cable Loss(dB)	UL Input(dBm)
Donor Site RX RSSI(dBm)	D (M) to Donor Site(FSL)(dB)	Isolation 700 and 800MHz (dB)
		Selected Loss(dB)
		DL Total Loss 1 (dB)
		UL Total Loss 2 (dB)
		Donor Site Estimated Noise Floor(dBm/10KHz)
		UL Gain(dB)
		~134dBute ON, ~134dBute OFF)

Figure 136: V3 BDA Class A Commissioning Tools and Calculations

**Commissioning Tool Procedure:**

- In the Commissioning section, perform a DL Input Test, UL Input Test and Isolation Check.
- Navigate to Sites Management page.
- Click on <Set> in Donor Site Parameters section of the Commissioning tool to enter the Donor Site TX ERP (dBm), Donor Site TX/RX Delta Loss (dB) and the Donor Site RSSI (dBm).
- Click on <Set> in Site Parameters section of the Commissioning tool to enter the BDA Donor Antenna Gain (dB), BDA Donor Cable Loss (dB) and the BDA Distance to Donor Site (Mi).
- Review the Measurements/Final Loss Calculation section of the GUI and ensure that the DL Input (dBm), UL Input (dBm), and Isolation VHF and UHF (dB) cells have populated with the values previously obtained by the three commissioning tests. Choose which UL Total Loss to be used. See the following section **Commissioning Tools Calculations Explained** for more details.
- In the <Filter Target Output Power and Gain Suggestion> section, click <Generate>.
- The results will be displayed in the section of the table.

**Note:** See Section 3.2 for an explanation of the required RF Input requirements for commissioning. It is the RF technician's responsibility to decide if the suggested gain and power values should be used. If the technician feels confident all details that have been outlined and entered are correct, and the suggested values that were generated by the BDA page are appropriate, they can move forward with programming these gain and power levels into the GUI. See section 5.28 and 5.29 for setting gain and power levels.

The screenshot illustrates the workflow of the Commissioning Tool. It is divided into three main sections:

- Top Section:** The main 'Site Management' interface. A 'Hide Commissioning Tool' button is visible. The 'Donor Site Parameters' and 'Site Parameters' sections are highlighted with red boxes. A large red 'TBD!' is overlaid on this section.
- Middle Left Section:** A 'Donor Site Parameters' dialog box. It contains fields for:
  - Donor Site TX ERP(dBm): 50
  - Donor Site TX/RX Delta Loss(dB): -15
  - Donor Site RX RSSI Max Required(dBm): -75
  - Donor Site RX RSSI Min Required(dBm): -95
 A 'Set Donor Site Parameters' button is shown.
- Middle Right Section:** A 'Site Parameters' dialog box. It contains fields for:
  - BDA Donor Antenna Gain(dB): 14
  - BDA Donor Cable Loss(dB): 3
  - BDA Distance to Donor(Mi): 2.7
 A 'Set Site Parameters' button is shown.
- Bottom Section:** The 'Filter Target Output Power and Gain Suggestion' section. A 'Generate' button is highlighted with a red box and labeled 'Click Generate'. Below it, a table of results is shown, with a 'Review Results' label pointing to it.
 

DL Target(700MHz)dBm	DL Gain(700MHz)dB	DL Target(800MHz)dBm	DL Gain(800MHz)dB	UL Target(dBm)	UL Gain(dB)	Donor Site Estimated Noise Floor(dBm/10KHz)
23	81	23	81	18	63	<-134(Mute ON), <-134(Mute OFF)

Figure 137: Using the Commissioning Tool

**Commissioning Tool Calculations Explained:**

Figure 138 below shows the relationship between all the parameters that are used in the gain and power calculations.



Figure 138: Commissioning Tool Parameter Calculation Diagram

The RF technician can choose between UL Total Loss 1 or UL Total Loss 2 when generating results in the commissioning tool. It is recommended to use UL Total Loss 2 based on an actual measurement (DL Input Test). The UL Total Loss 2 is based on Free Space Loss and does not include any potential clutter loss. See the following sections for an explanation of UL Total Loss 1 and UL Total Loss 2.

**UL Total Loss 1**

The 3 parameters below are used to calculate UL Total Loss 1.

$$UL\ Total\ Loss\ 1 = Donor\ Site\ TX\ ERP + Donor\ Site\ TX/RX\ Delta - DL\ Input$$

- **Donor Site TX ERP (user fill in):** Donor per Channel Output ERP; acquired from licensee or FCC/ISED web site.
- **Donor Site TX/RX Delta (user fill in):** BTS RX line loss acquired from licensee. A negative value would represent an effective Gain on the BTS RX line (e.g. Tower Top Amplifier).
- **DL Input (auto or manual):** DL Input Power received at the BDA Donor Port. Perform test or manually write a number in the <Commissioning – DL Input Test> section.

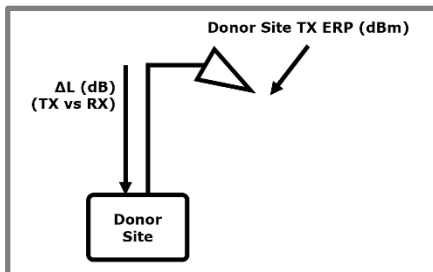

Figure 139: Commissioning Tool – UL Total Loss 1 Parameter Explanation

**UL Total Loss 2**

The 4 parameters below are used to calculate UL Total Loss 2.

UL Total Loss 2 =  $20 \times \log_{10}(\text{Distance}) + \text{BDA Donor Cable Loss} - \text{Donor Site TX/RX Delta (dB)}$

- **BDA Donor Cable Loss (user fill in):** Power loss on signal deployment.
- **BDA Donor Antenna Gain (user fill in):** Gain based on design / deployment.
- **Donor Site TX/RX Delta (user fill in):** User fill in the distance to Donor Site. The system will calculate the FSL (Free Space Loss).
- **Donor Site TX/RX Delta (user fill in):** BTS RX line loss; acquired from licensee. A negative value would represent an effective Gain on the BTS RX line (e.g. Tower Top Amplifier).

The user can then decide which UL Total Loss value to use.

- Click on the <Close> button in the <Measurements/Final Loss Calculation> section to select UL Total Loss 1, UL Total Loss 2, or to enter manual value.

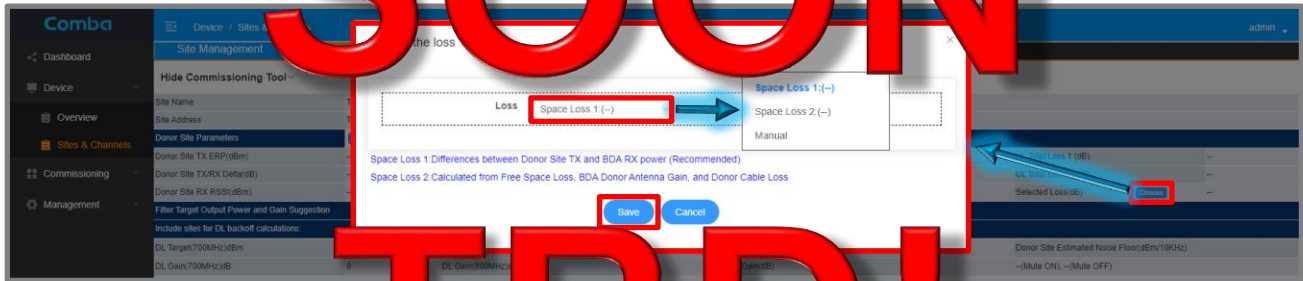

Figure 140: Commissioning - Selecting UL Total Loss Parameter

**Donor Site RX RSSI Range (MAX and MIN Acceptable Signal Received by Donor Site)**

The Max RSSI and Min RSSI need to be entered to calculate the BDA UL Power and UL Gain setting.

If only one number is provided, the user must still estimate the other one.

For example:

If only the MAX RSSI is provided at -95dBm, the MIN RSSI could be -105dBm, or -110dBm, depending on the minimal level that the radio still works. This depends on the requirements from the jurisdiction or licensee, and the sensitivity of the donor site.

If only the MIN RSSI is provided at -95dBm, the MAX RSSI could be -90dBm or -85dBm, depending on the requirements from the jurisdiction or licensee. **The higher the Max RSSI number used, the higher the UL Power and UL Gain will be suggested. Use the lowest MAX RSSI possible to minimize the BDA generated noise levels. The same number can be used for both Max RSSI and Min RSSI in order to minimize UL Power and UL Gain.**

In most cases, using the Max RSSI and Min RSSI requirement provided by the licensee for the BDA output and gain setting calculation, the broadband noise floor generated from the device will be lower than thermal noise before reaching the donor site and cause no impact to Donor Site Sensitivity. However, it is still required to calculate and/or measure the broadband noise for all cases. This calculation is NOT covered in this manual.

**Calculation of DL\_TAR and DL\_GAIN**

DL\_TAR and DL\_GAIN are the key parameters for commissioning the downlink that must be calculated and set up in the BDA.

- **DL\_TAR:** Downlink Target Channel Power; Sets the Max DL Channel Power for a channel filter. The DL Channel AGC circuits will provide the Channel Power from setting this power level.
- **DL\_GAIN:** Downlink Channel Gain; Sets the MAX DL Gain for each channel filter. The device will use the DL Gain for each channel. If Channel Filter's input power is less than the MAX DL Gain is not needed to achieve full DL\_TAR, the DL Channel AGC circuits will automatically reduce the DL Gain accordingly to reach DL\_TAR.

DL\_TAR is calculated using the DL Composite Power and the total channel count per band. The BDA will derate from composite power and evenly share total power across all the channels in a band according to the formula below.

$$DL\_TAR = DL\ Composite\ Power - 10\ Log(\#\ of\ channels)$$

Example:

DL Composite Power = 33dbm

# of Channels = 8

$$DL\_TAR = 33 - 10Log(8) = 33 - 9 = 24dbm$$

Table 19: Commissioning Tool - DL\_TAR Channel Power Derating

# of Channels	BDA DL Composite Output Power	Band Off Factor	Channel Power
1	30dBm	0dB	30dBm
2	30dBm	1.5dB	27dBm
4	30dBm	6dB	24dBm
5	30dBm	7dB	23dBm
8	30dBm	9dB	21dBm
10	30dBm	10dB	20dBm
16	30dBm	12dB	18dBm
20	30dBm	13dB	17dBm
32	30dBm	15dB	15dBm

DL\_GAIN is calculated using the DL Control Channel Input Power and the DL\_TAR. The BDA can measure the DL Input Power using the onboard test, or the user can enter a manual measurement. DL\_GAIN is then calculated using the formula below.

$$DL\_GAIN = DL\_TAR - DL\ IN\ (Control\ Channel\ Input)$$

Example:

DL\_TAR = 20dBm

DL\_IN = -65dBm

$$DL\_GAIN = 20 - (-65) = 85dB$$

**Calculation of UL\_TAR and UL\_GAIN**

UL\_TAR and UL\_GAIN are the key parameters for commissioning the uplink that must be calculated and set up in the BDA.

- **UL\_TAR:** Uplink Target Channel Power. Set the MAX UL Channel Power for each channel filter. The UL Channel AGC circuits will lower the Channel Filter compliance in this power level.
- **UL\_GAIN:** Uplink Channel Gain. Set the MAX UL Gain for each channel filter. The device will use the MAX UL Gain for each channel. If a Channel UL output power is such that the MAX UL Gain is not needed to achieve full UL\_TAR, the UL Channel AGC circuits will automatically reduce the UL Gain accordingly to reach UL\_TAR.

UL\_TAR is calculated using the Donor Site MAX RX RSSI and the UL Total Loss. **The user must choose to use either UL Total Loss 1 or UL Total Loss 2** as previously described in this commissioning tool procedure. The UL\_TAR is the MAX UL Channel Power that it will be received at the donor site no higher than the Donor Site MAX RX RSSI. UL\_TAR is calculated using the formula below.

$$\text{UL\_TAR} = \text{Donor Site MAX RX RSSI (dBm)} + \text{UL Total Loss 1 (dB)}$$

Example 1(Using UL Total Loss 1):  
Donor Site MAX RX RSSI = -75dBm  
UL Total Loss 1 = 85dB

$$\text{UL\_TAR} = -75\text{dBm} + 85\text{dB} = 10\text{dBm/Channel}$$

Example 2(Using UL Total Loss 2):  
Donor Site MAX RX RSSI = -75dBm  
UL Total Loss 2 = 75dB

$$\text{UL\_TAR} = -75\text{dBm} + 75\text{dB} = 0\text{dBm/Channel}$$

**Note: Because UL Total Loss 2 does not include any additional clutter loss, and is based only on free space loss, using it may cause lower than expected levels to be received at the Donor Site!**

UL\_GAIN is calculated using Donor Site MIN RX RSSI, UL Total Loss, and UL MIN Input. The UL Input test must be completed before the UL\_GAIN suggestion can be generated. The UL\_GAIN sets the MAX UL Gain to reach the donor site at the Donor Site MIN RX RSSI level. In other words, UL\_GAIN is minimized as much as possible so the "Far" radio can reach the Donor Site at the lowest level. UL\_GAIN is calculated using the formula below.

$$\text{UL\_GAIN} = \text{Donor Site MIN RX RSSI (dBm)} + \text{UL Total Loss} - \text{UL MIN Input}$$

Example 1:  
Donor Site MIN RX RSSI = -95dBm  
UL Total Loss 1 = 85dB  
UL MIN Input = -65dBm

$$\text{UL\_GAIN} = -95\text{dBm} + 85\text{dB} - (-65\text{dBm}) = 55\text{dB}$$

Example 2:  
Donor Site MIN RX RSSI = -95dBm  
UL Total Loss 1 = 95dB  
UL MIN Input = -75dBm

$$\text{UL\_GAIN} = -95\text{dBm} + 95\text{dB} - (-75\text{dBm}) = 75\text{dB}$$

See Figure 141 below for an example of the UL\_TAR and UL\_GAIN calculation process.



<p>Donor Site MAX RX RSSI = -75dBm                  UL Total Loss = 85dB                  UL_TAR = -75dBm + 85dB</p>	<p>Donor Site MIN RX RSSI = -95dBm                  UL Total Loss 1 = 85dB                  UL MIN Input = -65dBm                  UL_GAIN = -65dBm + 85dB - (-65dBm) = 55dB</p>
--	--

Figure 141: Commissioning Tools – UL\_TAR and UL\_GAIN Calculation Example

**Site DL Backoff Calculations:**

If there are multiple sites being used with channels in the same frequency band, the user can select all sites to be included in the DL Channel Power Back Off calculations. The BDA will count total filters from all sites for DL channel power backoff. If only using one site, just ensure the site you have configured is selected.

- In the <Include sites for DL backoff calculations> section of the commissioning tool, select the site(s) that will be included in the channel count for DL Channel Power Backoff.

Donor Site Parameters		Site Parameters		Measurements/Final Loss Calculation			
Donor Site TX ERP(dBm)	50.00	BDA Donor Antenna Loss(dB)	14.00	DL Input(dBm)	-58.31	UL Total Loss 1 (dB)	93.31
Donor Site TX/RX Delta(dB)	-15.00	BDA Donor Cable Loss(dB)	3.00	UL Input(dBm)	-65 - -40	UL Total Loss 2 (dB)	77.34
Donor Site RX RSSI(dBm)	-95.00 ~ -75.00	D.(M) to Donor Site Loss(dB)	2.70/103.34	Isolation 700 and 800MHz (dB)	100/100	Selected Loss(dB)	93.31

Filter Target Output Power and Gain Suggestion						
Include sites for DL backoff calculations: 700/800MHz Site 1: <input checked="" type="checkbox"/> All: <input checked="" type="checkbox"/>						
DL Target(700MHz)dBm	23	DL Target(800MHz)dBm	23	UL Target(dBm)	18	Donor Site Estimated Noise Floor(dBm/10KHz)
DL Gain(700MHz)dB	81	DL Gain(800MHz)dB	81	UL Gain(dB)	63	<-134(Mute ON), <-134(Mute OFF)

Figure 142: Commissioning Tool – Selecting Sites for DL Channel Power Backoff Calculations

**Commissioning Tool Results:**

- To generate the suggested values for DL\_GAIN, DL\_TAR, UL\_GAIN, and UL\_TAR, you must click on the <Generate> button of the Commissioning Tool window.

COMING SOON

**View the results in the lower window of the commissioning tool. The suggested values are for reference only. The result will NOT apply to any filters. Users need to manually apply the values if they are satisfied with the procedure results. Results should be compared to System Design and inconsistencies should be reviewed before commissioning and turning on the RF Switches.**

TBD!

DL Target(700MHz)dBm	23	DL Target(800MHz)dBm	23	UL Target(dBm)	18	Donor Site Estimated Noise Floor(dBm/10KHz)
DL Gain(700MHz)dB	81	DL Gain(800MHz)dB	81	UL Gain(dB)	63	<-134(Mute ON), <-134(Mute OFF)

Figure 143: Commissioning Tool – Viewing the Suggested RF Parameters

### 3.27 POWER, GAIN, ATTENUATION, AND AGC/ALC CONTROLS

**BDA Diagram and RF Parameters**

The V3 BDA has multiple parameters to control the gain and power and provides AGC/ALC to limit the output power. See Figure 144 and Table 19 for a detailed description of these parameters.

**Note:** The diagram below is NOT depicting the actual block diagram of the system but is a simplified diagram showing the approximate function of each parameter.

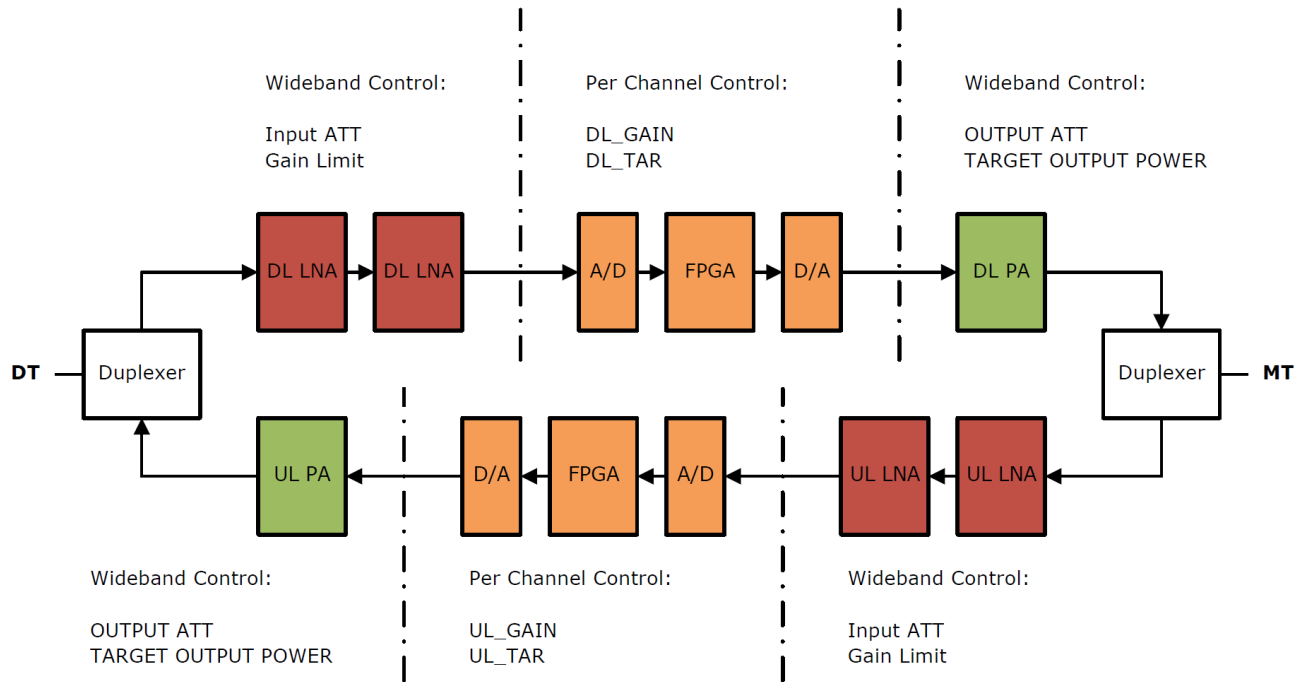

Figure 144: Commissioning BDA – Power, Gain, and Attenuation BDA Block Diagram

Table 19: Commissioning BDA – Power, Gain, Attenuation and AGC/ALC Controls

Parameter Name	Function	When to use
<b>Input ATT</b> ( <a href="#">Overview / Sites &amp; Channels page</a> )	0–30dB range to reduce from Total Gain* and reduce BDA Input Power. This affects wideband gain.	When Input Power is high
<b>Gain Limit</b> ( <a href="#">Advanced / Sites &amp; Channels page</a> )	Option to set Total Gain* to 60dB or 85dB. When 60dB is selected, the BDA will bypass an input LNA.	When Input Power is high and System requires 60dB gain or less.
<b>DL_GAIN / UL_GAIN</b> ( <a href="#">Site &amp; Channels page</a> )	Channel Gain Setting. 0-30dB range below Total Gain. This is to control gain for individual filters.	Use to set the gain for individual filters.
<b>Output ATT</b> ( <a href="#">Overview / Sites &amp; Channels page</a> )	0-20dB range to reduce the Total Gain* and reduce Target Channel Output Power at the same time. This affects wideband	When Output Power is high When lower Output Broadband Noise is desired (Near Donor Site).
<b>DL_TAR / UL_TAR</b> ( <a href="#">Site &amp; Channels page</a> )	Sets the output power limit for individual filters.	Set to the target filter output power.
<b>Target Composite Output Power</b> ( <a href="#">Overview page</a> )	Limit the device's composite output power.	<b>Not recommended to use.</b> If the user wants to reduce the composite output power, use Output ATT or DL_TAR / UL_TAR for better RF performance.

\***Total Gain:** the max gain that the system is configured to use. It is affected by the Input ATT, Gain Limit and/or Output ATT.

Example:

The calculated DL Gain that is required is 50dB. The BDA DL\_Gain only has a 30dB adjustment range and the default MAX Gain setting is 85dB (Total Gain of 85dB). The user can only reduce the DL CH\_Gain from 85dB to 55dB. Rather than using external attenuators to reduce the gain to 50dB, the user can adjust either DL Input ATT, DL Output ATT, or DL Gain Limit (Bypass LNA) to reduce the Total Gain to 80dB or lower, then use DL CH\_Gain to adjust it to 50dB.

### **BDA Gain, Power, and AGC/ALC**

Once a Target Channel Output Power and CH\_Gain have been set, the AGC/ALC level will be set for the channel filter. If input power is below a level in which the CH\_Gain will amplify it to Target Channel Output Power, gain will not be reduced by AGC/ALC. If the input power is above a level in which the CH\_Gain will amplify it above Target Channel Output Power, the AGC/ALC circuits will automatically reduce the gain to reach the Target Channel Output Power.

- DL\_IN: always indicates the **channel power read from DT port**, regardless of what the Gain Limit or ATT settings in the system.
- DL\_GAIN: the gain that will be applied to the input.
- The expected DL\_OUT can be calculated as: **DL\_OUT = DL\_IN + DL\_GAIN**  
And **if DL\_OUT > DL\_TAR**, system will limit **DL\_OUT = DL\_TAR**.

The Gain Limit / ATT / Target Output Power will affect the max value for gain and/or DL\_TAR that users can set. See Figure 145 below which shows the <Sites & Channels> page and the RF parameters.

#	DLFreq	DL Filter	DL SW	DL_IN	DL_OUT	DL_TAR	DL_GAIN	DL_AGC	ULFreq	UL Filter	UL SW	UL_IN	UL_OUT	UL_TAR	UL_GAIN	UL_AGC	Descr
No Data																	
UHF+	DL RF atten	off		UL RF atten	off		DL Gain Limit	none	UL Gain Limit	none		DL Input AGC	0				
	DL Input ATT	6dB		UL Input ATT	6dB		DL Output ATT	6dB	UL Output ATT	6dB		DL Output AGC	0				

#	DLFreq	DL Filter	DL SW	DL_IN	DL_OUT	DL_TAR	DL_GAIN	DL_AGC	ULFreq	UL Filter	UL SW	UL_IN	UL_OUT	UL_TAR	UL_GAIN	UL_AGC	Descr
1	452.36250MHz	75KHz	ON	<-110.00dBm	<-7.00dBm	14dBm	70dB	0	457.36250MHz	75KHz	ON	<-110.00dBm	<-7.00dBm	10dBm	65dB	0	...
2	452.76250MHz	75KHz	ON	<-110.00dBm	<-7.00dBm	14dBm	70dB	0	457.76250MHz	75KHz	ON	<-110.00dBm	<-7.00dBm	10dBm	65dB	0	...
3	453.28750MHz	75KHz	ON	<-110.00dBm	<-7.00dBm	14dBm	70dB	0	458.28750MHz	75KHz	ON	<-110.00dBm	<-7.00dBm	10dBm	65dB	0	...
4	461.16250MHz	75KHz	ON	<-110.00dBm	<-7.00dBm	14dBm	70dB	0	466.16250MHz	75KHz	ON	<-110.00dBm	<-7.00dBm	10dBm	65dB	0	...

Figure 145: Commissioning BDA – Power, Gain, and AGC/ALC

**Fiber DAS Diagram and RF Parameters**

The V3 Fiber DAS has multiple parameters to control the gain and power and provides AGC/ALC to limit the output power. The Fiber DAS system structure and RF parameters are built based on the BDA. Refer to the content from the previous section. See Figure 146 and Table 20 for a detailed description of the Fiber DAS parameters.

**Note:** The diagram below is NOT depicting the actual block diagram of the system but is a simplified diagram showing the approximate function of each parameter.

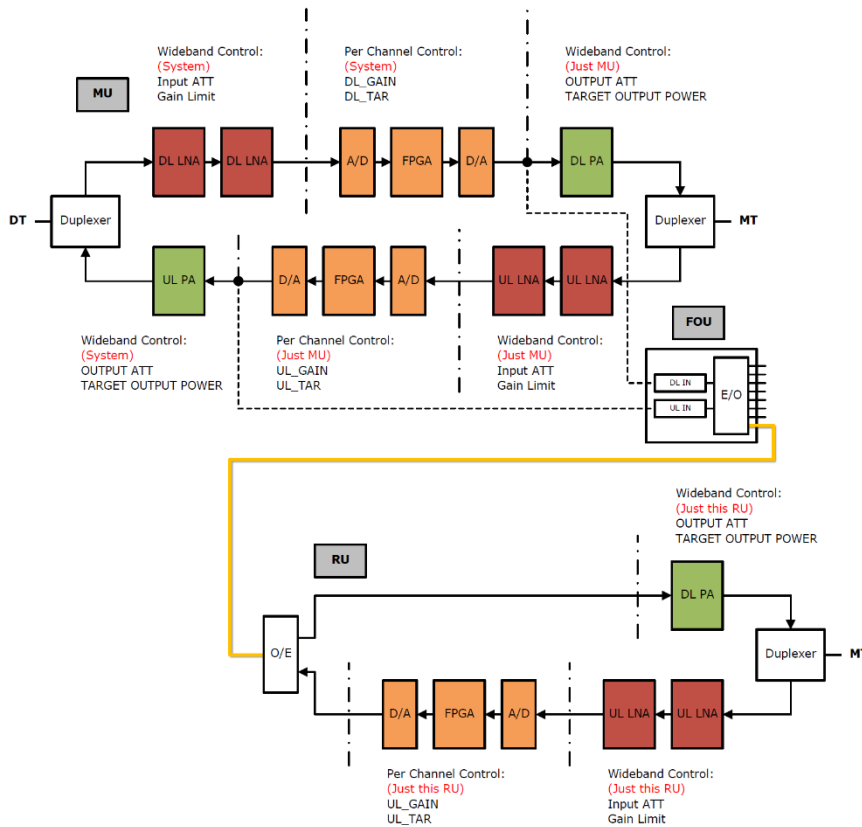

Figure 146: Commissioning Fiber DAS – Power, Gain, and Attenuation BDA Block Diagram

Table 20: Commissioning Fiber DAS – Power, Gain, Attenuation and AGC/ALC Controls

Parameter Name	MU	RU
DL Input ATT	Controls DL Input Attenuation for System	N/A
DL Gain Limit	Controls DL Gain Limit for System	N/A
DL_GAIN	Controls DL Gain for System	N/A
DL Output ATT	Controls DL Output ATT for MU only	Controls DL Output ATT for RU only
DL_TAR	CH TAR = MU DL_TAR - <b>MU Output ATT</b>	CH TAR = MU DL_TAR - <b>RU Output ATT</b>
DL Target Composite Output Power	Controls DL Target Composite Output Power for MU only	Controls DL Target Composite Output Power for RU only
UL Input ATT	Controls UL Input ATT for MU only	Controls UL Input ATT for RU only
UL Gain Limit	Controls UL Gain Limit for MU only	Controls UL Gain Limit for RU only
UL_GAIN	Controls UL Gain for MU only	Controls UL Gain for RU only
UL Output ATT	Controls UL Output ATT for BDA/MU	N/A
UL_TAR	Controls UL_Tar for MU only	Controls UL_Tar for RU only
UL Target Composite Output Power	Controls UL Target Composite Power for System	N/A

The DL Output ATT is used to set different output power on different devices.

Example:

DL\_TAR at MU = 20dBm per filter

DL Output ATT at MU = 0dB

DL Output ATT at RU01 = 5dB,

Channel Output at MU= 20dBm

Channel Output at RU= 15dBm

The **UL\_TAR / UL\_GAIN** can be set differently at each device. However, they should be the same in most cases. Use Batch Setting to set all devices parameters to the same UL\_TAR / UL\_GAIN. See section 3.28 for Batch Setting device parameters.

**UL Output ATT** in MU can be used to reduce the total output power and/or the broadband UL noise floor which is generated by the UL Power Amplifier of the BDA/MU.

### **Fiber DAS Power, Gain, Attenuation, and AGC/ALC**

The Fiber DAS follows the same rules as described in the BDA section above.

- DL\_IN at MU: always indicates the **channel power read from DT port**, regardless of what the Gain Limit or ATT settings in the system.
- DL\_GAIN at MU: the gain that will be applied to the input.
- The expected DL\_OUT at MU/RU can be calculated as: **DL\_OUT = DL\_IN + DL\_GAIN**  
And if **DL\_OUT > DL\_TAR**, system will limit **DL\_OUT = DL\_TAR**.

The Gain Limit / ATT / Target Output Power will affect the max value for gain and/or DL\_TAR that users can set.

### 3.28 COMMISSIONING – SETTING POWER, GAIN, AND ATTENUATION

Once the main RF parameters that need to be configured are known, the user can program the BDA/DAS accordingly. Setting Power, Gain, and Attenuation settings are different in BDA mode vs. DAS mode. See the following sections which describe the process to set these parameters in both BDA configuration and in a Fiber DAS configuration.

#### Setting Power, Gain, and Attenuation in BDA mode

The RF parameters can be programmed in different manners if in BDA mode. The reason is to provide flexibility with channel settings.

#### Setting RF Parameters for Individual Channel Filters

The user can click <Modify> in a Channel Filter row to update the Power and Gain settings for that channel only.

- Navigate to <Device – Sites & Channels>.
- Click on <Modify> in a channel filter row to update the Power and Gain for that channel only

#### Batch Setting RF Parameters to all Channel Filters

The user can select <Batch Setting> and set the same Power and Gain for every channel or a specific range of channels. In most cases this is the preferred method to reduce time.

- Navigate to <Device – Sites & Channels>.
- Click <Batch Setting> for a band to update the Power and Gain for all channels in the band. If using <Batch Setting>, the user can set the DL Filter BW, UL Filter BW, DL\_TAR, UL\_TAR, DL\_GAIN, UL\_GAIN, and turn ON the Channel RF Switches for all channel filters in the band. **Start Channel No / End Channel No** – the range of filters to be set in the Batch Setting
- Enter the RF parameters you would like to program and ensure the checkbox is checked for that parameter then click <Save>.

See Figure 147 below for more details.

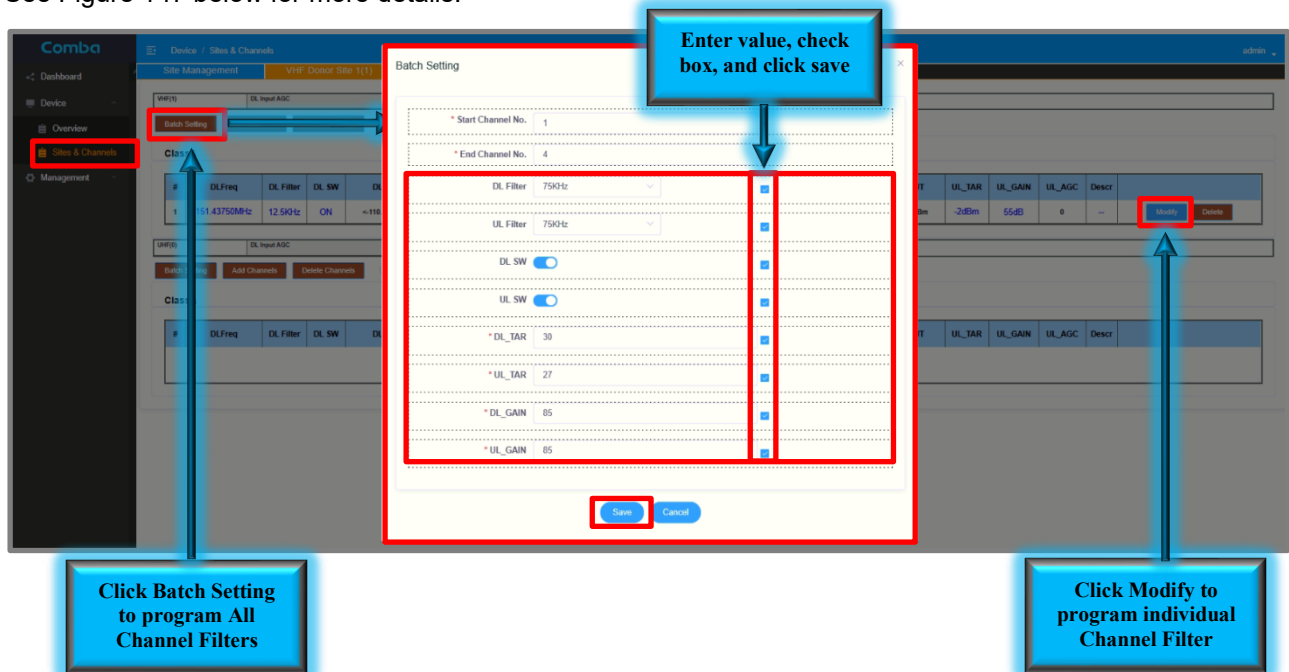

Figure 147: Commissioning BDA – Setting Target Channel Power and Gain

**Setting Input ATT, Output ATT, Gain Limit, and Main RF Switches**

The Input ATT, Output ATT, Gain Limit, and RF Switches can be configured from the <Device – Sites & Channels> page. Input ATT and Output ATT can also be configured in the <Device – Overview – BDA Overview> page. Gain Limit can also be configured in the <Device – Overview – BDA Overview> page. The parameters are available in several places for convenience. However, the easiest way to configure these parameters are from the <Device – Sites & Channels> page as they can all be modified quickly from the same window while monitoring RF levels in the channel filter sections.

To modify these RF parameters:

- Navigate to <Device – Sites & Channels>. There is narrow window above each channel filter section where these parameters can be controlled. The user can set the DL Input ATT, UL Input ATT, DL Output ATT, UL Output ATT, DL Gain Limit, UL Gain Limit, and Turn ON/OFF the Main DL/UL RF Switches.
- Click on the parameter text for a parameter to modify it. Click <Save>.

See Figure 148 for more details.

The screenshot shows the 'Device / Sites & Channels' interface. At the top, there are tabs for 'Site Management' and 'VHF Donor Site 1(1)'. Below this, there are buttons for 'Batch Setting', 'Add Channels', and 'Delete Channels', along with radio buttons for 'DL Only', 'UL Only', and 'All'. A table titled 'ClassA' lists various parameters including DL Freq, DL Filter, DL SW, DL\_IN, DL\_OUT, DL\_TAR, DL\_GAIN, DL\_AGC, UL Freq, UL Filter, UL SW, UL\_IN, UL\_OUT, UL\_TAR, UL\_GAIN, UL\_AGC, and Descr. A red box highlights a summary row for DL/UL parameters. A callout box points to this row with the text 'Change Input ATT, Output ATT, and Gain Limit in the Top Window'. Below this, a detailed parameter table shows DL RF Switch, DL Input ATT, UL RF Switch, UL Input ATT, DL Gain Limit, DL Output ATT, UL Gain Limit, and UL Output ATT. A callout box points to the 'DL Input ATT' parameter with the text 'Click on the parameter text to change a setting'. This leads to a modal dialog box for 'DL Input ATT(dB)' with a value of 0 and 'Save' and 'Cancel' buttons.

Figure 148: Commissioning BDA – Setting Input ATT, Output ATT, Gain Limit and Main RF Switches

### **Setting Power, Gain, and Attenuation in DAS mode**

The RF parameters can be programmed in different manners if in DAS mode. The reason is to provide flexibility with channel settings.

#### **Setting RF Parameters for Individual Channel Filters**

The user can click <Modify> in a Channel Filter row to update the Power and Gain settings for that channel only.

For MU, the process is the same as for the BDA (See Figure 147):

- Navigate to <Device – Sites & Channels>.
- Click on <Modify> in a channel filter row to update the Power and Gain for that channel only

For individual RU, the UL Power and UL Gain can be changed by accessing the RU:

- Navigate to the RU at <Dashboard – Table View – Click on RU – Device – Sites & Channels> or from <Home – RU Checkbox – Channels & Sites>
- Click on <Modify> in a channel filter row to update the Power and Gain for that channel only

#### **Batch Setting RF Parameters to all Channel Filters for the System**

The user can select <Batch Setting> and set the same Power and Gain for every channel or a specific range of channels. In most cases this is the preferred method to reduce time.

For MU, the process is the same as for the BDA (See Figure 147):

- Navigate to <Device – Sites & Channels>.
- Click <Batch Setting> for a band to update the Power and Gain for all channels in the band. If using <Batch Setting>, the user can set the Filter BW, DL\_TAR, UL\_TAR, DL\_GAIN, UL\_GAIN, turn ON the Channel RF Switches for all channel filters in the band.  
**Start Channel No / End Channel No** – the range of filters to be set in the Batch Setting
- Enter the RF parameters you would like to program and ensure the checkbox is checked for that parameter then click <Save>.

For RU, the UL Power and Gain can be set for all RUs in the System:

- Navigate to <Device – Batch Setting>.
- Click the checkboxes for the RU devices you wish to configure the UL Power and UL Gain settings on. If you want to configure all RUs, you can select <Select All Devices>.
- If using <Device - Batch Setting>, the user can set the UL\_TAR, UL\_GAIN, RU Output ATT, UL Mute Switch, UL Mute Threshold, UL Gain Limit, and turn ON the System RF Switches for all channel filters in the band for all RUs.  
**Start Channel No / End Channel No** – the range of filters to be set in the Batch Setting
- Enter the RF parameters you would like to program and ensure the checkbox is checked for that parameter then click <Save>.

See Figure 149 below for more details.

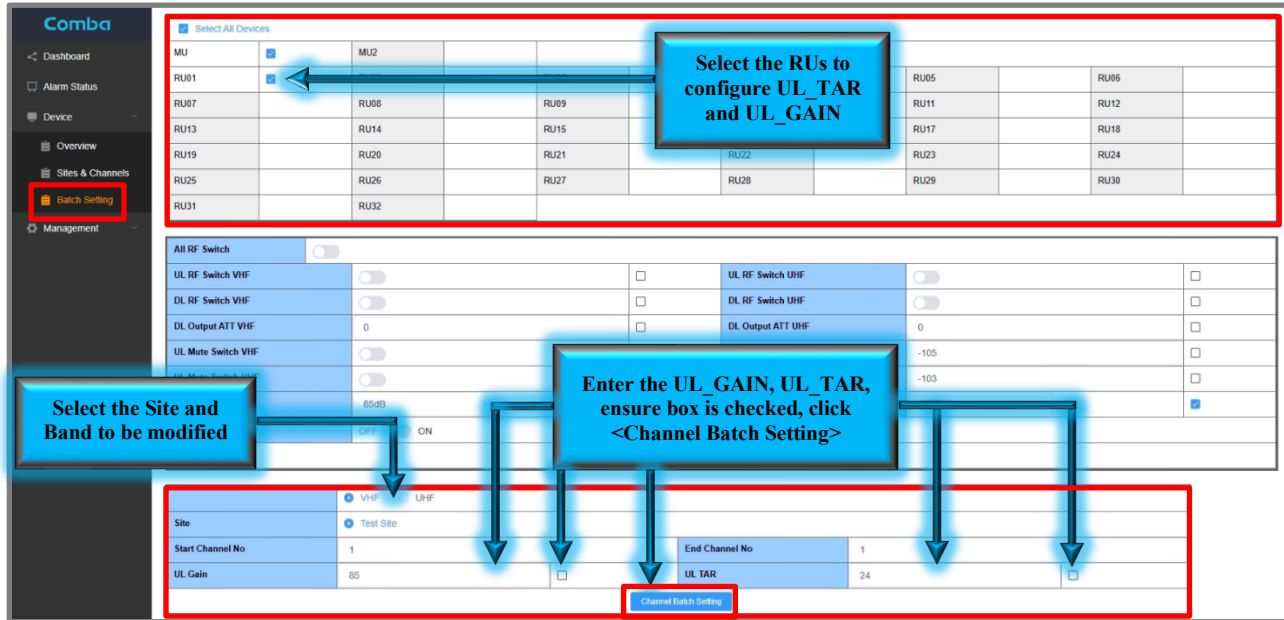

Figure 149: Commissioning Fiber DAS – Batch Setting Power and Gain Settings to RUs

### Setting Input ATT, Output ATT, and Gain Limit

The Input ATT, Output ATT, Gain Limit, and RF Switches for MUs and RUs can be configured in different manners. The parameters are available in several places for convenience. However, the easiest way to configure these parameters for the MU are from the <Device – Sites & Channels> page as they can all be modified quickly from the same window while monitoring RF levels in the channel filter sections. The easiest way to configure these parameters for the RUs is by using the <Device – Batch Setting> page to configure all RU parameters all at once.

For MU, the process is the same as the BDA (See Figure 148):

- Navigate to <Device – Sites & Channels>. There is narrow window above each channel filter section where these parameters can be controlled.
- Click on the parameter text for a parameter to modify it. Click <Save>.

For individual RU, the basic process is the same as the BDA and MU (See Figure 148):

- Navigate to Access the RU you want to modify.  
Navigate to <Dashboard – Table View – Click on RU – Device Sites and Channels>  
Alternatively, Navigate to <Home – RU Checkbox – Channels & Sites>
- Click on the parameter text for a parameter to modify it. Click <Save>.

For Batch Setting RUs:

- Navigate to <Device – Batch Settings>. RU DL Output ATT, and RU UL Gain Limit can be configured in the middle window.
- Select the RU checkboxes that need to be modified
- Enter the desired DL Output ATT and UL Gain Limit, ensure checkboxes are checked next to parameter, and then click <Batch Setting>

See Figure 150 for more details.

The screenshot displays the Comba web interface for configuring Fiber DAS. The interface is divided into several sections:

- RU Selection Table:** A table with columns for MU and RU IDs (RU01 to RU32). The 'Select All Devices' checkbox is checked, and checkboxes for MU1 and RU01 are also checked.
- Settings Table:** A table with columns for VHF and UHF settings. The 'UL Gain Limit UHF' setting is set to 85dB and has a checked checkbox.
- Batch Setting Button:** A red button labeled 'Batch Setting' is located at the bottom right of the settings table.

Callout boxes with arrows provide the following instructions:

- Select the RUs to configure Output ATT and UL Gain Limit:** Points to the checked checkboxes in the RU selection table.
- Set the DL Output ATT per Band:** Points to the 'DL Output ATT VHF' and 'DL Output ATT UHF' settings in the settings table.
- Set the UL Gain Limit per Band:** Points to the 'UL Gain Limit VHF' and 'UL Gain Limit UHF' settings in the settings table.
- Click Batch Setting to apply to RUs:** Points to the 'Batch Setting' button.

Figure 150: Commissioning Fiber DAS – Batch Setting RU Output ATT and UL Gain Limit

### 3.29 COMMISSIONING – PARAMETER OPTIMIZATION

**Optimizing Downlink in BDA Mode:**

**Downlink Channel Input (DL\_IN), Target Power (DL\_TAR), Downlink Gain (DL\_GAIN) should be already calculated. Ensure Main RF Switches and Channel RF Switches are turned ON.**

For DL Input:

- **Monitor <DL Input AGC>; Front-End Gain can be reduced by doing any of the following**
  - a. Use DL Gain Limit, if total DL gain required can be 60dB or lower.
  - b. Use DL Input ATT, to reduce the DL Input AGC to be below 10dB, if total gain required is >60dB.

It is recommended to use only DL Input ATT or DL Gain Limit, but not both.

The purpose of mitigating DL Input AGC is to ensure you do not saturate the front-end receiver of the BDA and keep the LNA in its linear range.

The current gain setting will change after modifying the Gain Limit or DL Input ATT, and the user must reset the desired gain.

Example:

1. The original Filter's DL Gain was set to 80dB for each filter.
2. DL Input AGC = 15dB; User decides to set 10dB of DL Input ATT.
3. Filter DL Gain is reduced to 70dB for each filter.
4. The user must Batch set Filter's DL Gain back to 80dB.

In this example, essentially, 10dB attenuation is relocated from later stage (in FPGA) to the front end.

#	DL Freq	UL Freq	Filter	DL_IN	DL_OUT	DL_TAR	UL_TAR	UL_IN	UL_OUT	DL_GAIN	UL_GAIN	DL_AGC	UL_AGC	DL Input AGC	UL Output AGC
1	769.500000MHz	799.500000MHz	25KHz	<-110.00dBm	<-7.00dBm	23dBm	18dBm	<-110.00dBm	<-110.00dBm	80dB	63dB	0	0	15dB	0
2	770.000000MHz	800.000000MHz	25KHz	<-110.00dBm	<-7.00dBm	23dBm	18dBm	<-110.00dBm	<-110.00dBm	80dB	63dB	0	0	15dB	0
3	770.500000MHz	800.500000MHz	25KHz	<-110.00dBm	<-7.00dBm	23dBm	18dBm	<-110.00dBm	<-110.00dBm	80dB	63dB	0	0	15dB	0
4	771.000000MHz	801.000000MHz	25KHz	<-110.00dBm	<-7.00dBm	23dBm	18dBm	<-110.00dBm	<-110.00dBm	80dB	63dB	0	0	15dB	0
5	771.500000MHz	801.500000MHz	25KHz	<-110.00dBm	<-7.00dBm	23dBm	18dBm	<-110.00dBm	<-110.00dBm	80dB	63dB	0	0	15dB	0
6	772.500000MHz	802.500000MHz	25KHz	<-110.00dBm	<-7.00dBm	23dBm	18dBm	<-110.00dBm	<-110.00dBm	80dB	63dB	0	0	15dB	0
7	DL RF Switch		OFF	UL RF Switch		OFF		DL Gain Limit		90dB					
8	DL Input ATT		0dB	UL Input ATT		0dB		DL Output ATT		0dB					
9	774.000000MHz	804.000000MHz	25KHz	ON	<-110.00dBm	<-7.00dBm	23dBm	18dBm	<-110.00dBm	<-7.00dBm	80dB	63dB	0	0	--
10	774.500000MHz	804.500000MHz	25KHz	ON	<-110.00dBm	<-7.00dBm	23dBm	18dBm	<-110.00dBm	<-7.00dBm	80dB	63dB	0	0	--

Figure 151: Optimizing BDA – DL Input ATT and DL Gain Limit

**For DL Output:** If the original DL Target Power (DL\_TAR) and DL Gain (DL\_GAIN) settings do not meet the coverage requirements, the following optimization steps can be used.

**If DL RSSI is too Low:**

Adjust to higher DL\_TAR and DL\_GAIN. This will reduce the headroom of power reserved when presuming all channels will burst at same time. **Refer to local codes if this adjustment is allowed.**

**If less power is desired, there are 3 options:**

- Set lower Target Power (DL\_TAR) and gain (DL\_GAIN). (note in DAS deployment: it will affect all RU's output)
- Use DL Output ATT to attenuate the DL Output.

It will reduce the maximum BDA DL output and/or broadband noise output.

The broadband noise will drop linearly with output power in the first 10dB of attenuation. And non-linear (after 10dB of attenuation. (Noise is normally not a concern for DL)

DL\_TAR range and DL\_GAIN range will also be reduced after using DL Output ATT. However, in this case, users most likely do not need to change the DL\_TAR or DL\_GAIN again. The DL\_TAR shown in the WEB will be the max output power per channel measured at MT Port.

- Apply a physical external attenuator.

Note: If an attenuator is installed on the MT port, it will reduce the UL Max Input / UL Min Input. (Uplink is intended to be attenuated in many cases)

### **Optimizing Uplink in BDA Mode**

**Uplink Max & Min Input, Target Power (UL\_TAR), Gain (UL\_GAIN) should be already calculated. Ensure Main RF Switches and Channel RF Switches are turned ON.**

**For UL Input:**

- If MAX\_UL\_IN is more than -30dBm:
  - a. Use UL Gain Limit, if Total UL Gain required can be 60dB or lower.
  - b. Use UL Input ATT, to reduce the MAX\_UL\_IN to be <-30dBm, if total gain required is >60dB.

It is recommended to use only UL Input ATT or UL Gain Limit, but not both.

**Example:**

1. The original Filter's UL Gain was set to 70dB for each filter.
2. MAX\_UL\_IN = -20dBm, decide to set 10dB of UL Input ATT.
3. Filter UL Gain is reduced to 60dB for each filter.
4. Batch set Filter's UL Gain back to 70dB.

In this example, essentially, 10dB attenuation is relocated from later stage (in FPGA) to the front end.

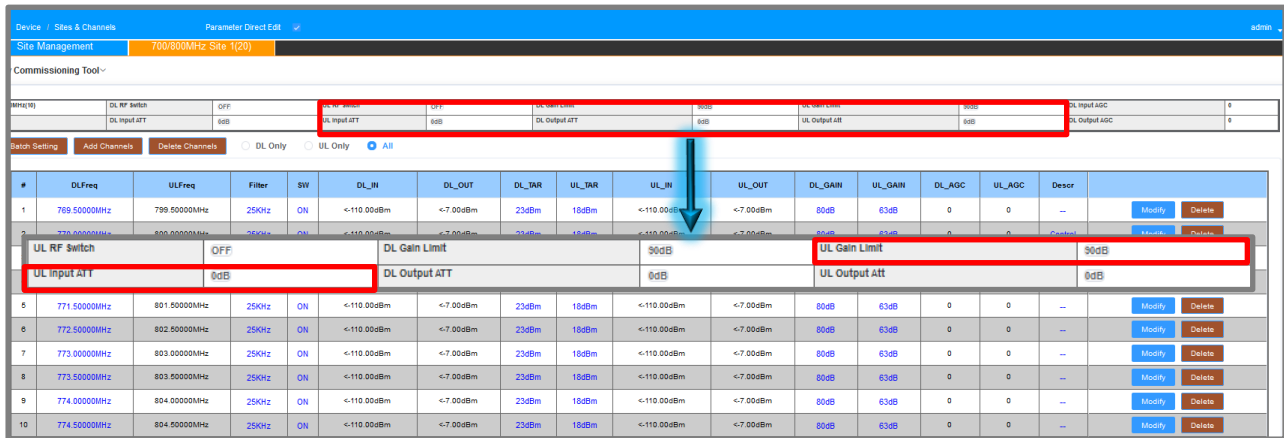

Figure 152: Optimizing BDA – UL Input ATT and UL Gain Limit

**For UL Output:** If the original UL Target Power (UL\_TAR) and UL Gain (UL\_GAIN) settings do not meet the coverage requirement:

**If UL RSSI at Donor Site is too Low:**

Confirm power calculation, Donor Site RSSI requirement, and the total loss first. (In many cases a failed Uplink test is NOT because of lack of UL Power!). If more UL Power is determined to be required, adjust to a higher UL\_TAR and UL\_GAIN. This will reduce the headroom of power reserved when presuming all channels will burst at same time. However, in the Uplink path, it is not expected to have many simultaneous UL transmissions from radios compared to the Downlink path. In other words, less headroom is required in the Uplink.

If less power or less broadband noise is desired, there are 3 options:

- Set a lower UL Target Power (UL\_TAR) and UL Gain (UL\_GAIN).
- Use UL Output ATT to attenuate the UL Output.

It will reduce the maximum BDA UL output and broadband noise output.

The broadband noise will drop linearly with output power in the first 10dB of attenuation. And non-linear (after 10dB of attenuation. (Noise is normally not a concern for DL)

UL\_TAR range and UL\_GAIN range will also be reduced after using UL Output ATT. However, in this case, users most likely do not need to change the UL\_TAR or UL\_GAIN again. The UL\_TAR shown in the WEB will be the max output power per channel measured at DT Port.

- Apply a physical external attenuator. (It can reduce both the power and noise floor in an easy way.)

Note: if an attenuator is on DT port, it will also reduce the DL Input. (Downlink is intended to be attenuated in many cases)

**UL Mute**

It is highly recommended to use UL mute feature, to squelch the uplink filter noise when there is no UL traffic. It is recommended to set the UL Mute threshold to be 10dB less than MIN\_UL\_INPUT in <Device - Overview> Page.

**Optimizing Downlink in Fiber DAS Mode**

The RF Switches can be turned ON or OFF from <Device - Batch Setting>, or individually in <Home>.

All RF Switch <input type="checkbox"/>			
UL RF Switch VHF	<input type="checkbox"/>	<input type="checkbox"/>	UL RF Switch UHF
DL RF Switch VHF	<input type="checkbox"/>	<input type="checkbox"/>	DL RF Switch UHF
DL Output ATT VHF	0	<input type="checkbox"/>	DL Output ATT UHF
UL Mute Switch VHF	<input type="checkbox"/>	<input type="checkbox"/>	UL Mute TH VHF
UL Mute Switch UHF	<input type="checkbox"/>	<input type="checkbox"/>	UL Mute TH UHF
UL Gain Limit VHF	85dB	<input type="checkbox"/>	UL Gain Limit UHF
Centralized Switch	OFF <input type="checkbox"/> ON <input type="checkbox"/>	<input type="checkbox"/>	
<a href="#">Batch Setting</a>			

Figure 153: Optimizing Fiber DAS – Batch Setting RF Switches and DL Output ATT

Use the same steps from the BDA section to optimize the Downlink for a Fiber DAS.

**Tips:**

- Set up the system on MU, using the same steps as the BDA, then batch set required DL Output ATT settings to all the RUs.
- If the MU and any RU need to have a different Downlink Output, adjust DL Output ATT individually for these devices.

If the required DL output is different for RUs, navigate to each unit to set individually.

**Example:**

8 channels in UHF

$$DL\_TAR = 30 - 10\log(8) = 21\text{dBm}$$

MU – requires 21dBm per channel

RU01 – requires 15dBm per channel

RU02 – requires 10dbm per channel

- Set all DL Output ATT = 0dB, as a reference point.
- Configure the DL\_TAR = 21dbm in <Device – Sites & Channels> page
- Keep MU DL **Output ATT = 0dB**, MU DL\_TAR will **remain 21dBm**.
- Change RU01 DL **Output ATT = 6dB**, it will reduce RU01 DL\_TAR **from 21dBm to 15dBm**.
- Change RU02 DL **Output ATT = 11dB**, it will reduce RU02 DL\_TAR **from 21dBm to 10dBm**.

**Optimizing Uplink in Fiber DAS**

The RF Switches can be turned ON or OFF from Batch Setting, or individually in <Home>.



Figure 154: Optimizing Fiber DAS – Batch Setting RF Switches, UL Mute, and UL Mute Threshold

Use the same steps from the BDA section to optimize the Uplink for a Fiber DAS.

In most cases, the **UL TAR should be the same setting** for all MU and RUs. If all MU and RU are designed to have the same input range (DAS UL Dynamic Range), then setting the same UL\_TAR and UL\_GAIN across all RUs is usually sufficient. (if you have RUs that do not have the same input range, adjust gain on individual devices in Home – RU pages)

The setting can be quickly done in the Batch Setting, including Gain Limit and Mute Settings.

UL Output ATT is a MU setting (but affects all MU and RUs) that must be set in <Device – Sites & Channels> or <Home – MU – Overview / Channels & Sites>.

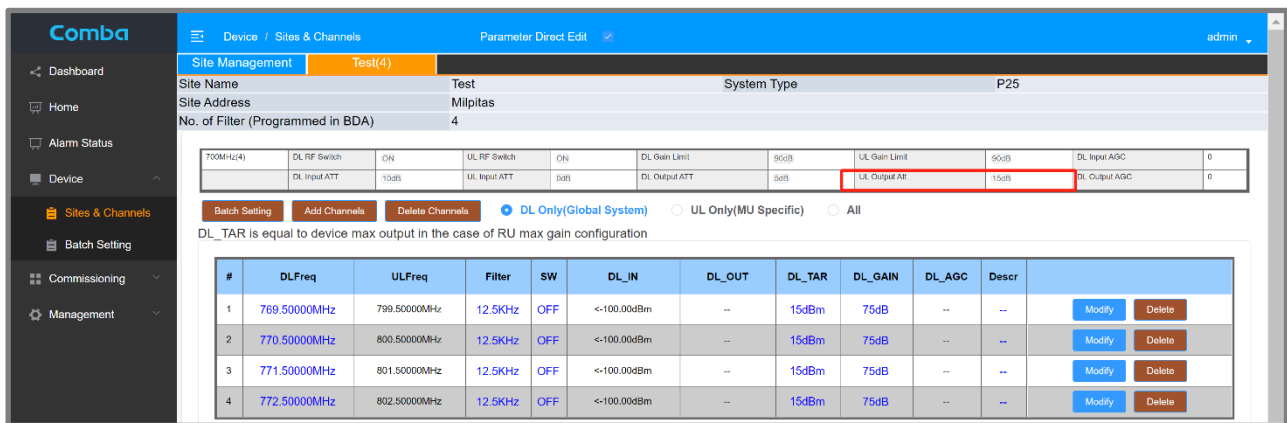

Figure 155: Optimizing Fiber DAS – Setting MU UL Output ATT

**UL Mute Function is highly recommended for all MU and RUs.**  
**NetProtect is NOT available in DAS mode in previous FW versions.** The firmware will disable this function automatically in DAS mode if it is not supported by the FW version.

### 3.30 COMMISSIONING FIBER DAS – PARAMETER SYNCHRONIZATION

#### DAS Internal Syncing

The following RF related parameters are **always synchronized** between Master Unit and Remote Unit. If you set these parameters at the Master Unit, the device will automatically configure the remotes with the same settings. These settings cannot be adjusted while accessing the remote unit directly.

Table 21: Commissioning Fiber DAS – Parameters Synchronized between Master and Remotes

Parameter	Set in
Sites	MU Main Menu – Device – Site & Channels
Filter Frequencies	MU Main Menu – Device – Site & Channels
Filter Bandwidth	MU Main Menu – Device – Site & Channels
Filter SW (Switch)	MU Main Menu – Device – Site & Channels
Filter (CH) Description	MU Main Menu – Device – Site & Channels
DL Channel Target Power Setting	MU Main Menu – Device – Site & Channels (Does NOT existing in RU)
DL Channel Individual Gain Setting	MU Main Menu – Device – Site & Channels (Does NOT existing in RU)

#### Sync Check

The Sync Check button can check if all the settings have been successfully synchronized to the Remote Units.

To perform a Sync Check:

- Navigate to <Dashboard – Table View> and click <Sync Check>.

Wait a few moments for the process to be completed. The result will be displayed at the corner of the Remote Unit. You will receive a “FAIL” if the parameters have not been synchronized properly. If this happens, wait a few minutes and try again. You will receive a “SUCC” if the parameters have been successfully synchronized. Once you have confirmed the parameters have synchronized, you can be confident all the remotes are configured.

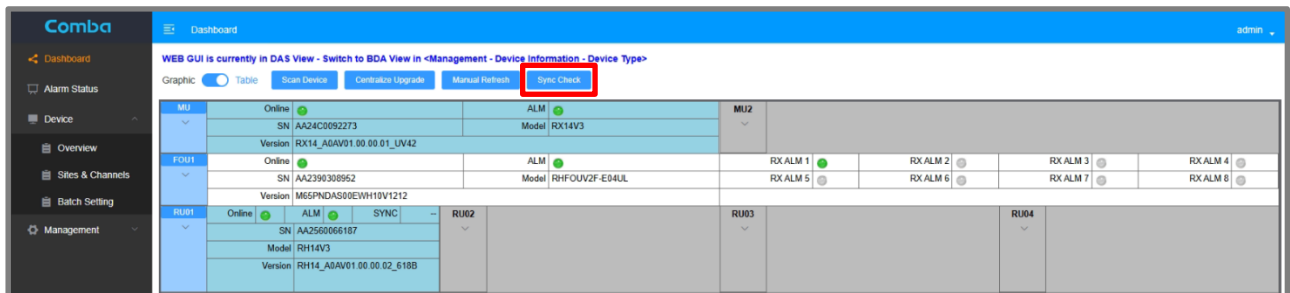

Figure 156: Commissioning Fiber DAS – Performing a Sync Check

The following RF related parameters are **NOT synchronized** between Master Unit and Remote Unit. Therefore, some MU and RU RF parameters **MUST** be set individually or using the Batch Setting. The easiest method is to use <Device - Batch Setting>. See Figure 157 for more details.

Table 22: Commissioning Fiber DAS – Parameters NOT Synchronized between Master and Remotes

Parameter	Function	Batch Setting
RF Switches	Control RF ON/OFF individually for each MU/RU	Main Menu - Batch Setting
Downlink Output ATT	<b>Control DL Output Power individually for each MU/RU</b>	Main Menu - Batch Setting
UL Channel Target Power Setting	Control CH UL Target Power individually for each MU/RU	Main Menu - Batch Setting
UL Channel Individual Gain Setting	Control CH UL Gain individually for each MU/RU	Main Menu - Batch Setting
UL Mute SW	Control Mute SW ON/OFF individually for each MU/RU	Main Menu - Batch Setting
UL Mute Threshold	Control Mute Threshold ON/OFF individually for each MU/RU	Main Menu - Batch Setting
UL Gain Limit (LNA Bypass)	Control <UL Gain Limit> individually for each MU/RU	Main Menu - Batch Setting

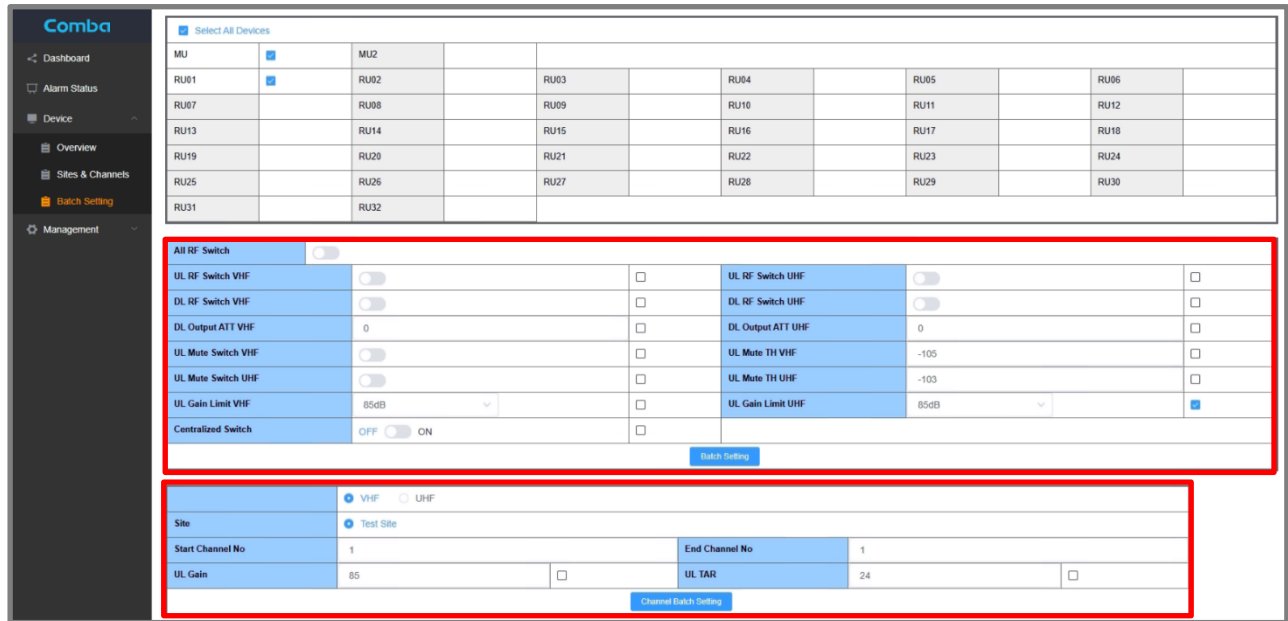

Figure 157: Commissioning Fiber DAS – Batch Settings for MU and RUs

### 3.31 ADVANCED SETTINGS – DL VSWR/RETURN LOSS MEASUREMENT

The BDA/MU and RU devices will monitor the DL VSWR/Return Loss measured at the Mobile Port (MT Port). In the Advanced Settings page of each device, the user can view the current DL VSWR/Return Loss readings to help validate the integrity of the mobile/service antenna branch. Should the DL Return Loss fall below 6dB, the device will generate an alarm indicating a problem detected with the passive DAS connected to the MT port.

To view the DL VSWR/Return Loss measurement table:

For BDA, navigate to <Device – Overview – Advanced Settings>  
 For Fiber DAS, navigate to <Home – Device Checkbox – Advanced>

Name	VHF DL	VHF UL	UHF UL	UHF DL	Actions
Forward Power	-110.33dBm	-119.76dBm	-119.05dBm	-123.86dBm	
Reflected Power	-89.41dBm	-99.91dBm	-107.29dBm	-108.1dBm	
Return Loss	-21.31dB	-18.72dB	-11.93dB	-15.81dB	
Return Loss TH	6dB	6dB	6dB	6dB	

Name	Value	Actions
NetProtect Switch	OFF	Modify
PA OFF Delay	3s	Modify
PA Protection Switch	OFF	Modify

Name	Value	Actions
Osc. Detection Switch	OFF	Modify

Name	Value	Actions
DT VHF ANT Disconnection Alarm	●	Modify
DT UHF ANT Disconnection Alarm	●	Modify

Name	Value	Actions
Noise Floor TH (Isolation Test)	-65dBm	Modify

Figure 158: Advanced Settings – DL VSWR/Return Loss Measurement Table

### 3.32 ADVANCED SETTINGS – NETPROTECT UL PA MUTING

NetProtect UL PA Muting will shut down the UL Power Amplifier when there is no UL traffic. During UL PA Shutdown, the BDA is not generating any UL output at all (Including No Noise). However, **it is highly recommended to measure the Broadband UL Noise Floor from the BDA DT port after the device has been commissioned and BEFORE turning on NetProtect.** This allows the technician to evaluate the UL Noise Performance without the impact of NetProtect.

To configure NetProtect UL PA Muting:

- For BDA, navigate to <Device – Overview – Advanced Settings>  
For Fiber DAS, navigate to <Home – Device Checkbox – Advanced>
- Click <Modify> in the <NetProtect Switch> row to Turn ON or OFF NetProtect UL PA Muting.
- Click <Modify> in the <PA OFF Delay> row to adjust the delay time before the UL PA will mute. The default setting is 3s and the MAX setting is 3600 seconds (1hr).

Note: NetProtect UL PA Muting may not be supported in Fiber DAS configurations with older FW versions.

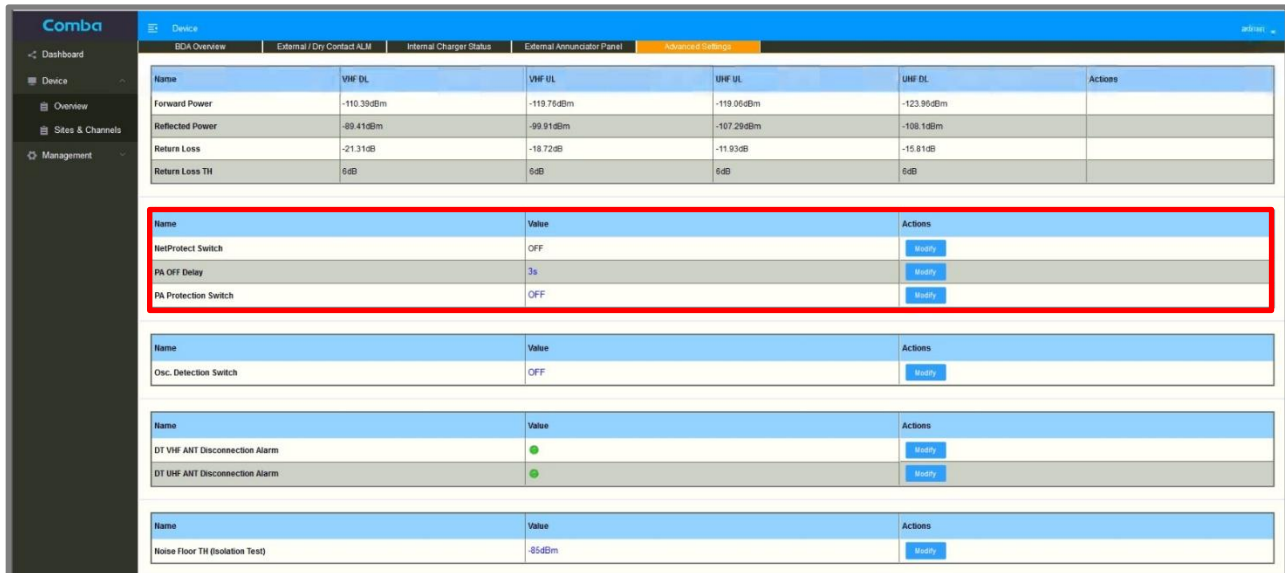

Name	VHF DL	VHF UL	UHF UL	UHF DL	Actions
Forward Power	-110.39dBm	-119.76dBm	-119.06dBm	-123.96dBm	
Reflected Power	-89.41dBm	-99.81dBm	-107.29dBm	-108.1dBm	
Returns Loss	-21.31dB	-18.72dB	-11.93dB	-15.81dB	
Returns Loss TH	6dB	6dB	6dB	6dB	

Name	Value	Actions
NetProtect Switch	OFF	<a href="#">Modify</a>
PA OFF Delay	3s	<a href="#">Modify</a>
PA Protection Switch	OFF	<a href="#">Modify</a>

Name	Value	Actions
Osc. Detection Switch	OFF	<a href="#">Modify</a>

Name	Value	Actions
DT VHF ANT Disconnection Alarm	●	<a href="#">Modify</a>
DT UHF ANT Disconnection Alarm	●	<a href="#">Modify</a>

Name	Value	Actions
Noise Floor TH (Isolation Test)	-85dBm	<a href="#">Modify</a>

Figure 159: Advanced Settings – NetProtect UL PA Muting

### 3.33 ADVANCED SETTINGS – GAIN LIMIT / LNA BYPASS

The Gain Limit / LNA Bypass feature is like having two types of BDAs in one, a low gain version and a high gain version. The Gain Limit allows the user to reduce the MAX Gain of the system from 85dB to 60dB. The default setting is 85dB. If the system requires between 60dB to 85dB of Gain in both the DL and UL paths, then there is no need to adjust the Gain Limit parameter. If the system requires less than 60dB of Gain in either the DL or UL paths, the user can use the Gain Limit / LNA Bypass feature to limit the MAX Gain to 60dB. The BDA/DAS System accomplishes this by bypassing one of the internal input LNAs and therefore reducing the overall gain in the chain by 25dB. See Figure 160 for more details.

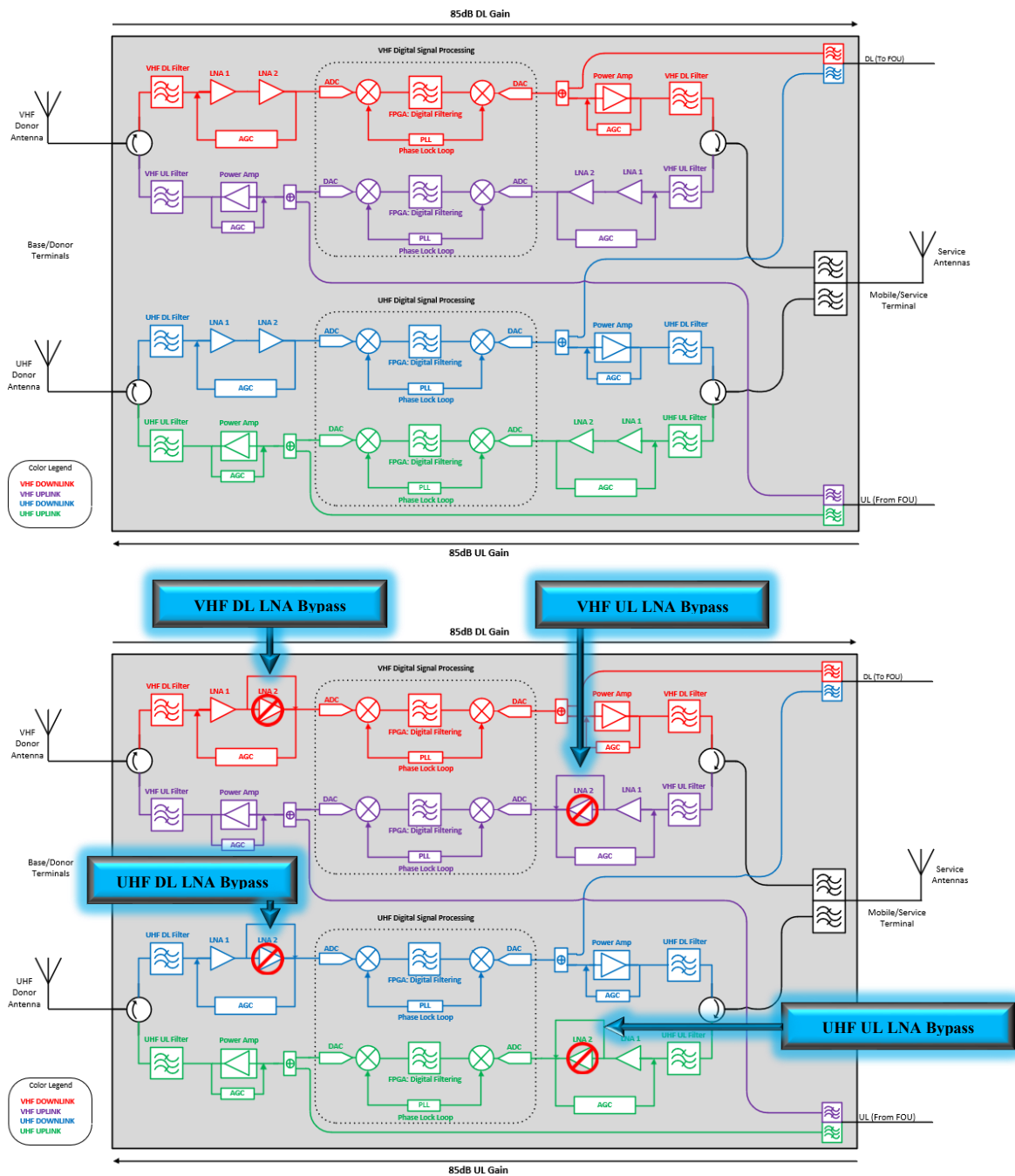

Figure 160: Advanced Settings – Gain Limit / LNA Bypass

To modify the Gain Limit:

- For BDA, Navigate to <Device – Overview – Gain Limit>
- For MU, navigate to <Home – MU Checkbox – Overview – Gain Limit>
- For RU, navigate to <Home – RU Checkbox – Overview – Gain Limit>
- Click <Modify> in the UL Gain Limit(VHF), UL Gain Limit(UHF), DL Gain Limit(VHF), or DL Gain Limit(UHF) rows to change the Gain Limit from 85dB to 60dB.

Alternatively, the Gain Limit can be adjusted in the <Site and Channels> page for each device in the window above the filter section. Furthermore, the UL Gain Limit is available in the <Device – Batch Settings> section for when in Fiber DAS mode so the user can Batch Set the UL Gain Limit settings to all RUs in the system if desired. See Figure 161 below.

**BDA/MU/RU  
<Advanced Settings>  
DL/UL Gain Limit**

Name	VHF DL	UHF DL	VHF UL	UHF UL	Actions
RF Switches	OFF	OFF	OFF	OFF	Modify
P_in(Composite)	-120.00dBm	-120.00dBm	-120.00dBm	-108.77dBm	
P_out(Composite)	-116.31dBm	-126.97dBm	-125.63dBm	-125.77dBm	
Target Output Power	24dBm	30dBm	24dBm	27dBm	Modify
Input ATT	0dB	0dB	0dB	0dB	Modify
Output ATT	0dB	0dB	0dB	0dB	Modify
Mute Switch	OFF	ON	ON	OFF	Modify
Mute TH	-105dBm	-105dBm	-105dBm	-105dBm	Modify
PA_Status	Normal	Normal	Normal	Normal	
Gain Limit	85dB	85dB	85dB	85dB	Modify
P_in Low					Modify
P_in Low TH	-90	-90			Modify
P_out Low					Modify
P_out Low TH	-6	-6			Modify
P_in Over					Modify
P_in Over TH	-30	-30			Modify
P_out Over					Modify
P_out Over TH	27dBm	33dBm	27dBm	30dBm	Modify
LNA Alarm					Modify
PA Alarm					Modify
PA Shutdown Alarm					Modify
VSWR Alarm					Modify

**BDA/MU/RU  
<Sites & Channels>  
DL/UL Gain Limit**

#	DL Freq	UL Freq	Filter	SW	DL_IN	DL_OUT	DL_TAR	UL_TAR	UL_IN	UL_OUT	DL_GAIN	UL_GAIN	DL_AGC	UL_AGC	Descr	Actions
1	759.50000MHz	759.50000MHz	25KHz	ON	<-110.00dBm	<-7.00dBm					85dB	0	0			Modify Delete
2	770.00000MHz	800.00000MHz	25KHz	ON	<-110.00dBm	<-7.00dBm					85dB	0	0	Control		Modify Delete
3	770.50000MHz	800.50000MHz	25KHz	ON	<-110.00dBm	<-7.00dBm					85dB	0	0			Modify Delete

**Fiber DAS  
<Device Batch Setting>  
UL Gain Limit**

All RF Switch	OFF <input type="checkbox"/> ON <input type="checkbox"/>		DL RF Switch 800MHz	OFF <input type="checkbox"/> ON <input type="checkbox"/>	UL RF Switch	OFF <input type="checkbox"/> ON <input type="checkbox"/>
DL RF Switch 700MHz	OFF <input type="checkbox"/> ON <input type="checkbox"/>		DL Output ATT 800MHz			
DL Output ATT 700MHz	0					
UL Mute Switch	OFF <input type="checkbox"/> ON <input type="checkbox"/>		UL Mute TH(dBm)			
UL Gain Limit	90dB					
OP Redundancy Mode	Manual		OP Port Force Switching			

Figure 161: Setting Gain Limit / LNA Bypass in WEB GUI

### 3.34 ADVANCED SETTINGS - OSCILLATION DETECTION AND ALARMS

Oscillation Detection is a mechanism used by the system to detect when an RF feedback oscillation loop is occurring due to low isolation between the rooftop donor antenna and indoor service antennas. An oscillating BDA/DAS can cause major issues to outdoor radio networks as well as damage the device itself. The oscillation detection mechanism is used to detect and mitigate oscillations if they occur and generate a supervisory alarm. The Oscillation Detection mechanism and Alarms are disabled by default to prevent false alarms or inadvertent system shutdown from occurring during initial commissioning and testing phases.

See the following procedure for instructions to enable and configure the Oscillation Detection and Alarms:

- For BDA Mode, Login to the BDA/MU and navigate to <Device – Overview – Advanced Settings>. For DAS Mode, Login to the BDA/MU and navigate to <Home – MU/RU Checkbox – Advanced>.
- Click on <Modify> in the <Osc. Detection Switch> row. Click on the Osc. Detection Switch to change from OFF to ON and click <Save> to enable the Oscillation Detection and Alarms. Wait for window to refresh to view and access the oscillation alarm parameters. <Modify> parameters accordingly.

The screenshot displays the 'Advanced Settings' page for a device. A modal window titled 'Setting' is open, showing the 'Osc. Detection Switch' being toggled from OFF to ON. Below the modal, a table lists various settings. The 'Osc. Detection Switch' row is highlighted with a red box, and a blue callout box with an arrow points to its 'Modify' button, with the text 'Click Modify to turn on Oscillation Detection'.

Name	Value	Actions
NetProtect Switch	OFF	Modify
PA OFF Delay	3s	Modify
PA Protection Switch	OFF	Modify
<b>Osc. Detection Switch</b>	<b>OFF</b>	<b>Modify</b>
DT VHF ANT Disconnection Alarm	●	Modify
DT UHF ANT Disconnection Alarm	●	Modify
Noise Floor TH (Isolation Test)	-65dBm	Modify

Figure 162: Advanced Settings – Enabling Oscillation Detection, Shutdown, and Alarms

#### **Once Oscillation Detection has been enabled:**

The system will have two additional alarms which are configured into Dry Contact Alarms

#### **Oscillation Gain Reduction (VHF or UHF) Alarm**

- Oscillation detected; the system is currently still running but with reduced gain.

#### **Oscillation Shutdown (VHF or UHF) Alarm**

- Oscillation detected; the RF Switches automatically turn OFF as gain cannot be reduced further to mitigate oscillation/isolation issue.

**Once Oscillation Gain Reduction Alarm or Shutdown Alarm is triggered, it will NOT clear itself. The User must clear the alarm manually in <Tools> Oscillation Reset and PA Reset and then troubleshoot the oscillation/isolation issue before attempting to turn the system back on!**

**Oscillation Detection Process**

Once an oscillation is detected, the system will measure the current isolation. If the gain > isolation – 20, system will reduce the gain and generate an Oscillation Gain Reduction alarm. If gain < isolation - 20, the system moves to the **T2 judgement process** to monitor the parameters. If oscillation continues to be detected, the system will shut down and generate an Oscillation Shut Down Alarm. See Figure 163 and Table 23 below for a detailed explanation of the Oscillation Detection parameters.

Name	Value	Actions
Osc. Detection Switch	ON	<a href="#">Modify</a>
UL Switch	ON	<a href="#">Modify</a>
DL Switch	OFF	<a href="#">Modify</a>
UL_OSC_TH	-70dBm	<a href="#">Modify</a>
DL_OSC_TH	-30dBm	<a href="#">Modify</a>
OSC_T1(2s)	20	<a href="#">Modify</a>
OSC_T2(min)	10	<a href="#">Modify</a>
OSC_T2_CycleNum	12	<a href="#">Modify</a>
VHF DL Last Isolation Mea.	127dB	
UHF DL Last Isolation Mea.	127dB	
Oscillation Shutdown(VHF)		<a href="#">Modify</a>
Oscillation Shutdown(UHF)		<a href="#">Modify</a>
Oscillation Gain Reduction(VHF)		<a href="#">Modify</a>
Oscillation Gain Reduction(UHF)		<a href="#">Modify</a>

Figure 163: Oscillation Detection Alarm Parameters

Table 23: Oscillation Detection Parameters Explained

	Default	
Osc. Detection Switch	OFF	The switch to turn on or off Oscillation Detection
UL Switch	ON	The switch to turn on or off the UL Oscillation Detection
DL Switch	OFF	The switch to turn on or off the DL Oscillation Detection
UL_OSC_TH	-70	UL Oscillation Threshold Level. Refer to OSC_T1 (2s)
DL_OSC_TH	-30	DL Oscillation Threshold Level. Refer to OSC_T1 (2s)
OSC_T1(2s)	20	The <b>Oscillation Detection Process</b> will start if UL or DL composite input power is higher than UL_OSC_TH or DL_OSC_TH for longer than OSC_T1 (2s).
OSC_T2(min) <b>(T2 Judgement Process)</b>	10	If the input power is still higher than UL_OSC_TH or DL_OSC_TH after isolation measures OK, the system will confirm the high input status and restart the oscillation detection at every OSC_T2 (min) period
OSC_T2_CycleNum	12	The total number of times the system will retry the detection process if isolation is measuring OK, but input power is still high. If high input is cleared, the process will end. If the retry attempts > OSC_T2_CycleNum value, the system will generate PA shutdown and turn OFF the RF Switches
VHF DL Last Isolation Mea.		The last measured isolation for VHF band for reference
UHF DL Last Isolation Mea.		The last measured isolation for UHF band for reference
Oscillation Shutdown(VHF)	Enabled	VHF Band has been shut down; failure to mitigate oscillation
Oscillation Shutdown(UHF)	Enabled	UHF Band has been shut down; failure to mitigate oscillation
Osc. Gain Reduction(VHF)	Enabled	VHF band Gain is reduced due to oscillation
Osc. Gain Reduction(UHF)	Enabled	UHF band Gain is reduced due to oscillation

### 3.35 ADVANCED SETTINGS – DONOR ANTENNA ALARMS

There are two different mechanisms to monitor the Donor Antenna. The Donor Antenna Disconnection alarm and the P\_IN LOW Alarm. The user can choose which of these two alarms they would like to use. Furthermore, both alarms can be configured to work together if the user desires. The factory default settings will have the Donor Antenna Disconnection alarm enabled and the P\_IN LOW alarm disabled.

The Donor Antenna Disconnection Alarm configuration is found in the Advanced Settings page of the BDA or MU. This alarm is designed to provide a DT Disconnection Alarm upon sensing a disconnection of cabling between the BDA and rooftop Donor Antenna. The alarm can be enabled or disabled from this area. This alarm works independently per band by using an internal Bias-T connected to each DT Port. For this mechanism to work properly, the RF cabling and passive components between the BDA DT Port and the Rooftop Donor antenna must all be designed to pass DC. The Donor Antenna itself should be DC shunt to Ground. If the Donor Antenna is not DC Shunt to Ground, the integrator can use the provided Bias-T kit with a 50Ω Load Termination installed as close to the Donor Antenna as possible to complete the monitoring circuit.

#### **Bias-T Maximum Ratings**

Operating Temperature: -55° C to 100° C

Storage Temperature: -55° C to 100° C

Input Current: 500mA

RF Power: 30 dBm (1W)

Voltage at DC Port: 30V

Permanent damage may occur if any of these limits are exceeded!

The P\_IN LOW Alarm configuration is found in the BDA Overview page of the BDA or MU. This alarm is designed to provide a P\_IN LOW Alarm when the DL Composite Input Power “P\_IN(Composite)” detected by the BDA is below the user defined threshold “P\_IN LOW TH”. The user should optimize this alarm such that the Average Composite DL Input Levels always remain above the user set “P\_IN LOW TH”. When the Donor Antenna experiences a disconnection or a malfunction, the BDA will trigger the “P\_IN LOW” alarm when the detected DL Composite Input Power drops below the “P\_IN LOW TH”.

To configure the Donor Antenna Disconnection alarm:

- For BDA, navigate to <Device – Overview – Advanced Settings>  
For MU, navigate to <Home – MU Checkbox – Advanced>
- Click on <Modify> in <DT ANT Disconnection Alarm> row to Enable/Disable the alarm.

Note: During the initial system turn up and commissioning, the user may choose to temporarily disable this DT ANT Disconnection alarm to prevent false nuisance alarms from occurring. See Figure 164 below.

To configure the P\_IN LOW alarm and P\_IN LOW TH threshold:

- Navigate to BDA Overview page. Click on <Modify> in <P\_IN LOW> row to Enable/Disable the alarm.
- From the same BDA Overview page, monitor the DL P\_IN(Composite) reading for each band for a few minutes and try to determine an average based on the traffic the BDA experiences. Set the P\_IN LOW TH 10-20dB below the average P\_IN(Composite) level.
- Click on <Modify> in the <P\_IN LOW TH> row. Modify value accordingly. See Figure 164 below.

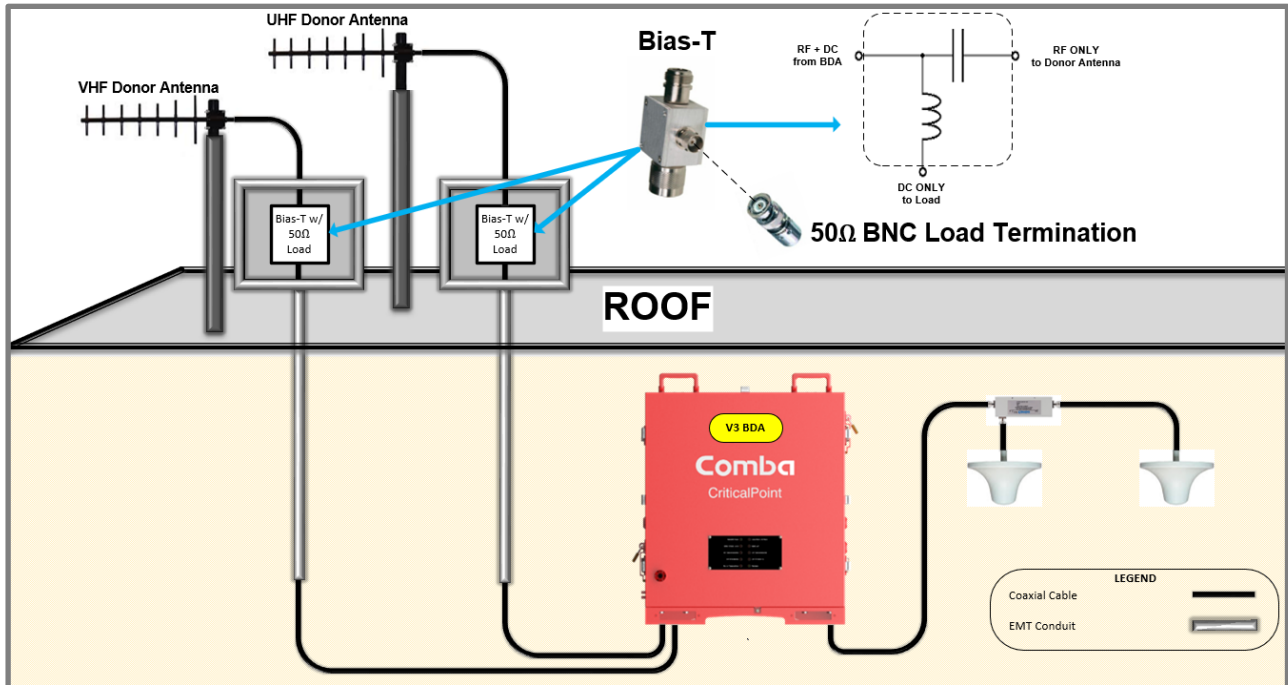

BDA Overview					
External / Dry Contact ALM		Internal Charger Status		External Annunciator Panel	
Name	VHF DL	VHF UL	UHF UL	UHF DL	Actions
Forward Power	-110.39dBm	-119.76dBm	-119.06dBm	-123.96dBm	
Reflected Power	-89.41dBm	-99.91dBm	-107.29dBm	-108.1dBm	
Returns Loss	-21.31dB	-18.72dB	-11.93dB	-15.81dB	
Returns Loss TH	6dB	6dB	6dB	6dB	

Name	Value	Actions
NetProtect Switch	OFF	Modify
PA OFF Delay	3s	
PA Protection Switch	OFF	

Name	Value	Actions
Osc. Detection Switch	OFF	

Name	Value	Actions
DT VHF ANT Disconnection Alarm	●	Modify
DT UHF ANT Disconnection Alarm	●	Modify

Click Modify to Enable/Disable VHF and UHF DT Antenna Disconnection Alarms

BDA Overview					
External / Dry Contact ALM		Internal Charger Status		External Annunciator Panel	
Name	VHF DL	UHF DL	VHF UL	UHF UL	Actions
RF Switches	OFF	OFF	OFF	OFF	Modify
P_in(Composite)	-129.00dBm			-108.83dBm	
P_out(Composite)	-115.64dBm			-125.80dBm	
Target Output Power	24dBm			27dBm	
Input ATT	0dB			0dB	
Output ATT	0dB			0dB	
Mute Switch	OFF			OFF	
Mute TH	-105dBm			-105dBm	
PA_Status	Normal			Normal	
Gain Limit	85dB			85dB	
P_in Low	●	●			Modify
P_in Low TH	-90	-90			Modify

Setting VHF DL

\* P\_in Low TH(dBm) -60

---

Setting UHF DL

\* P\_in Low TH(dBm) -60

Save Cancel

Click Modify to Enable/Disable P\_IN LOW alarm and set P\_IN LOW TH threshold

Figure 164: Advanced Settings – DT Donor Antenna Disconnection and P\_IN LOW Alarm

### 3.36 TOOLS (DEVICE RESET / ALARM LOG / REPORT)

There are multiple tools available in the <Management – Tools> page of the GUI.

Follow the instructions below to access the Tools page of the GUI:

- For BDA or MU, Login to the BDA/MU and navigate to <Management – Tools>.  
For DAS RU, Login to the BDA/MU and navigate to <Dashboard – Table Style - MU/RU Checkbox – Tools>.

See Figure 165 and Table 24 below for a detailed explanation of the available tools.

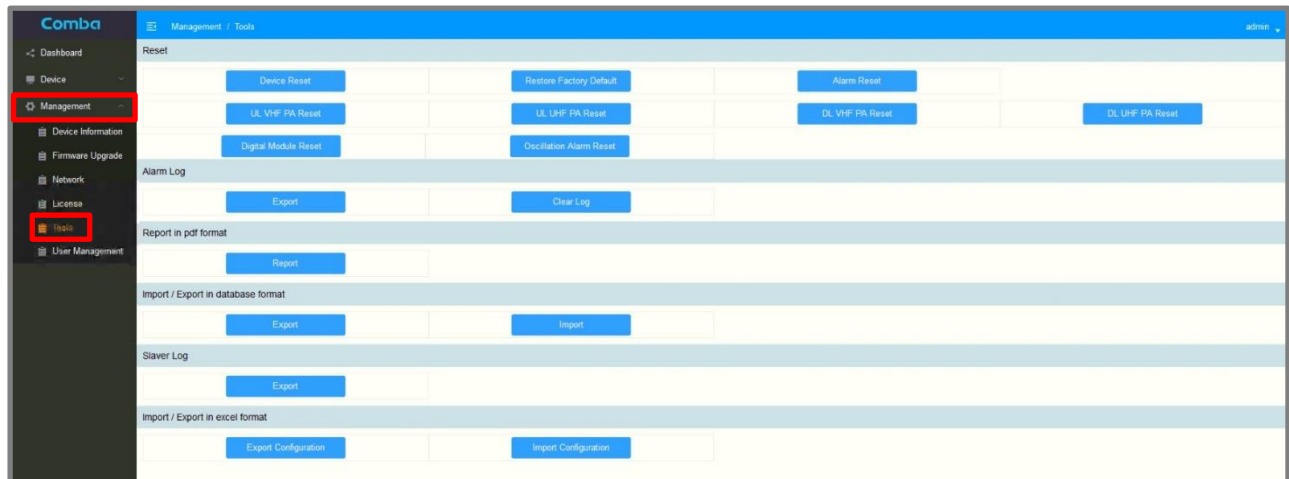

Figure 165: Management – Tools (Device Reset/Alarm Log/Reports)

Table 24: Management – Tools Explained (Device Reset/Alarm Log/Reports)

Tool Type	Tool and Explanation
Reset	Device Reset: Reset device controller. Digital Module Reset: Reset device digital FPGA board. DL VHF PA Reset: Reset VHF Downlink Power Amplifier. DL UHF PA Reset: Reset UHF Downlink Power Amplifier. UL VHF PA Reset: Reset VHF Uplink Power Amplifier. UL UHF PA Reset: Reset UHF Uplink Power Amplifier. Alarm Reset: Temporarily Clear all alarms Oscillation Alarm Reset: Clear oscillation alarms. Restore Factory Default: Reset to factory default settings.
Alarm Log	Export: Export Alarm log of BDA/MU/RU individually Clear Log: Clear Alarm log
Report in pdf format	Report: Generate a pdf report documenting system settings If BDA is in DAS Mode, MU can generate reports for each device in the system.
Import / Export in database format	Export / Import BDA/MU/RU configuration individually in database format.
Slaver Log	Use only when requested by Comba Tech Support
Import / Export in excel format	Export / Import BDA/MU/RU configuration individually in excel format.

End of Section

## 4 FIRMWARE UPGRADES

It is recommended to download the latest firmware before commissioning. Check [www.combause.com/downloads](http://www.combause.com/downloads) to download the latest firmware releases.

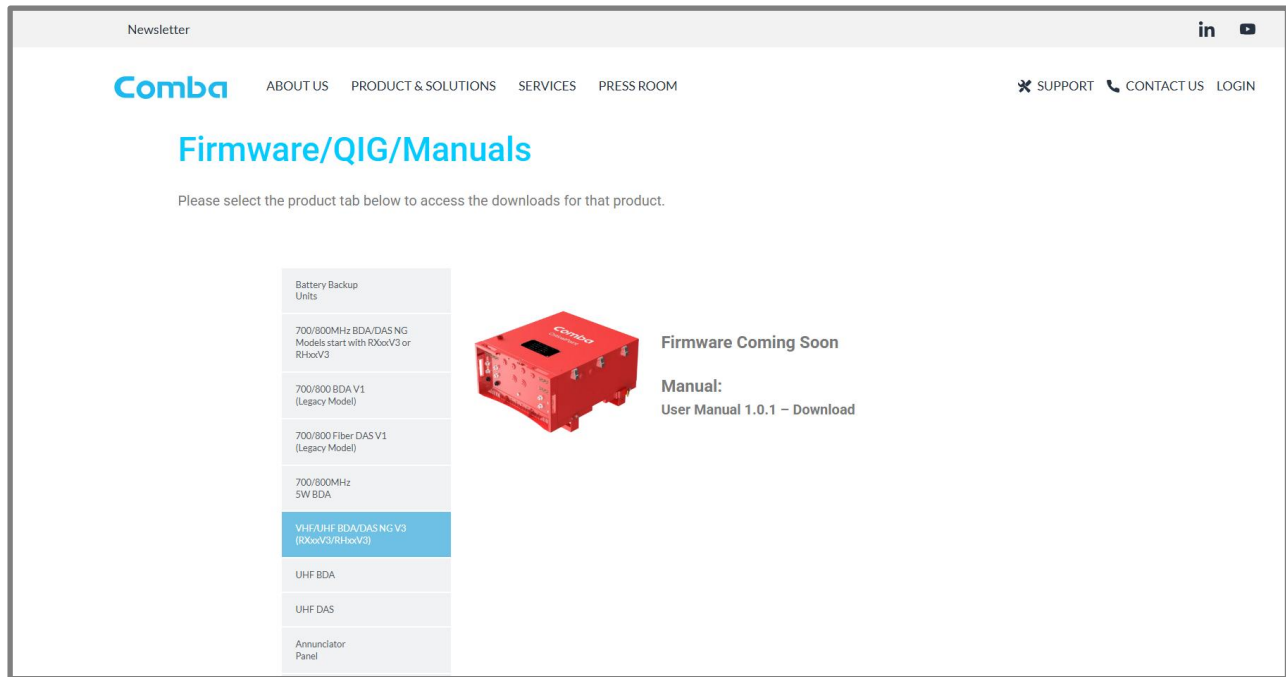

Figure 166: Comba Firmware Downloads Webpage

### 4.1 V3 BDA/MU FIRMWARE UPGRADE

**Note:** When using the device in Fiber DAS mode, always perform the firmware upgrade on the BDA/MU first and then proceed to upgrade the FOU's and RUs.

1. Login to the OMT or LAN port and go to Management -> Firmware Upgrade.
  2. Click <Select File> and select the firmware file. Then click <Upgrade>.
  3. A progress window will pop up. Once the upgrade has been completed you will receive a success message. Click <Finish> after completion.
  4. The device will take approximately 2-4 minutes to reboot after the upgrade.
- Upgrading the firmware will only terminate the RF service during the final reset after firmware is deployed (RF is restored within approximately 30 seconds after reset).
  - Upgrades can also be done from the web using a remote IP connection.
  - There is slave module firmware that is packed within the same main firmware. Slave module upgrades will start automatically in the background. The table below will show the slave module version and the upgrade progress. While they are still upgrading, some features may not function properly. Other functions such as <Slaver Upgrade> are only for Comba Support to use.

The screenshot displays the 'Local Upgrade' interface in the Comba OMT. At the top, the breadcrumb navigation shows 'Management / Firmware Upgrade'. The main content area is titled 'Local Upgrade' and contains a summary box with the following information:

- Dev Model: RX14V3
- System Version: RX14\_AGAV01.00.00.01\_UV42
- Buttons: Select File (blue), Upgrade (green)

Below this summary is a table showing the upgrade progress for various modules. The table has five columns: Module, Current Version, Target Version, Update Status, and Next Status.

Module	Current Version	Target Version	Update Status	Next Status
Distribution Board Module	M55RX1122D7WH10V5419	M55RX1122D7WH10V5419	Success	None
APV1-1	--	--	--	--
APV1-2	--	--	--	--
Charger	EPA390ACOMBAEDA0013	--	--	--
APV3-BDA-1	--	--	--	--
APV3-BDA-2	--	--	--	--
APV3-DAS-1	M52ETCCPANAFIIV1410	M52ETCCPANAFIIV1410	Success	None
APV3-DAS-2	--	--	--	--
APV3-DAS-3	--	--	--	--
APV3-DAS-4	--	--	--	--

Figure 167: BDA/MU Local Firmware Upgrade Process

## 4.2 V2 FOU AND V3 RU FIRMWARE UPGRADE EXPLANATION

For the FOU and RU, firmware can be upgraded locally or can be deployed over the fiber from the Master Unit.

- Performing a local upgrade to an FOU or RU is the same basic process as described above for the BDA/MU and must be performed by connecting directly to the device OMT port with a computer and ethernet RJ45 cable. Any urgent firmware upgrade is recommended to be done locally as deploying the firmware over fiber from the BDA/MU takes a longer time.
- To upgrade the FOU or RU firmware from the BDA/MU, the FOU and/or the Remote Unit must first be discovered by the Master Unit by performing a scan in the Dashboard screen Dashboard -> Graphic -> Scan. While the FOU upgrade is quite fast (5-10 minutes), the firmware upgrades for RUs are much slower due to deploying the firmware data over the fiber link. Each RU can take approximately 25-35 minutes to upgrade. Furthermore, when deploying new firmware to multiple RUs using the Centralize Upgrade feature, the firmware is deployed one RU at a time in series. The total upgrade time can become quite long. See Figure 168 below.



Figure 168: V3 BDA/MU Dashboard Scan for FOU and RU

### 4.3 V2 FOU LOCAL FIRMWARE UPGRADE

1. Login to the FOU via OMT port.
2. In Management -> Upgrade, switch OFF <Centralized Download Switch>.
3. Click <Select File> and select the firmware file. Then click <Upgrade>.
4. A progress window will pop up. Once the upgrade has been completed you will receive a success message. Click <Finish> after completion.
5. The device will take approximately 2-4 minutes to reboot after the upgrade.

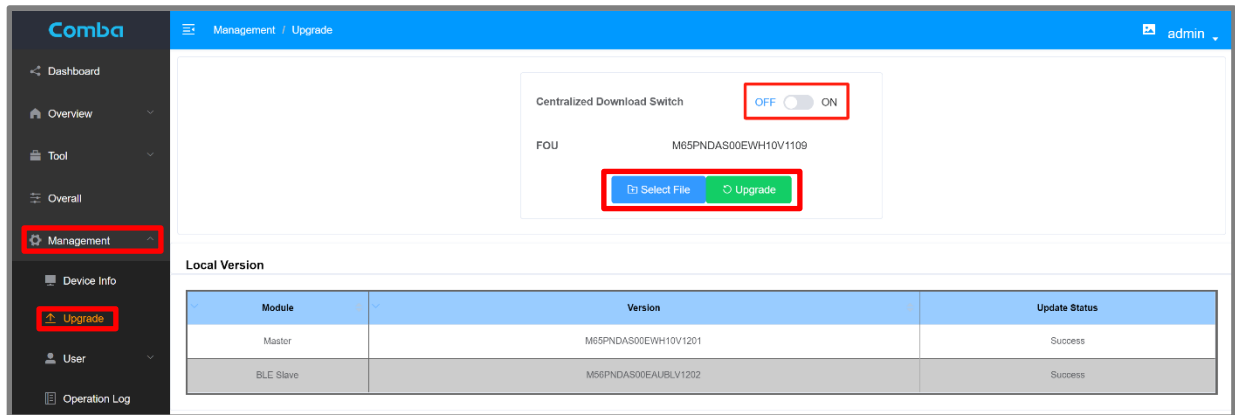

Figure 169: V2 FOU Local Firmware Upgrade

### 4.4 V3 RU LOCAL FIRMWARE UPGRADE

1. Login to the RU OMT port and go to Management -> Firmware Upgrade.
2. Click <Select File> and select the firmware file. Then click <Upgrade>.
3. A progress window will pop up. Once the upgrade has been completed you will receive a success message. Click <Finish> after completion.
4. The device will take approximately 2-4 minutes to reboot after the upgrade.

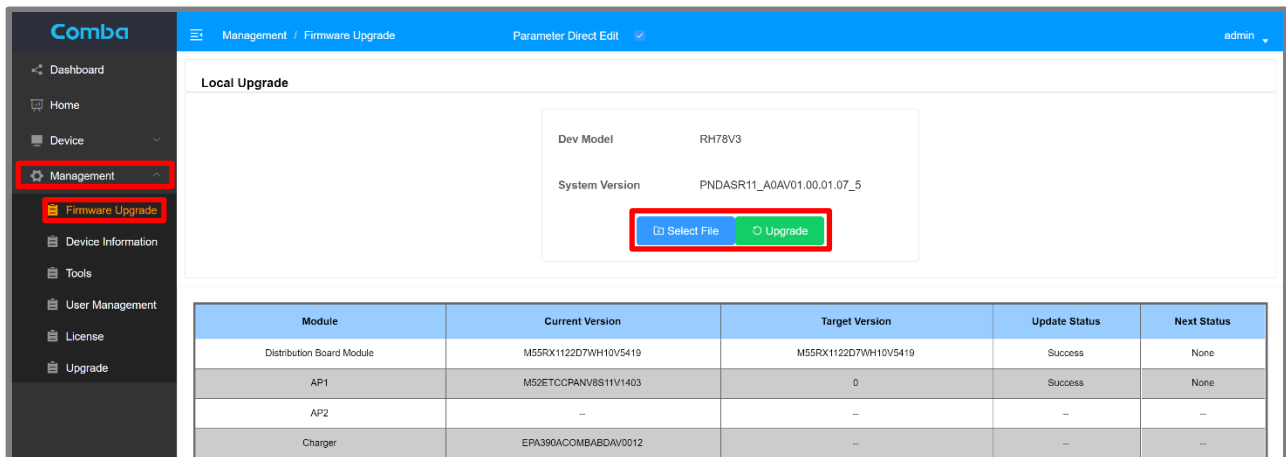

Figure 170: V3 RU Local Firmware Upgrade

### 4.5 V2 FOU AND V3 RU FIRMWARE UPGRADE FROM BDA/MU

- You must use <Centralized Upgrade> feature to upgrade FOU and RU firmware from the BDA/MU. (Attempting to upgrade the firmware from FOU or RU device pop-up pages by clicking the device in Table View will NOT work.)

**Preparation – Turn ON <Centralized Download Switch> on ALL devices, skip if they are already ON**

1. Complete scan and discover all devices. Dashboard -> Table > Scan
2. Click on FOU to access FOU pop-up window.

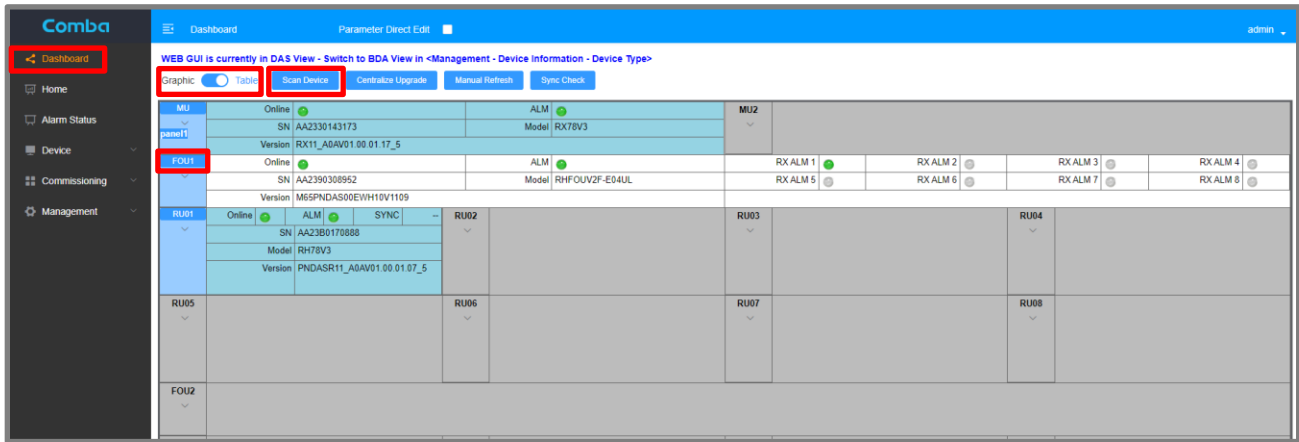

Figure 171: V3 BDA/MU Dashboard Scan and FOU Access

3. In the pop up FOU page, go to Management -> Upgrade, and **turn ON <Centralized Download Switch>**. If there are multiple FOU, complete this step one by one for each FOU. Then exit the FOU page.

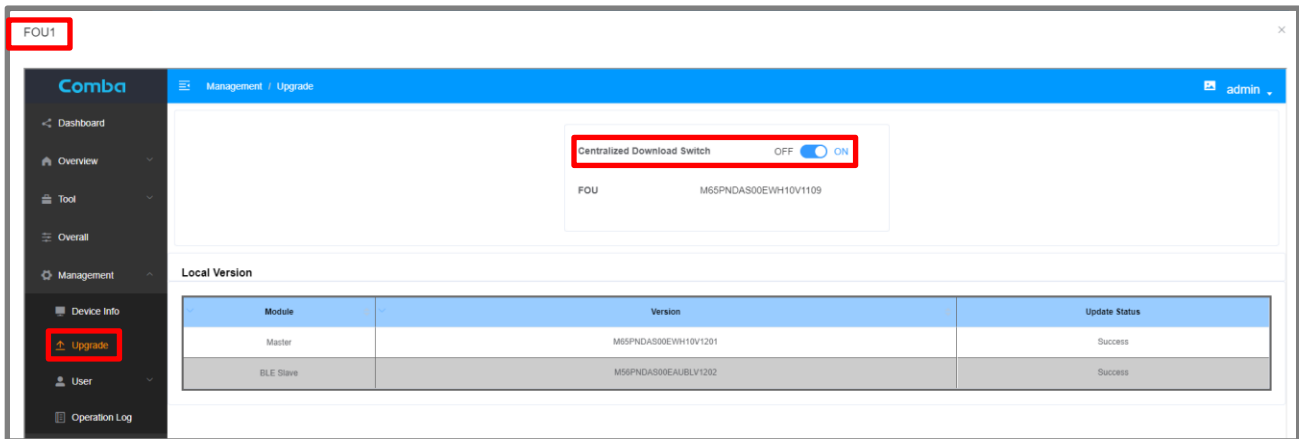

Figure 172: V2 FOU Centralized Download Switch

- In the BDA/MU main menu, go to Device -> Batch Setting, turn ON <Centralized Switch>. Make sure to select the devices that need to be upgraded at the top table, and the <Centralized Switch> is checked. Then click on the <Batch Setting> button. There is a pop-up that indicates the operation is successful.

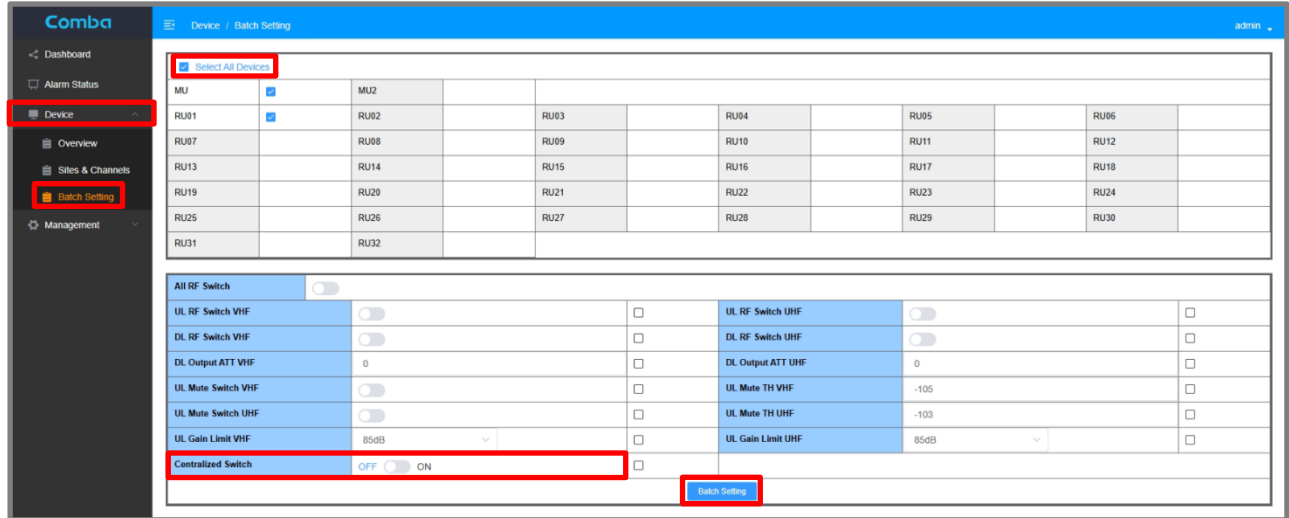

Figure 173: Batch Setting RU Centralized Download Switch

### FOU and RU Centralized Upgrade

- In the <Dashboard> Page, click <Centralize Upgrade> button. Both the FOU and RU can be upgraded here. You can only upgrade FOU or RUs but not at the same.

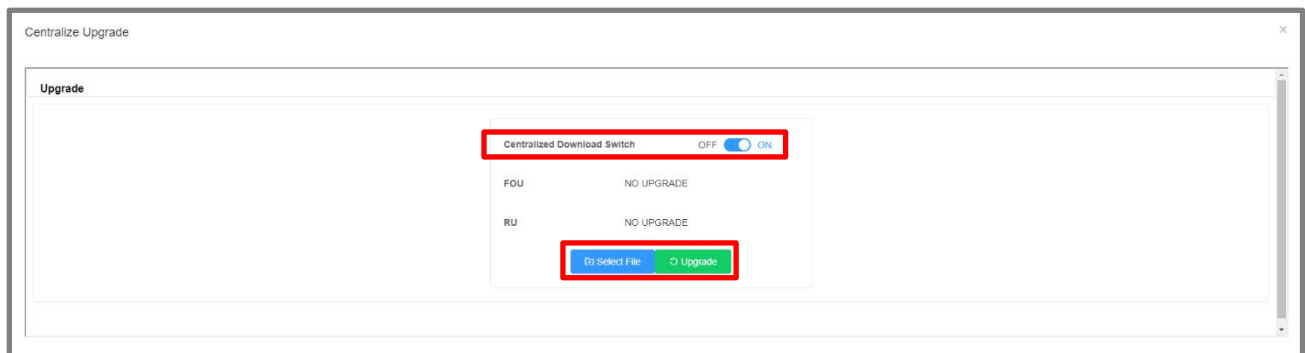

Figure 174: V3 BDA/MU Dashboard Centralized Upgrade Pop-up Window

## 2. Upgrade FOUs

- Click <Select File>, select the FOU firmware and then click the <Upgrade> button. This will upgrade all FOU automatically. After a few seconds, you will receive a success message. Click <confirm> and wait while the firmware is deployed in the background. The firmware can take 10-15 minutes to deploy to the FOUs. It is recommended to validate that all FOUs have been upgraded before performing the centralized upgrade for the RUs.

## 3. Check upgrade progress.

It is recommended to complete the FOU upgrades first, which normally takes a short time. Confirm all FOUs have been upgraded to the expected version. Then apply the upgrades to the RUs.

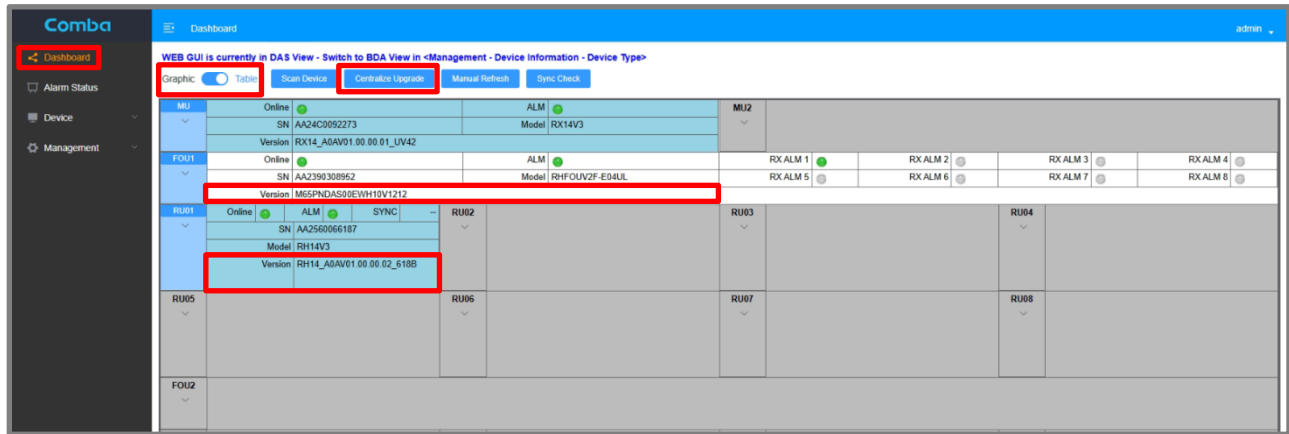

Figure 175: V3 BDA/MU Dashboard Firmware Validation

## 1. Upgrade RUs

The upgrade for each RU is done over fiber and in series and the system will skip the upgrade if the target device already has the same firmware. Large systems of RUs can take a long time to upgrade.

**Note: Once you have started the centralized upgrade process for the RUs, local upgrades to RUs can still be completed at the same time. In other words, the system will automatically deploy firmware to RUs while a user at the site can deploy firmware locally to the same system of the RUs. This can reduce the overall time to upgrade a large system of RUs.**

- Dashboard -> Centralize Upgrade. Click <Select File>, select the RU firmware and then click the <Upgrade> button. This will upgrade all RU automatically. After a few seconds, you will receive a success message. Click <confirm> and wait while the firmware is deployed in the background. Each RU firmware upgrade will take approximately 25-35 minutes to complete.
- Check progress in the Dashboard -> Table view by validating correct firmware versions.

End of Section

## 5 ALARMS, TROUBLESHOOTING, AND MAINTENANCE

The V3 system alarms can be configured in many ways depending on the local code requirements. This section of the user manual will provide an overview of the V3 system alarm operation, default alarm configuration, alarm LED indicators, buzzer indicators, GUI alarm indicators and settings, alarm wiring, and more.

### 5.1 V3 BDA/MU/RU LED INDICATORS, BUZZER, AND LAMP TEST

The BDA/MU/RU LED indicators help the user to check the equipment status quickly and easily. The LED status indicators mirror the dry contact alarm outputs. See below Figure 176 and Table 25 which explain their operation.

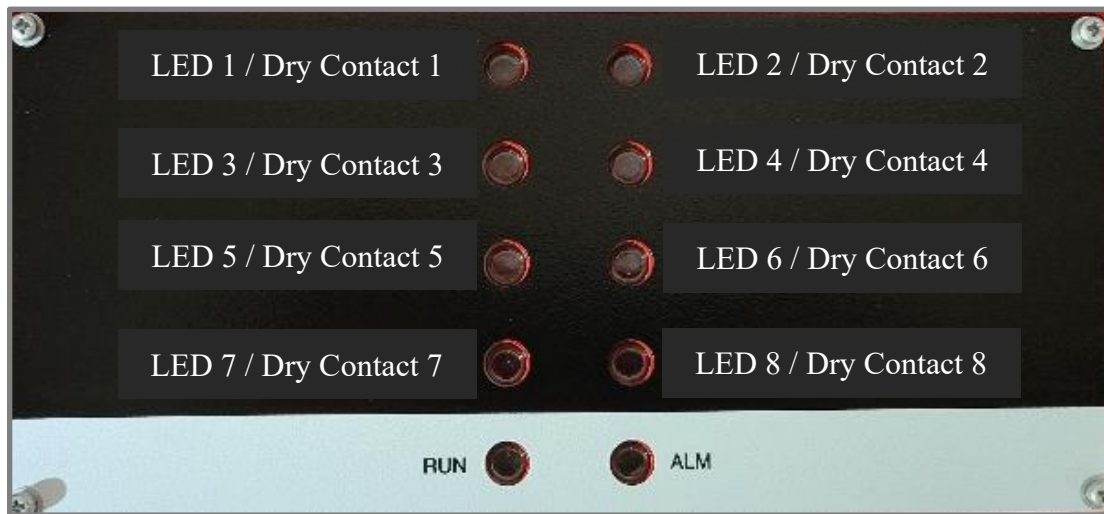

Figure 176: BDA/MU/RU LED Status Indicators

Table 25: BDA/MU/RU LED Status General Explanation

Identifier	Color	Indication
RUN	Green / Red / OFF	<b>Operation Indicator.</b> OFF = MCU cannot be powered up. Solid Red = Software is not ready / cannot boot up. Solid Green / Blinking Green = Software is normally running.
ALM	Red / OFF	<b>Alarm Indicator.</b> OFF = No Alarm. Solid RED = Dry Contact Alarms. Red (1 blink, pause) = Any other alarms except Dry Contact Alarms.
LED / DRY1	Green / OFF	<b>Normal AC Power Indicator.</b> Green = Normal/No Alarm; OFF = NO AC Detected
LED / DRY2 - 8	Red / OFF	<b>Supervisory Alarm Indicators.</b> ON = alarm; OFF = No Alarm.

**Buzzer Control:**

The user has control over the Alarm Buzzer operation in the web GUI. This allows the user to turn OFF the buzzer during maintenance periods to avoid nuisance alarms.

Follow the below instructions to turn the buzzer ON/OFF:

**BDA:**

- Navigate to <Device – Overview – BDA Overview – Buzzer Notification - Modify>

**MU:**

- Navigate to <Home – MU Checkbox – Overview – Buzzer Notification - Modify>

**RU:**

- Navigate to <Home – RU Checkbox – Overview – Buzzer Notification - Modify>

See below Figure 177 and Table 26.

Name	Value	Actions
Summary Alarm	●	Modify
Digital Clock Lock Alarm	●	Modify
PLL Alarm	●	Modify
DT VHF ANT Disconnection Alarm	●	Modify
DT UHF ANT Disconnection Alarm	●	Modify
Over Temperature Alarm	●	Modify
Alarm Detection Duration(10s)	3	Modify
Dev Temperature	84°F (29°C)	
Over Temperature TH	176°F (80°C)	Modify
Buzzer Notification	OFF	Modify
Buzzer Silence Reset Time	24H:0M	Modify

Figure 177: V3 BDA/MU/RU Buzzer Notification GUI Control

Table 26: V3 BDA/MU/RU Alarm Buzzer Control

Buzzer Notification	Description
When Buzzer Notification = ON	<p>Any dry contact alarm(s) will trigger the buzzer. Any alarms other than dry contact alarms will NOT trigger the buzzer.</p> <p>When the physical silence switch is pushed (located inside the unit) the buzzer will mute. When the buzzer is muted, any new dry contact alarm(s) will reactivate the buzzer. When the buzzer is muted, it will automatically reactivate after “Buzzer Silence Reset Time”.</p> <p>The “Buzzer Silence Reset Time” should be set to 24 hours per code requirements. It is not recommended to adjust unless for testing purposes.</p>
When Buzzer Notification = OFF	<p>The buzzer is OFF. Dry contact or System alarms will NOT trigger the buzzer.</p>

**Buzzer Silence and LED Lamp Test Button:**

The user can silence the BDA/MU/RU Alarm Buzzer by pressing the button inside the BDA/MU/RU. The user can perform an LED Lamp Test by holding the button for longer than 5 seconds. See Figure 178 below.

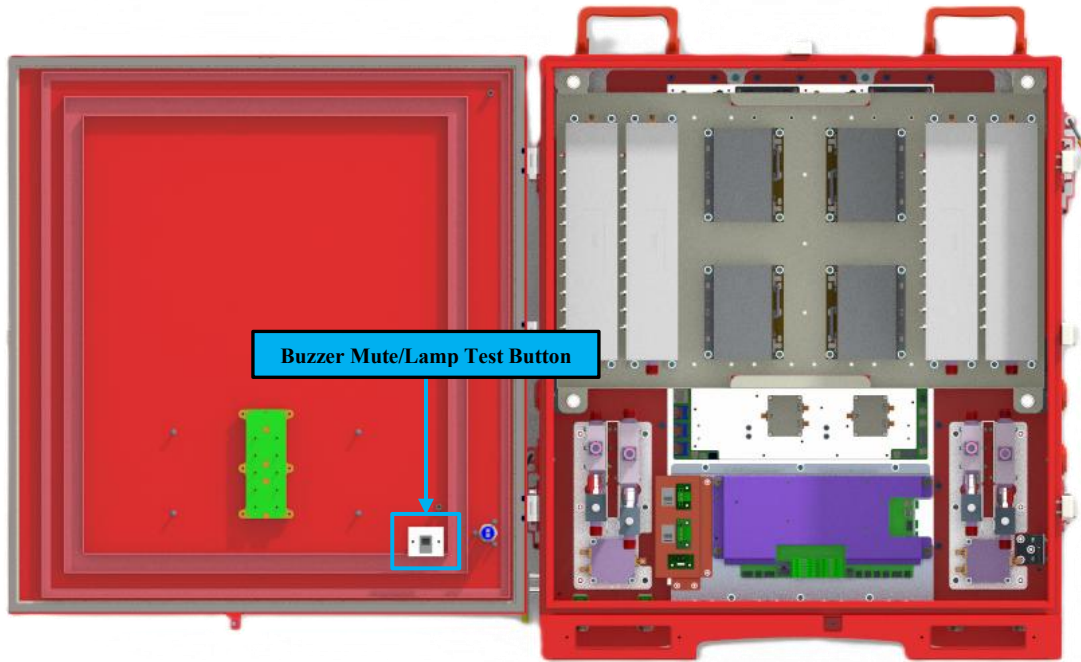

Figure 178: V3 BDA/MU/RU Alarm Buzzer Silence and LED Lamp Test Button

**Dry-Contact/LED Lamp Test through web GUI:**

The user can test the BDA/MU/RU Alarm Dry Contacts and LEDs through the web GUI.

- For BDA, navigate to <Device – Overview – External / Dry Contact ALM>. Click <Test>
- For DAS, navigate to <Home – Device Checkbox – Alarm>
- Click <Test> in top window to test all LEDs and Dry Contacts simultaneously. Click <Test> in the specific alarm row to test that alarm LED and Dry Contact.

Dry Contact Alarms		
Name	Value	Actions
Dry Contact Alarm Preset	UL2524 OCT 19 2018	Modify <b>Test</b>
Dry Contact Alarm		
Dry Contact Alarm Name	Alarm Status	Actions
AC Input normal	●	Modify <b>Test</b>
Loss of normal AC power	●	Modify <b>Test</b>
Loss of battery capacity	●	Modify <b>Test</b>
Battery charger failure	●	Modify <b>Test</b>
Active RF emitting device malfunction	●	Modify <b>Test</b>
Donor antenna malfunction	●	Modify <b>Test</b>
System component malfunction	●	Modify <b>Test</b>
Donor antenna disconnection	●	Modify <b>Test</b>

Figure 179: V3 BDA/MU/RU Dry-Contact and LED Lamp Test through the web GUI

**Alarm Detection Duration:**

The <Alarm Detection Duration> parameter allows the user to set a delay time after an alarm is detected before triggering the alarm in the GUI and Dry Contacts. A longer <Alarm Detection Duration> will allow the system to collect more samples of data and help prevent any false alarms. The value set by the user represents;  $((N \times 10) + 10)$  second delay. For example, a setting of 4 means the system will delay 50 seconds before triggering alarms and a value of 8 means a 90 second delay before triggering. The default setting is 3;  $((3 \times 10) + 10 = 40 \text{ seconds})$ .

Name	Value	Actions
Summary Alarm	●	<a href="#">Modify</a>
Digital Clock Lock Alarm	●	<a href="#">Modify</a>
PLL Alarm	●	<a href="#">Modify</a>
DT VHF ANT Disconnection Alarm	●	<a href="#">Modify</a>
DT UHF ANT Disconnection Alarm	●	<a href="#">Modify</a>
Over Temperature Alarm	●	<a href="#">Modify</a>
Alarm Detection Duration(10s)	3	<a href="#">Modify</a>
Dev Temperature	84°F (29°C)	
Over Temperature TH	176°F (80°C)	<a href="#">Modify</a>
Buzzer Notification	OFF	<a href="#">Modify</a>
Buzzer Silence Reset Time	24H.0M	<a href="#">Modify</a>

Figure 180: V3 BDA/MU/RU Alarm Detection Duration Setting

## 5.2 V2 FOU STATUS LED INDICATORS

The FOU LED indicators help the user to check the equipment's status quickly and easily. See Figure 181 and Table 27 below which explain their operation.



Figure 181: V2 FOU LED Status Indicators

Table 27: V2 FOU LED Status Indicator General Explanation

Identifier	Color	Indication
PWR	Green / OFF	OFF = No Power Detected/Power Switch OFF; ON = Device is Powered ON
RUN	Green / OFF	OFF = No Power Detected/Power Switch OFF Green (1 blink, pause) = Software is normally running.
ALM	Red / OFF	OFF = No Alarm. Solid RED = One or more alarm is active.
OP1~8	Green / OFF	OFF = Optical link is not detected Green = Optical Link is normal

### 5.3 V1 AP STATUS LED INDICATORS AND BUZZER

The V1 AP LED indicators help the user to check the equipment status quickly and easily. See Figure 182 and Table 28 below which explain their operation.

**Note: The V1 AP LEDs mirror the operation of the V3 BDA/MU/RU front panel annunciator. The V1 AP can support custom alarm configurations; however, the user must manually modify the front labelling.**



Figure 182: V1 AP LED Status Indicators

Table 28: V1 AP LED Status Indicator General Explanation

Identifier	Color	Indication
AC Input Normal	Green / OFF	<b>Normal AC Power Indicator.</b> Green = Normal/No Alarm; OFF = NO AC Detected
Loss of normal AC power DRY 1	Red / OFF	<b>Loss of normal AC Power Indicator.</b> ON = alarm; OFF = No alarm.
Loss of battery capacity DRY 2	Red / OFF	<b>Loss of battery capacity Indicator.</b> ON = alarm; OFF = No alarm.
Battery charger failure DRY 3	Red / OFF	<b>Battery charger failure Indicator.</b> ON = alarm; OFF = No alarm.
Donor antenna disconnection DRY 4	Red / OFF	<b>Donor antenna disconnection Indicator.</b> ON = alarm; OFF = No alarm.
Active RF-emitting device malfunction DRY 5	Red / OFF	<b>Active RF-emitting device malfunction Indicator.</b> ON = alarm; OFF = No alarm.
System component malfunction / DRY 6	Red / OFF	<b>System component malfunction Indicator.</b> ON = alarm; OFF = No alarm.
Donor antenna malfunction DRY 7	Red / OFF	<b>Donor Antenna Malfunction Indicator.</b> ON = alarm; OFF = No alarm.
Panel Comm. Fault DRY 8	Red / OFF	<b>Panel Comm. Fault Indicator.</b> ON = alarm; OFF = No alarm
Panel Normal	Green / OFF	ON = Panel normal; OFF = Panel fault

The V1 AP annunciator is designed to display alarms according to the UL2524 2<sup>nd</sup> Rev Oct 2018 standard. To match the alarms of the V3 BDA/MU/RU Annunciator to the V1 AP, you must select the "UL2524 Oct 19, 2018" option in the GUI. If you would like to use a different alarm configuration for the V1 AP, you must manually install new labels over the factory installed label and update the software GUI accordingly.

- Login to the Web GUI and click on Device -> Overview -> External/Dry Contact ALM.
- Click "Modify" to update the Dry Contact Alarm preset to "UL2524 OCT 19 2018".

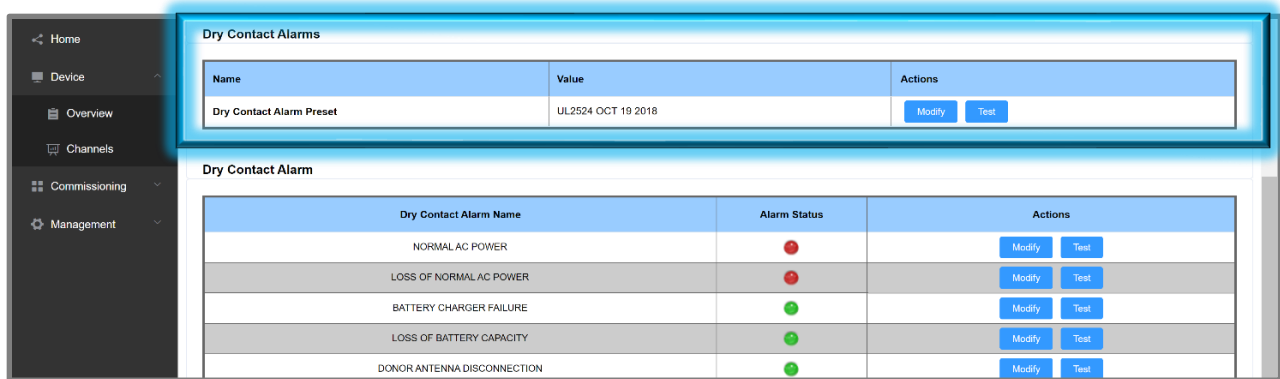

Figure 183: V1 AP Alarm Matching Setting in V3 BDA/MU/RU WEB GUI

### 5.4 V3 AP STATUS LED INDICATORS, BUZZER, AND LAMP TEST

The V3 AP LED indicators help the user to check the equipment/system status quickly and easily. See below Figure 184 and 185 as well as Table 29 and 30 which explain their operation.



Figure 184: V3 AP LED Status Indicators

Table 29: V3 AP LED Status Indicator General Explanation

Identifier	Color	Indication
LED 1 / BDA Dry Contact 1	Green/Red	Green=Normal; Red=Alarm (AC Power Alarm)
LED 2 / BDA Dry Contact 2	Red	Alarm indicator. ON = alarm; OFF = no alarm.
LED 3 / BDA Dry Contact 3	Red	Alarm indicator. ON = alarm; OFF = no alarm.
LED 4 / BDA Dry Contact 4	Red	Alarm indicator. ON = alarm; OFF = no alarm.
LED 5 / BDA Dry Contact 5	Red	Alarm indicator. ON = alarm; OFF = no alarm.
LED 6 / BDA Dry Contact 6	Red	Alarm indicator. ON = alarm; OFF = no alarm.
LED 7 / BDA Dry Contact 7	Red	Alarm indicator. ON = alarm; OFF = no alarm.
LED 8 / BDA Dry Contact 8	Red	Alarm indicator. ON = alarm; OFF = no alarm.
RUN	Red	Operation indicator. 1. OFF: MCU cannot be powered up 2. Solid RED: Software is not ready / cannot boot up 3. Solid Green: Software is running normally
ALM	Red	Alarm indicator. ON = alarm; OFF = no alarm. 1. OFF: No Alarm 2. Solid Red: Dry Contact 1-8 active 3. Red (1 blink, pause): Any other alarms besides Dry Contact configured alarms.
FOU1~FOU4	Green	Indicates that the alarm display panel displays alarms for a specific FOU. *For APV3-DAS only
Lamp Test	N/A	Insert Key and rotate 90 degrees clockwise. Hold the Lamp Test button to perform a lamp self-check.
Silence	N/A	Insert Key and rotate 90 degrees clockwise. Press the Silence button to silence the buzzer.



Figure 185: V3 AP Default LED Alarm Configuration UL2524 2018 2<sup>nd</sup> Revision

Table 30: V3 AP Default LED Alarm Configuration UL2524 2018 2<sup>nd</sup> Revision

Identifier	Color	Indication
AC Input normal	Green/Red	When AC input is ok, GREEN. RED if in alarm.
Loss of normal AC power	Red	When AC input is not present, ON
Loss of battery capacity	Red	When battery voltage is lower than the threshold, ON
Battery charger failure	Red	When AC/DC module detects fault, ON
Active RF emitting device malfunction	Red	When the Public safety product generates Booster failure alarm event, ON
Donor antenna disconnection	Red	When the Public safety product generates Donor Antenna Disconnection alarm, ON
System component malfunction	Red	When the Public safety product generates System Component alarm, ON
Donor antenna malfunction	Red	When the Public safety product generates Donor Antenna malfunction alarm, ON
Panel Comm. Fault	Red	When the communication between Alarm panel and BBU unit is abnormal, ON
Panel Normal	Green	When Alarm panel works normally, ON
FOU1~FOU4	Green	Indicates that the alarm display panel displays alarms for a specific FOU. When FOU detected, ON <i>*For APV3-DAS only</i>
Lamp Test	N/A	Insert Key and rotate 90 degrees clockwise. Hold the Lamp Test button to perform a lamp self-check.
Silence	N/A	Insert Key and rotate 90 degrees clockwise. Press the Silence button to silence the buzzer.

### 5.5 ALARM INDICATORS IN THE WEB GUI

There are several pages of the user GUI that contain alarm status indicators and/or alarm configuration parameters. See Tables 31 and 32 below which describe where the alarm status indicators and configuration parameters can be found in the V3 BDA/MU/RU devices

Table 31: V3 BDA - Web GUI Alarm Configuration and Status

Parameter name/location	Description
Dashboard	View of all dry contact alarm status. View of all current system alarms.
Device – Overview– BDA Overview	General device alarm status. VHF/UHF band specific alarm status
Device – Overview– External/Dry Contact ALM	External Alarms and Dry Contact Alarms
Device – Overview– Internal Charger Status	Power Supply and Battery Charger status and alarms.
Device – Overview – External Annunciator Panel	Comba External Annunciator Panel status and alarms.
Device – Overview – Advanced Settings	Settings for Oscillation Alarm and Antenna Disconnection Alarm.

Table 32: V3 Fiber DAS – Web GUI Alarm Configuration and Status

Parameter name	Description
Home page	View of all dry contact alarm status. View of all current system alarms.
Home – Device Checkbox - Overview	General device alarm status. 700MH/800MHz band specific alarm status
Home – Device Checkbox – Alarm	External Alarms and Dry Contact Alarms
Home – Device Checkbox – BBU	Power Supply and Battery Charger status and alarms.
Home – Device Checkbox – AP	Comba External Annunciator Panel status and alarms.
Home – Device Checkbox – Advanced	Settings for Oscillation Alarm and Antenna Disconnection Alarm.

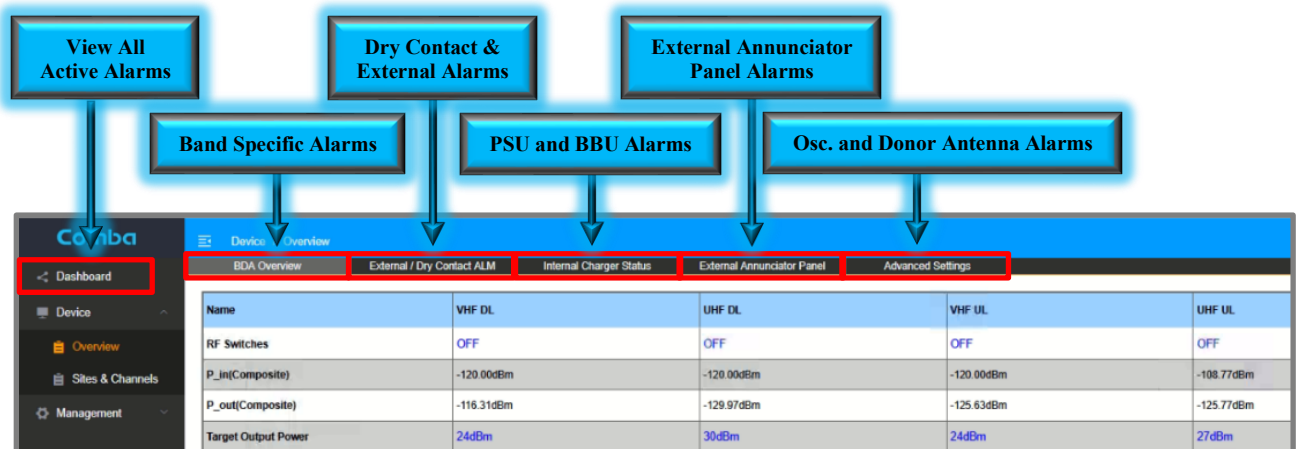

Figure 186: V3 BDA/MU/RU – Web GUI Alarm Configuration and Status

Table 33 contains a complete list of all internal device alarms. Each of these individual alarms can be configured to trigger one of the 8 Dry Contact outputs. By default, the V3 BDA/MU/RU devices will use the NFPA 1221 2019 alarm configuration, and the internal alarms are already configured for that standard. The user can choose one of the standard presets, or they can use a custom user defined configuration and configure which internal system alarms are mapped to each Dry Contact Output relay.

Table 33: V3 BDA/MU/RU - Complete List of Device Alarms

Summary Alarm	Dry Contact Alarm	Individual System Alarms	Related Bands / Modules / Devices
Yes	Configurable	DL P_in Low Alarm	DL VHF, DL UHF
Yes	Configurable	DL P_out Low Alarm	DL VHF, DL UHF
Yes	Configurable	DL P_in Over Alarm	DL VHF, DL UHF
Yes	Configurable	DL P_out Over Alarm	DL VHF, DL UHF
Yes	Configurable	LNA Alarm	DL VHF, DL UHF, UL VHF, UL UHF
Yes	Configurable	PA Alarm	DL VHF, DL UHF, UL VHF, UL UHF
Yes	Configurable	PA Shutdown Alarm	DL VHF, DL UHF, UL VHF, UL UHF
Yes	Configurable	VSWR Alarm	DL VHF, DL UHF
Yes	Configurable	Oscillation Shutdown Alarm	VHF, UHF, hidden when the feature is OFF
Yes	Configurable	Oscillation Gain Reduction Alarm	VHF, UHF, hidden when the feature is OFF
Yes	Configurable	Digital Clock Lock Alarm	Device
Yes	Configurable	PLL Alarm	Device
Yes	Configurable	DT ANT Disconnection Alarm	Device
Yes	Configurable	Over Temperature Alarm	Device
Yes	Configurable	External Alarms 1-4	Device
Yes	Configurable	External Alarm 5	Device / Preconfigured as Door Open Alarm
Yes	Configurable	Loss Of Normal AC Power	BBU, hidden when not using BBU V3
Yes	Configurable	Battery Low Alarm	BBU, hidden when not using BBU V3
Yes	Configurable	Charger Fault Alarm	BBU, hidden when not using BBU V3
Yes	Configurable	Battery Over-Discharge Alarm	BBU, hidden when not using BBU V3
Yes	Configurable	Battery Over Temperature Alarm	BBU, hidden when not using BBU V3
Yes	Configurable	Battery Connection Fail Alarm	BBU, hidden when not using BBU V3
Yes	Configurable	Battery Comm. Fault Alarm	BBU, hidden when not using BBU V3
Yes	Configurable	Charger Comm. Fault Alarm	BBU, hidden when not using BBU V3
Yes	Configurable	System Dry ALM 1	RU Dry Contact 1 Alarm
Yes	Configurable	System Dry ALM 2	RU Dry Contact 2 Alarm
Yes	Configurable	System Dry ALM 3	RU Dry Contact 3 Alarm

Yes	Configurable	System Dry ALM 4	RU Dry Contact 4 Alarm
Yes	Configurable	System Dry ALM 5	RU Dry Contact 5 Alarm
Yes	Configurable	System Dry ALM 6	RU Dry Contact 6 Alarm
Yes	Configurable	System Dry ALM 7	RU Dry Contact 7 Alarm
Yes	Configurable	System Dry ALM 8	RU Dry Contact 8 Alarm
Yes	Configurable	System OP RX Alarm	FOU to RU Optical Alarm
Yes	Configurable	System OP TX Alarm	FOU to RU Optical Alarm
Yes	Configurable	FOU 1 Comm. Fault Alarm	MU to FOU1 Comm Fault
Yes	Configurable	FOU 2 Comm. Fault Alarm	MU to FOU2 Comm Fault
Yes	Configurable	FOU 3 Comm. Fault Alarm	MU to FOU3 Comm Fault
Yes	Configurable	FOU 4 Comm. Fault Alarm	MU to FOU4 Comm Fault
Yes	Configurable	AP 1 Comm. Fault Alarm	Comba AP 1, hidden when no AP is connected
Yes	Configurable	AP 2 Comm. Fault Alarm	Comba AP 2, hidden when no AP is connected
Yes	Configurable	AP 3 Comm. Fault Alarm	Comba AP 3, hidden when no AP is connected
Yes	Configurable	AP 4 Comm. Fault Alarm	Comba AP 4, hidden when no AP is connected

**Relationships between different alarms:**

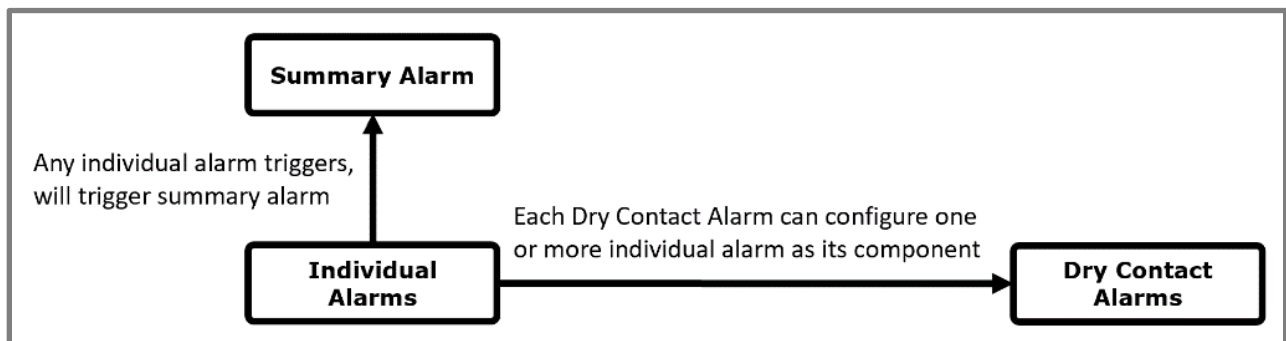

Figure 187: Alarms – Relationship between Individual, Dry Contact, and Summary Alarms

## 5.6 DRY-CONTACT AND EXTERNAL ALARM WIRING

### Dry Contact Alarms:

The V3 BDA/MU and RU have 8 dry contact outputs, each one supports either Normally Open or Normally Closed operation. The user can configure each of the 8 dry-contact alarm outputs through the software GUI. There are default alarm configurations in the software GUI that match the annunciator front plates that are included with the unit. Furthermore, for non-standard/custom alarm configurations, the user can select which internal device alarms will trigger each dry-contact alarm output. In the Fiber DAS configuration, RU alarms are also mirrored and generated at the BDA/MU Dry Contacts such that the entire system of alarms can be summarized at the BDA/MU. EOL (End-of-Line) Resistors can be installed across the Dry Contact Alarm terminals. The Phoenix Alarm Connectors are removable for ease of wire installation.

Table 34: V3 BDA/MU/RU Dry Contact Ratings

Dry Contact Ratings
Current: 1A
Voltage: 30VDC

### External Alarms:

The V3 BDA/MU/RU has 5 external alarm inputs which can accept dry contact outputs from external devices. These external alarm contacts carry 5VDC and the polarity is indicated by the “+” and “-” marks on the terminals. The external alarms can be setup in the software GUI to trigger from a Normally Open or Normally Closed device trigger. Furthermore, the external alarm inputs can be configured to trigger one or more of the dry-contact alarm outputs. Additionally, any of the external alarm inputs can be configured to control the RF and shut down the RF amplifiers through the software. This allows for a quick RF Shut Down by a simple push of a button (Example EPO Switch). The External Alarm 5 is pre-configured from the factory as the “Door Open Alarm”. If the user does not wish to use the Door Open Alarm or requires the External Alarm 5 for a different device, the Door Alarm wires must be removed. Please ensure the device is completely powered down before making this wire connection. Install the new device wires in External Alarm 5 and reconfigure accordingly in the software GUI.

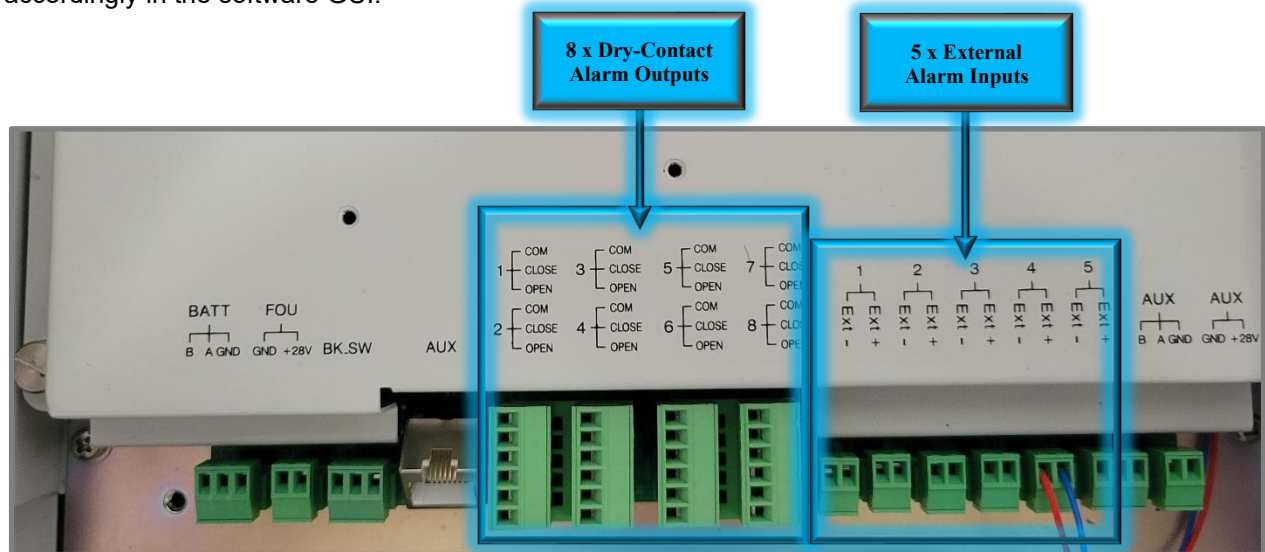

Figure 188: V3 BDA/MU/RU Dry-Contact Output and External Input Alarms Connection

See Figure 189 below for a typical supervisory alarm connection from the BDA/MU/RU to a Fire Alarm Panel. The example below shows the BDA/MU feeding 7 alarms to the fire alarm panel per the UL2524 2<sup>nd</sup> Rev 2018 standard. This is a common configuration, and Comba provides a setting in the software GUI to easily configure these alarms. Also, as described in the General Information section, Comba provides several different front-panel annunciator plates with BDA/MU/RU to match the specific alarm configuration required by your authority. See section 2.17 for instructions on how to install/replace the annunciator front plate.

**Note:** In the Fiber DAS configuration, RU alarms are also mirrored and generated at the BDA/MU Dry Contacts such that the entire system of alarms can be summarized at the BDA/MU.

**Example:** If a RU has a “Loss of Normal AC Power” Alarm, the Dry Contact #1 alarm will be triggered at both the RU and BDA/MU.

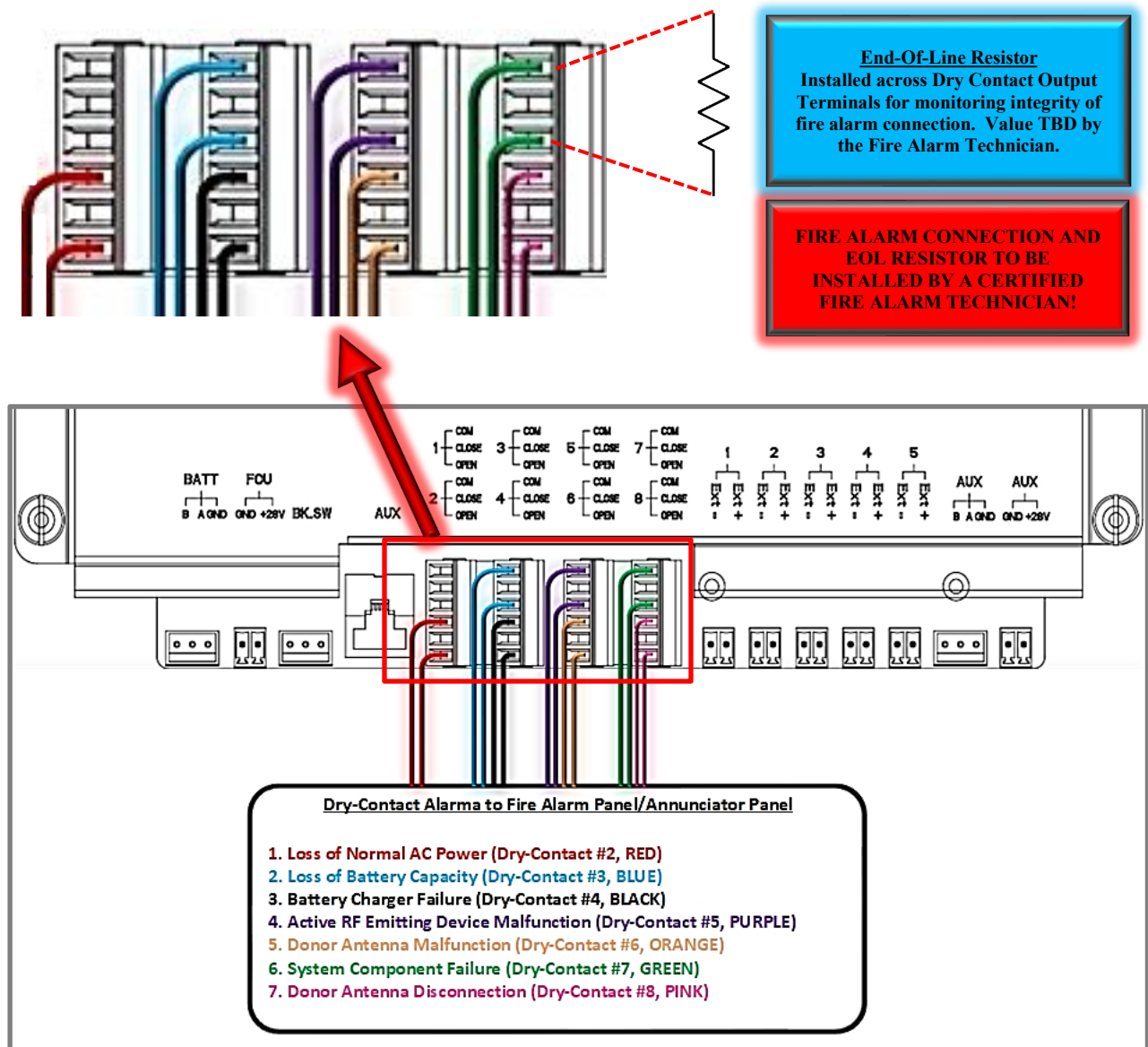

Figure 189: V3 BDA/MU/RU NO Dry-Contact Alarm Wiring Example – UL2524 2<sup>nd</sup> Rev Oct 2018

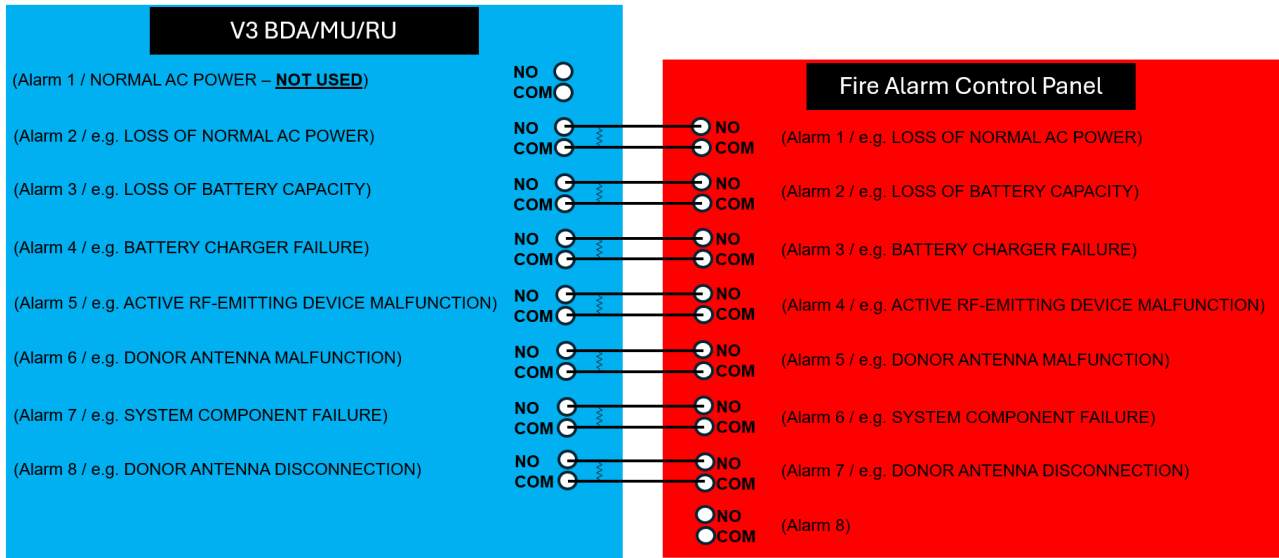

Figure 190: V3 BDA/MU/RU Normally Open Dry-Contact Wiring Diagram Example

## 5.7 DRY-CONTACT AND EXTERNAL ALARM SETTINGS

The user can easily configure the Dry Contact and External Alarms from the web GUI. The user can select a default alarm preset or they can create a custom user-defined configuration. See Figure 191 below.

**Note: The V3 APs DO NOT have any Dry Contact Outputs. However, their LEDs mirror the Dry Contact Alarm configuration.**

- Navigate to <Device – Overview - External/Dry Contact ALM>

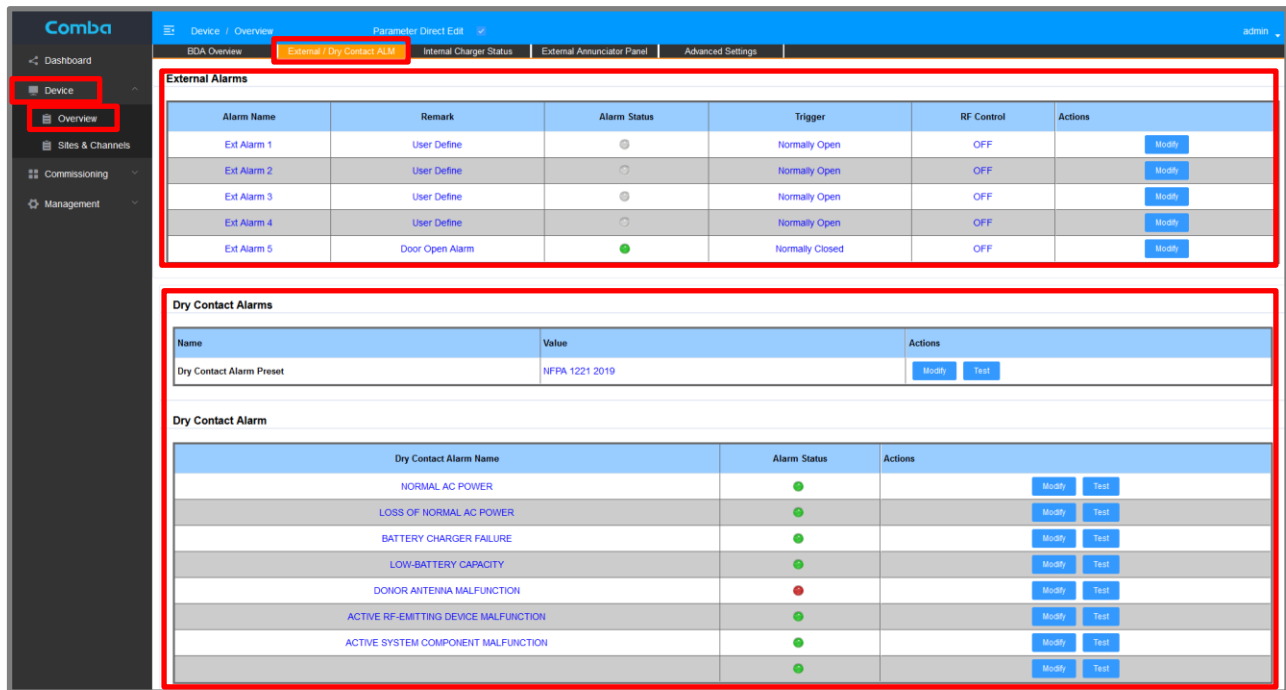

Figure 191: V3 BDA/MU/RU - Dry Contact and External Alarm Setup through web GUI

There are multiple alarm preset options in the BDA/MU/RU web GUI so the user can easily configure alarms for the local jurisdiction code requirements. The BDA/MU/RU and AP have replaceable alarm indicator plates that match the software alarm presets. These alarm plates are included in the device accessory kits. Furthermore, the user can define their own set of custom alarms for each Dry Contact Output. Refer to Table 35 below describing the available alarm presets.

Table 35: V3 BDA/MU/RU - Dry Contact and LED Alarm Presets

Dry Contact/AP LED Alarm Preset	Description
<b>UL2524 Oct 2018</b>	Dry Contacts and AP LEDs to meet UL2524 2 <sup>nd</sup> Revision standard
<b>NFPA 1221 2019 (DEFAULT)</b>	Dry Contacts and AP LEDs to meet NFPA 1221 2019 standard
<b>NFPA 1225 2022</b>	Dry Contacts and AP LEDs to meet NFPA 1225 2022 standard
<b>IFC 510 2021</b>	Dry Contacts and AP LEDs to meet IFC 510 2021 standard
<b>User Defined</b>	Custom configuration for custom alarm requirements. User can set the specific internal device alarms for each Dry Contact

Dry contact alarms 1 through 8 and AP LED's 1 through 8 are configured according to these standard presets and the APs will display the alarms accordingly. See Tables 36 through 39 below that describe each Dry Contact/AP LED preset configuration and the associated internal system alarms that are configured to trigger them.

Table 36: NFPA 1221 2019 Alarm Preset Dry Contact and LED Operation

LED/Dry Contact	NFPA 1221 2019	Default Alarm Configuration
1	<b>NORMAL AC POWER</b>	AC Normal System Dry ALM 1
2	<b>LOSS OF NORMAL AC POWER</b>	AC Lost Alarm System Dry ALM 2
3	<b>BATTERY CHARGER FAILURE</b>	Charger Fault Alarm Charger Comm. Fault Alarm System Dry ALM 3
4	<b>LOW-BATTERY CAPACITY</b>	Battery Low Alarm Battery Connection Fail Alarm Battery Over Temperature Alarm Battery Comm. Fault Alarm Battery Over Discharge Alarm System Dry ALM 4
5	<b>DONOR ANTENNA MALFUNCTION</b>	DT ANT Disconnection Alarm System Dry ALM 5
6	<b>ACTIVE RF-EMITTING DEVICE MALFUNCTION</b>	PA Alarm VHF/UHF DL/UL DL P_in Over Alarm VHF/UHF DL DL P_out Over Alarm VHF/UHF DL LNA Alarm VHF/UHF DL/UL Oscillation Shutdown Alarm Oscillation Gain Reduction Alarm PLL Alarm Digital Clock Alarm VSWR Alarm DL VHF/UHF Over Temperature Alarm System OP TX Alarm System OP RX Alarm FOU Comm. Fault Alarm (FOU1~4) System Dry ALM 6
7	<b>ACTIVE SYSTEM COMPONENT MALFUNCTION</b>	Same as "ACTIVE RF-EMITTING DEVICE MALFUNCTION" System Dry ALM 7
8	<b>Blank</b>	Blank

Table 37: UL2524 Oct 2018 Alarm Preset Dry Contact and LED Operation

LED/Dry Contact	UL2524 OCT 2018	Default Alarm Configuration
1	<b>AC Input Normal</b>	AC Normal System Dry ALM 1
2	<b>Loss of normal AC power</b>	AC Lost Alarm System Dry ALM 2
3	<b>Loss of battery capacity</b>	Battery Low Alarm Battery Connection Fail Alarm Battery Over Temperature Alarm Battery Comm. Fault Alarm Battery Over Discharge Alarm System Dry ALM 3
4	<b>Battery charger failure</b>	Charger Fault Alarm Charger Comm. Fault Alarm System Dry ALM 4
5	<b>Active RF-emitting device malfunction</b>	PA Alarm VHF/UHF DL/UL DL P_in Over Alarm VHF/UHF DL DL P_out Over Alarm VHF/UHF DL LNA Alarm VHF/UHF DL/UL Oscillation Shutdown Alarm Oscillation Gain Reduction Alarm PLL Alarm Digital Clock Alarm VSWR Alarm DL VHF/UHF Over Temperature Alarm System OP TX Alarm System OP RX Alarm FOU Comm. Fault Alarm (FOU1~4) System Dry ALM 5
6	<b>Donor antenna malfunction</b>	DT ANT Disconnection Alarm System Dry ALM 6
7	<b>System component malfunction</b>	Same as "Active RF-emitting device malfunction" System Dry ALM 7
8	<b>Donor antenna disconnection</b>	DT ANT Disconnection Alarm System Dry ALM 8

Table 38: NFPA 1225 2022 Alarm Preset Dry Contact and LED Operation

LED/Dry Contact	NFPA 1225 2022	Default Alarm Configuration
1	<b>NORMAL AC POWER</b>	AC Normal System Dry ALM 1
2	<b>LOSS OF NORMAL AC POWER</b>	AC Lost Alarm System Dry ALM 2
3	<b>BATTERY-CHARGER FAILURE</b>	Charger Fault Alarm Charger Comm. Fault Alarm System Dry ALM 3
4	<b>LOW-BATTERY CAPACITY</b>	Battery Low Alarm Battery Connection Fail Alarm Battery Over Temperature Alarm Battery Comm. Fault Alarm Battery Over Discharge Alarm System Dry ALM 4
5	<b>SIGNAL SOURCE MALFUNCTION</b>	DT ANT Disconnection Alarm System Dry ALM 5
6	<b>ACTIVE RF-EMITTING DEVICE MALFUNCTION</b>	PA Alarm VHF/UHF DL/UL DL P_in Over Alarm VHF/UHF DL DL P_out Over Alarm VHF/UHF DL LNA Alarm VHF/UHF DL/UL Oscillation Shutdown Alarm Oscillation Gain Reduction Alarm PLL Alarm Digital Clock Alarm VSWR Alarm DL VHF/UHF Over Temperature Alarm System OP TX Alarm System OP RX Alarm FOU Comm. Fault Alarm (FOU1~4) System Dry ALM 6
7	<b>ACTIVE SYSTEM COMPONENT MALFUNCTION</b>	Same as "ACTIVE RF-EMITTING DEVICE MALFUNCTION" System Dry ALM 7
8	<b>Blank</b>	Blank

Table 39: IFC 510 2021 Alarm Preset Dry Contact and LED Operation

LED/Dry Contact	IFC 510 2021	Default Alarm Configuration
1	<b>LOSS OF NORMAL AC POWER SUPPLY</b>	AC Lost Alarm System Dry ALM 1
2	<b>SYSTEM BATTERY CHARGER(S) FAILURE</b>	Charger Fault Alarm Charger Comm. Fault Alarm System Dry ALM 2
3	<b>MALFUNCTION OF THE DONOR ANTENNA(S)</b>	DT ANT Disconnection Alarm System Dry ALM 3
4	<b>FAILURE OF ACTIVE RF-EMITTING DEVICE(S)</b>	PA Alarm VHF/UHF DL/UL DL P_in Over Alarm VHF/UHF DL DL P_out Over Alarm VHF/UHF DL LNA Alarm VHF/UHF DL/UL Oscillation Shutdown Alarm Oscillation Gain Reduction Alarm PLL Alarm Digital Clock Alarm VSWR Alarm DL VHF/UHF Over Temperature Alarm System OP TX Alarm System OP RX Alarm FOU Comm. Fault Alarm (FOU1~4) System Dry ALM 4
5	<b>LOW-BATTERY CAPACITY AT 70% REDUCTION OF OPERATING CAPACITY</b>	Battery Low Alarm Battery Connection Fail Alarm Battery Over Temperature Alarm Battery Comm. Fault Alarm Battery Over Discharge Alarm System Dry ALM 5
6	<b>FAILURE OF CRITICAL SYSTEM COMPONENTS</b>	Same as "FAILURE OF ACTIVE RF-EMITTING DEVICE(S)" System Dry ALM 6
7	<b>ERRCS ANNUNCIATOR PANEL COMMUNICATION ALARM</b>	AP Comm. Fault Alarm (AP1~4) System Dry ALM 7
8	<b>OSCILLATION OF ACTIVE RF-EMITTING DEVICE</b>	Oscillation Shutdown Alarm Oscillation Gain Reduction Alarm System Dry ALM 8

## 5.8 USER DEFINED DRY CONTACT AND LED ALARM CONFIGURATION

In some cases, the user may require an alarm configuration that is not consistent with one of the available alarm presets. For the user to customize Dry Contact and LED alarm operation, they must access the web GUI and choose the “User Defined” option in the device Dry Contact preset dropdown. Once this option has been selected, the user can change the Dry Contact alarm name and configurations from the settings table. Each Dry Contact alarm can now be custom named and configured to trigger upon any system alarm the user chooses.

Figures 192 and 193 below are examples of how to configure a “User Defined” alarm option.

- In the BDA/MU/RU, navigate to <Device – Overview - External/Dry Contact ALM> and click on <Modify> in the Dry Contact Alarm Preset row.
- Change a specific alarm name by clicking on the blue text in the Dry Contact Alarm row.
- Click on <Modify> in an alarm row to select which internal system alarms will activate the alarm.

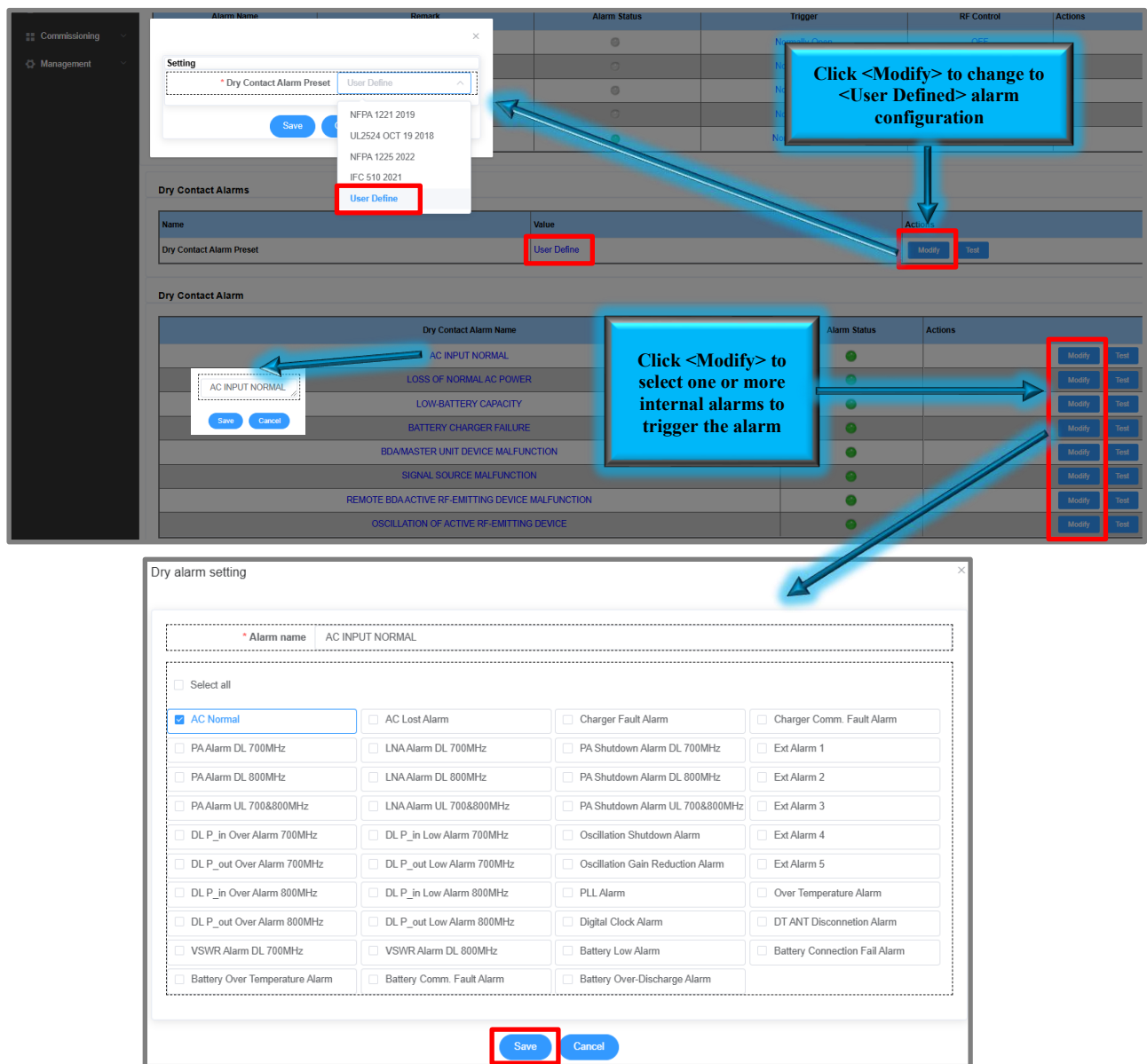

Figure 192: V3 BDA/MU/RU - User Defined Dry Contact Alarm Setup

## 5.9 EXTERNAL ALARMS

In some cases, the user may require incorporating external device alarms into the DAS solution and have them monitored at the FACP and displayed on the AP. Examples would include a third-party bias-T system required to monitor a donor antenna or an External Temperature Sensor to monitor the room temperature. These third-party device alarm outputs can be connected to an external alarm input of the BDA/MU/RU device for the purpose of monitoring and sending out an alarm. Once an external input is enabled in the web GUI, configure the alarm on the Dry Contacts and AP LEDs by activating the external alarm within the Dry Contact. Figure 193 below is an example of how to configure the Dry Contact you wish to map the External Alarm.

- Navigate to Device → Overview → External/Dry Contact ALM

The screenshot displays the 'External Alarms' configuration page in the Comba web GUI. It is divided into three main sections:

**External Alarms Table:**

Alarm Name	Remark	Alarm Status	Trigger	RF Control	Actions
Ext Alarm 1	User Define	●	Normally Open	OFF	Modify
Ext Alarm 2	User Define	○	Normally Open	OFF	Modify
Ext Alarm 3	User Define	●	Normally Open	OFF	Modify
Ext Alarm 4	User Define	○	Normally Open	OFF	Modify
Ext Alarm 5	Door Open Alarm	●	Normally Closed	OFF	Modify

**Dry Contact Alarm Name Table:**

Dry Contact Alarm Name	Alarm Status	Actions
NORMAL AC POWER	●	Modify Test
LOSS OF NORMAL AC POWER	●	Modify Test
BATTERY CHARGER FAILURE	●	Modify Test
LOW-BATTERY CAPACITY	●	Modify Test
DONOR ANTENNA MALFUNCTION	●	Modify Test
ACTIVE RF-EMITTING DEVICE MALFUNCTION	●	Modify Test
ACTIVE SYSTEM COMPONENT MALFUNCTION	●	Modify Test

**External Alarm Configuration (NORMAL AC POWER):**

Alarm name: NORMAL AC POWER

Select all:

AC Normal

Other alarm options include: AC Lost Alarm, Charger Fault Alarm, Charger Comm. Fault Alarm, PA Alarm DL 700MHz, LNA Alarm DL 700MHz, PA Shutdown Alarm DL 700MHz, Ext Alarm 1, PA Alarm DL 800MHz, LNA Alarm DL 800MHz, PA Shutdown Alarm DL 800MHz, Ext Alarm 2, PA Alarm UL 700&800MHz, LNA Alarm UL 700&800MHz, PA Shutdown Alarm UL 700&800MHz, Ext Alarm 3, DL P\_in Over Alarm 700MHz, DL P\_in Low Alarm 700MHz, Oscillation Shutdown Alarm, Ext Alarm 4, DL P\_out Over Alarm 700MHz, DL P\_out Low Alarm 700MHz, Oscillation Gain Reduction Alarm, Ext Alarm 5, DL P\_in Over Alarm 800MHz, DL P\_in Low Alarm 800MHz, PLL Alarm, Over Temperature Alarm, DL P\_out Over Alarm 800MHz, DL P\_out Low Alarm 800MHz, Digital Clock Alarm, DT ANT Disconnection Alarm, VSWR Alarm DL 700MHz, VSWR Alarm DL 800MHz, Battery Low Alarm, Battery Connection Fail Alarm, Battery Over Temperature Alarm, Battery Comm. Fault Alarm, Battery Over-Discharge Alarm.

Figure 193: V3 BDA/MU/RU - External Alarm Settings

## 5.10 V3 AP SILENCE AND LAMP TEST

The V3 AP models have both a Silence button and a Lamp Test button. The Silence button can be used to mute the buzzer after an alarm is activated. After a user defined period, the alarm buzzer will sound again. Furthermore, if a new alarm becomes active after the Silence button has been pushed, the buzzer will sound to indicate a new alarm is present. The Lamp Test button is used to test all the LEDs on the annunciator front panel. Since most of the time these LEDs remain off, a Lamp Test can check that all LEDs are still working as intended. To Silence an alarm or perform a Lamp Test, you must first activate the Key Switch with the key that is provided in the accessory kit. Refer to Figure 194 below.

To Silence an alarm:

- Insert key into Key Switch and turn 90 degrees clockwise.
- Hold the Silence button for 1s.

To perform a Lamp Test:

- Insert key into Key Switch and turn 90 degrees clockwise.
- Hold the Lamp Test button down for 5s. All the LEDs will illuminate. Release the button and the LEDs will clear.

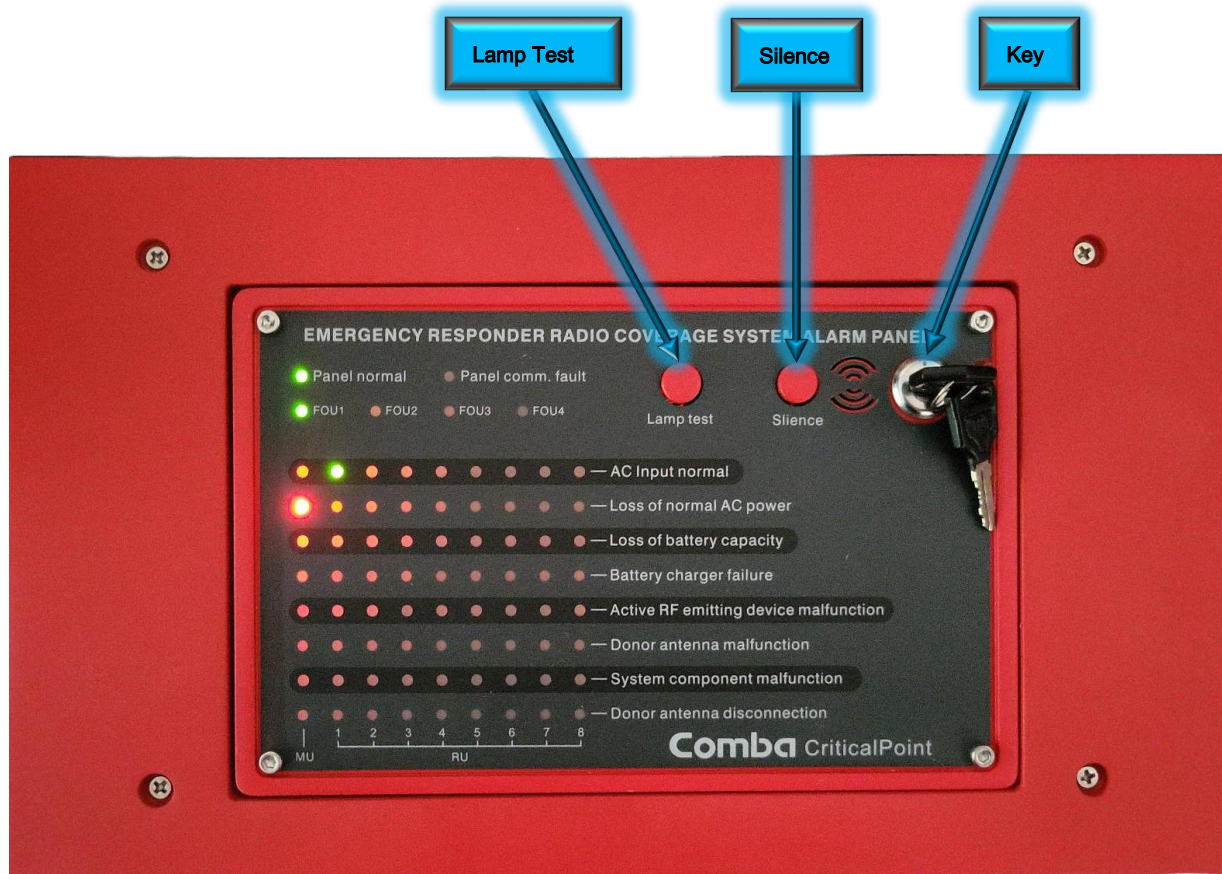

Figure 194: V3 AP - Silence Button, Lamp Test Button, and Key Switch

## 5.11 DRY-CONTACT ALARM SIMULATIONS

The V3 BDA/MU/RU Dry Contact Alarm Outputs and Front Panel LEDs can be tested through the user GUI. See section 5.1 for more details. If the user desires to create individual alarms that simulate actual alarms, they can do so following the instructions found in Table 40 and Figure 195.

Table 40: Simulating Typical Dry Contact and LED Alarms

Alarms	Simulation
Signal Booster Fail / RF-Emitting Device Fail / System Component Fail	Disconnect the service cable from the MT port to create a DL VSWR alarm
Donor Antenna Disconnection	Disconnect the donor cable from DT port
AC Lost / AC Normal	Turn off the AC switch inside the BDA/MU/RU, or turn off the AC breaker inside the BBU
Battery Charger Fail	Open the BDA/MU/RU and remove the cover of the distribution board. Unplug the Charger Communication Cable. See Figure 190 below. (This alarm will take 3-5 minutes to trigger)
Low Battery Capacity	1. Switch off the battery breaker or disconnect the DC/Battery cable from the BDA or BBU. Let the system run on battery until the battery capacity is less than the alarm threshold.  2. Navigate to <Device – Overview - Internal Charger Status> page, change "Low Capacity TH" from default value of 30% to 100% and shut off AC switch/breaker. Battery will drop to 99% within a few minutes and will trigger "Low Battery Capacity" alarm. Remember to reset the "Low Capacity TH" to 30% when done performing the test.

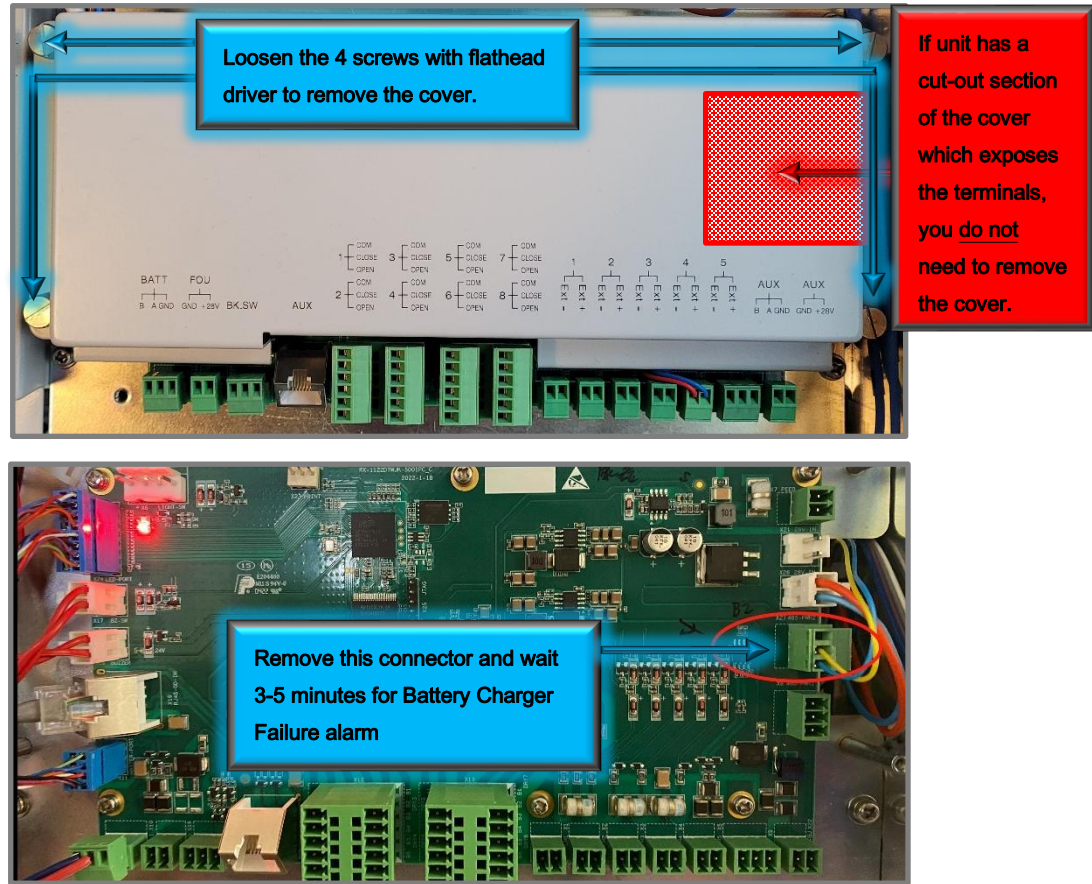

Figure 195: Simulating Battery Charger Failure

## 5.12 V3 BDA/MU/RU ALARM TROUBLESHOOTING

This section provides a guide to troubleshoot each type of individual system alarm for a BDA or Fiber DAS system. See below for a description of the cause of each alarm and the remedy to troubleshoot/fix the alarm.

<b>DL P_in Low Alarm VHF, DL P_in Low Alarm UHF</b>	
Cause	The Composite Downlink Input Power is lower than the user-defined DL P_in low threshold.
Remedy	When the Composite Downlink Input Power is higher than the user-defined DL P_in low threshold, the system will clear this alarm. Check donor antenna and cable installation.

<b>DL P_out Low Alarm VHF, DL P_out Low Alarm UHF</b>	
Cause	The Composite Downlink Output Power is lower than the user-defined DL P_out low threshold.
Remedy	When the Composite Downlink Output Power is higher than the user-defined DL P_out low threshold, the system will clear this alarm. Check donor antenna and cable installation.

<b>DL P_in Over Alarm VHF, DL P_in Over Alarm UHF</b>	
Cause	The Composite Downlink Input Power is higher than the user-defined DL P_in Over threshold.
Remedy	When the Composite Downlink Input Power is lower than the user-defined DL P_in Over threshold, the system will clear this alarm. Check DL Composite Input from the donor antenna and use DL Input ATT to reduce to >10dB below the alarm threshold.

<b>DL P_out Over Alarm VHF, DL P_out Over Alarm UHF, UL P_out Over Alarm VHF, UL P_out Over Alarm UHF</b>	
Cause	The Composite Downlink/Uplink Output Power is higher than the user-defined DL P_out Over threshold or the user-defined UL P_out Over threshold.
Remedy	When the Composite Downlink/Uplink Output Power is lower than the user-defined DL P_out Over threshold or the user-defined UL P_out Over threshold, the system will clear this alarm. If the default setting is used, the P_out Over threshold is set ABOVE the MAX Composite Power, and the alarm should only occur if the BDA AGC circuits have failed. If the user chooses to lower the threshold BELOW the MAX Composite Power, the alarm will only indicate the Output Power is above the user-defined threshold. In this case only an advisory alarm.

<b>LNA Alarm DL VHF, LNA Alarm DL UHF, LNA Alarm UL VHF, LNA Alarm UL UHF</b>	
Cause	A fault has been detected in the LNA. The LNA (Low Noise Amplifier) is located at the front-end of the RF link for both downlink and uplink paths. For the LNA status, the BDA constantly measures the current going through the LNA. When the current draw is abnormal (e.g., short or open) indicating a malfunctioned LNA, the system will trigger the alarm. A malfunctioned LNA could be caused by high input power, high reflect power, or a potential faulty LNA. The power a LNA can normally handle is < 0dBm (refer to datasheets for actual models).
Remedy	Measure the Composite Input Power to the BDA over time. If high attenuate accordingly. If a high Composite Input is not seen, and the alarm will not clear, contact Technical Support.

PA Alarm DL VHF, PA Alarm DL UHF, PA Alarm UL VHF, PA Alarm UL UHF	
Cause	<p>A fault is detected in the PA. The PA alarm is to monitor the final stage power amplifier for both downlink and uplink. The following conditions will trigger a PA alarm:</p> <ol style="list-style-type: none"> <li>1) High Temperature (Using internal threshold)</li> <li>2) High Current</li> <li>3) High Bias Voltage</li> <li>4) Overdrive (high output power), could be due to oscillation</li> <li>5) High Return Loss</li> <li>6) Other hardware issues</li> </ol> <p>When PA Protection is ON: The PA will shut down upon alarms, and reboot at 1min, 5min, 10min, 20min, 30min, and 1hour. After that, if the PA still cannot be turned on, PA will be permanently shut down.</p> <p>When PA Protection is OFF: The PA will <u>NOT</u> shut down when the above-mentioned faults are detected.</p>
Remedy	<p>Check isolation and make sure the any gain setting meets <math>&lt; (\text{isolation} - 20\text{dB})</math>, then reset PA in “tools – DL PA reset VHF or UHF / UL PA reset VHF or UHF”. If the alarm doesn’t go away, contact Technical Support.</p>

PA Shutdown Alarm DL VHF, PA Shutdown Alarm DL UHF, PA Shutdown Alarm UL VHF, PA Shutdown Alarm UL UHF	
Cause	<ol style="list-style-type: none"> <li>1) RF switches are OFF.</li> <li>2) The PA is shut down due to an internal alarm (During PA Protection, or oscillation shutdown)</li> </ol>
Remedy	<p>Turn on the RF switches. Check for PA alarms (refer to PA Alarm) and correct. Check Oscillation alarms and correct.</p>

VSWR Alarm DL VHF, VSWR Alarm DL UHF	
Cause	<p>The DL VSWR will trigger when <u>both</u> the criteria below are met:</p> <ol style="list-style-type: none"> <li>1) The VHF or UHF Downlink Composite Output power is <math>&gt; 5\text{dBm}</math>.</li> <li>2) The Return Loss is <math>&lt; 6\text{dB}</math>. Return Loss = Forward Power – Reverse Power</li> </ol>
Remedy	<p>Temporarily install a 50ohm termination load on the MT port and check if the alarm is still present. If the alarm clears, perform troubleshooting of the passive components and coaxial cables starting from the MT port. If the alarm does NOT clear with 50ohm load, contact Technical Support for further troubleshooting.</p>

<b>Oscillation Shutdown Alarm, Oscillation Gain Reduction Alarm</b>	
Cause	Oscillation has been detected in the system and action is required to restore original performance. When system detects oscillation, it will test the isolation, and set Gain according to the new isolation, if the Gain can be set to meet the new isolation number (Gain = Isolation – 20dB). Then the system will send an Oscillation Gain Reduction alarm. If the desired gain is out of the setting range, the system will shut down the PA and send an Oscillation Shutdown Alarm.
Remedy	To recover from Oscillation Gain Reduction alarm and Oscillation Shutdown Alarm, the user must evaluate the system isolation and fix the isolation issue first (refer to isolation / oscillation troubleshooting section). Then go to <Tools – tools> page and click <Oscillation Alarm Reset>. Bad isolation is possibly caused by: 1)Not enough isolation between Donor antenna and Service antenna(s). 2)Poorly installed components such as bad coaxial cable or passives which leak RF. 3)Interference by other systems – in-building commercial / neighbor units. Evaluate the RF environment on the rooftop and within the DAS coverage area to ensure no interference from adjacent/neighbor systems.

<b>Digital Clock Lock Alarm</b>	
Cause	A fault is detected in the Digital Clock Lock module. A critical Hardware issue is detected.
Remedy	Contact Technical Support.

<b>PLL Alarm</b>	
Cause	A fault is detected in the Phase-locked Loop module. A critical Hardware issue is detected.
Remedy	Contact Technical Support.

<b>DT ANT Disconnection Alarm</b>	
Cause	The BDA does not detect a DC loop between the BDA DT Port and the Donor Antenna. The DL ANT Disconnection alarm is configurable per band.
Remedy	Check Donor Antenna, Feedline, and Passive installation to ensure DC Loop path. Check to ensure Bias-T with a 50ohm Load is installed at Donor antenna.

<b>Over Temperature Alarm</b>	
Cause	When the internal device temperature is higher than the user-defined threshold. The temperature reading, and threshold can be found in the “Overview” page. The default setting is recommended. Only modify if local code requires to.
Remedy	Check the environmental temperature and the threshold setting. Correct issue.

<b>External Alarm 1-5</b>	
Cause	When an external alarm is set to Normally Open, it will trigger alarm when external source is short. When an external alarm is set to Normally Closed, it will trigger alarm when external source is open. Note: External Alarm 5 is configured for the Door Alarm from the factory.
Remedy	Check the external circuitry status by a voltage meter to confirm the alarm status. Note: this external input must be a dry contact (no voltage), otherwise it will damage the external alarm circuitry inside the BDA.
<b>System Dry ALM 1-8</b>	
Cause	A System Dry ALM has been detected from one or more Remote Units in the system. System Dry ALM's are used in the system to report Remote Unit alarms to the BDA/Master unit and trigger the corresponding Dry-Contact and LED at the BDA/Master Unit and/or connected external Annunciator Panels. The Dry-Contact configuration between the BDA/Master unit is mirrored such that an alarm at a Remote Unit will trigger at the BDA/Master unit. For example, if a Remote Unit has a "LOSS OF NORMAL AC POWER" alarm, it will trigger the System Dry ALM 1, and the BDA/Master unit will trigger it's Dry Contact output 1 indicating an AC Failure in the system.
Remedy	If APV3-DAS is installed, review the alarm status indicators to quickly identify where the alarm is being generated in the system. Log into GUI and review the <Dashboard> page for active system alarms. Identify the specific device in alarm and the specific alarm that has triggered. Correct according to the other troubleshooting guides in this section.

<b>System OP RX Alarm</b>	
Cause	The Optical Signal received by the FOU is too low. Optical Link not established.
Remedy	Check fiber installation. See Appendix K for advice on fiber installation.

<b>System OP TX Alarm</b>	
Cause	The Optical Signal transmitted from the FOU is below the internal hard-coded threshold. This indicates a failure of a hardware connection or the Optical Transceiver.
Remedy	Call Technical Support to further troubleshoot issue.

<b>FOU Comm. Fault Alarm (FOU 1 - 4)</b>	
Cause	RS485 Communication has been lost between the BDA/MU and the FOU(s). FOU and connected equipment are not detected.
Remedy	Evaluate the RS485 cable connection between the BDA/MU and the FOU devices. Inspect the FOU power connection. Ensure no cables have been damaged or disconnected. Power down equipment and replace cables if necessary. Check the cable connection between FOU's (if applicable). Unplug and reconnect cables to ensure there is a tight connection. If the problem persists, call Technical Support.

### 5.13 V3 BBU AND AP ALARM TROUBLESHOOTING

This section provides a guide to troubleshoot each type of individual system alarm for a BBU or Annunciator Panel. See below for a description of the cause of each alarm and the remedy to troubleshoot/fix the alarm.

<b>Loss Of Normal AC Power</b>	
Cause	No AC Power detected, or the AC switches are OFF.
Remedy	Check AC power source. Check AC switches in the BDA and BBU

<b>Battery Low Alarm</b>	
Cause	AC Power was lost for an extended period. The Battery capacity is lower than the threshold (normally 30%). Incorrect wiring between BDA/MU/RU and BBU.
Remedy	<ol style="list-style-type: none"> <li>1)Login to the WEB GUI to check the specific alarms that caused Battery Low Dry Contact Alarms.</li> <li>2)Check that AC Power is normal. Fix if necessary.</li> <li>3)Check Battery Low threshold and current battery capacity, in Overview – &lt;Internal Charger&gt; Tab. Adjust threshold if necessary. Default is 30% per most code requirements.</li> <li>4)Check “RUN on Battery” time and “SOC (State of Charge)”, in Overview – &lt;Internal Charger&gt; Tab. If the device is running on the Battery, this indicates a Loss of AC Power or a potential charger failure. Check AC Power source and power-cycle devices.</li> </ol> <p>If the problem persists, call Technical Support.</p>

<b>Charger Fault Alarm</b>	
Cause	The Battery Charger has a high voltage output or a high current output. The Battery Charger is in protection mode.
Remedy	Check all wire connections between the BDA/MU/RU and BBU device. Power down and fix if wire connections are incorrect. If the problem persists, call Technical Support

<b>Battery Over-Discharge Alarm</b>	
Cause	The Battery Voltage detected indicates the Battery has been over-discharged
Remedy	<ol style="list-style-type: none"> <li>1)Login to the WEB GUI to check the specific alarms that caused Battery Low Dry Contact Alarms.</li> <li>2)Check Battery Low threshold and current battery capacity, in Overview – &lt;Internal Charger&gt; Tab. Adjust threshold if necessary. Default is 30% per most code requirements.</li> <li>3)Check “RUN on Battery” time and “SOC (State of Charge)”, in Overview – &lt;Internal Charger&gt; Tab. If the device is running on the Battery, this indicates a Loss of AC Power or a potential charger failure. Check AC Power source and power-cycle devices.</li> <li>4)Check all wire connections between the BDA/MU/RU and BBU device. Power down and fix if wire connections are incorrect.</li> </ol> <p>If the problem persists, call Technical Support</p>

<b>Battery Over Temperature Alarm</b>	
Cause	The Battery Internal Temperature that is detected is high
Remedy	The room temperature is suggested to be < 35°C. If room temperature is normal, call Technical Support

<b>Battery Connection Fail Alarm</b>	
Cause	There is no Battery detected. Battery is disconnected.
Remedy	Visually check that the Battery + and – terminals as well as the RS485A and RS485B terminals are properly connected inside the BBU and the BDA/MU/RU. Ensure that the Battery is awake, with status LEDs illuminated, and the Battery breaker is ON. Power down and fix if necessary. If the connections are correct and the problem persists, call Technical Support.

<b>Battery Comm. Fault Alarm</b>	
Cause	The Battery (Battery BMS to BDA) communication has failed. The BDA/MU/RU can no longer communicate with battery. Battery parameters cannot be viewed.
Remedy	Visually check that the Battery + and – terminals as well as the RS485A and RS485B terminals are properly connected inside the BBU and the BDA/MU/RU. Ensure that the Battery is awake, with status LEDs illuminated, and the Battery breaker is ON. Power down and fix if necessary. If the connections are correct and the problem persists, call Technical Support.

<b>Charger Comm. Fault Alarm</b>	
Cause	The Battery Charger (to BDA) communication has failed. The BDA/MU/RU can no longer communicate with Battery Charger. Battery Charging parameters cannot be viewed.
Remedy	Check the communication cable connection inside the BDA/MU/RU to ensure the Battery Charger is properly connected (refer to Alarm Simulation Section). If the problem persists, call Technical Support.

<b>AP Comm. Fault Alarm (AP 1 - 4)</b>	
Cause	The AP (to BDA) communication has failed. The BDA/MU/RU cannot establish connection to the AP. The alarms will not display on the AP.
Remedy	Check the Power and RS485 connection between the BDA/MU/RU Annunciator Panel to ensure they have not been damaged or disconnected. Power down the system and correct the issue if necessary. If the problem persists, call Technical Support

Note: For additional information on troubleshooting AP communication issues, see Appendix L

## 5.14 V3 BDA AND FIBER DAS SYSTEM MAINTENANCE

The V3 System devices are designed for trouble-free operation and generally do not require maintenance unless a supervisory alarm is active. Maintenance activities should only be carried out by trained personnel. Follow your local codes for required inspections, documentation, maintenance, and repair activities.

Periodic inspection of the BDA equipment(s) is recommended, the recommended tasks include:

- Verify the direction and position of antennas. Re-align if necessary.
- Make sure the cable connector and sealing on the RF cable connectors are not damaged.
- Verify lightning and ground protection is in good condition.
- Measure the DL and UL Gain and Output Power of the BDA to ensure it has not changed and is within specifications.
- Measure the DL and UL Output Noise Power from the BDA to ensure it has not changed and is within specifications.
- Test/Simulate system alarms to ensure internal alarm mechanisms, dry-contact outputs, and status LEDs are functioning normal.
- Perform a battery load test to ensure battery is within specifications.

End of Section

## 6 APPENDICES

### 6.1 APPENDIX A: TOOLS

The following is the recommended list of tools for new installation and routine maintenance.

- Screwdrivers: Flathead and Phillips
- Pliers
- Channel Locks
- Vise Grip
- Ring Spanner (Assorted sizes)
- Level
- Tape Measure
- Power drill and drill bits
- Wire cutters
- Wire Strippers
- Craft Knife
- Anti-static Wrist Strap
- Multimeter
- RF Spectrum Analyzer (e.g. Anritsu, Signal Hound)
- Signal Generator or Tracking Generator (e.g. Signal Hound, TPI, DAStroNix, PCTEL)
- Cable and Antenna Analyzer
- N-Type RF Attenuators (Assorted values)
- N-Type RF 50ohm Termination Loads
- Various RF jumper cables and adaptors to connect between devices and test equipment
- Fiber Test Light Source
- Fiber Power Meter
- Single Mode Fiber Optic Connector Cleaner for SC/APC connectors
- Personal Protective Gear (Recommended. Follow your local codes and company safety policy for PPE. Additional PPE may be required.)
  - Hard Hat or Bump Cap
  - Protective Gloves
  - Foot Protection
  - Safety Glasses
  - Personal Fall Protection System (Installing at height)
  - Scissor Lift or Scaffolding (Installing at Height)

## 6.2 APPENDIX B: DECLARATION OF HARMFUL SUBSTANCES AND CONTENT

**Product Name: Public Safety BDA**

**Model: RX14V3**

Harmful substance and content of this product as shown in the table below:

Part Name	Harmful Substance					
	Pb	Hg	Cd	Cr (VI)	PBB	PBDE
A	×	○	○	○	○	○
B	×	○	○	○	○	○

**Note:** Above table complies with SJ/T 11364.

○: Indicates that the harmful substance content in all homogeneous materials for corresponding part is under the limited requirement of GB/T 26572.

×: Indicates that the harmful substance content in at least one single, homogeneous material for the corresponding part exceeds the limited requirement of GB/T 26572.

**Remark:** The content of the parts marked with “×” above exceeds the requirement as there is still no mature alternative technologies to achieve the replacement of poisonous and harmful materials or elements.



## 6.4 APPENDIX D: DEVICE PDF REPORT EXAMPLE

BDA Report				
<b>Device Summary</b>				
Device Info		Device Model	BDA2.0	
Serial Number	AA2280504379	System Version	RX11_A0AV01.00.01.17_5	
Carrier Mode	Class-A(High Rejection Filters)	Duplexer Model	S1	
License	800MHz,700MHz,Class A,Class B,27dBm,33dBm	Report Time	2024-05-16 12:30	
LAN Port IP/Gateway	LAN IP:192.168.5.3,Subnet Mask:255.255.255.0,Gateway IP:192.168.5.1			
<b>Device Overall Settings</b>				
Name	DL 700	UL 700	UL 800	DL 800
Frequency Bands	DL [769, 775]	UL [799, 805]	UL [806, 816]	DL [851, 861]
RF Switches	ON	ON	ON	ON
P_in(Composite)	<-90dBm	<-85dBm	<-65dBm	<-90dBm
P_out(Composite)	<0dBm	<0dBm	<0dBm	<0dBm
Target Output Power	33dBm	27dBm	27dBm	33dBm
Input ATT	0dB	0dB	0dB	0dB
Output ATT	0dB	0dB	0dB	0dB
Mute Switch	ON	ON	ON	ON
Mute TH	-90dBm	-80dBm	-80dBm	-90dBm
PA_Status	Normal	Normal	Normal	Normal
Gain Limit	90dB	65dB	65dB	90dB
P_in Low	Disabled			Disabled
P_in Low TH	-90			-90
P_out Low	Disabled			Disabled
P_out Low TH	0			0
P_in Over	Normal			Normal
P_in Over TH	-30			-30
P_out Over	Normal	Normal	Normal	Normal
P_out Over TH	39dBm	30dBm	30dBm	39dBm
LNA Alarm	Normal	Normal	Normal	Normal
PA Alarm	Normal	Normal	Normal	Normal
PA Shutdown Alarm	Disabled	Disabled	Disabled	Disabled
VSWR Alarm	Normal			Normal
Name	Value			
Summary Alarm	Normal			
Digital Clock Lock Alarm	Normal			
PLL Alarm	Normal			
DT ANT Disconnection Alarm	Disabled			
Over Temperature Alarm	Normal			
Alarm Detection Duration(10s)	5			
Buzzer Notification	ON			
Dev Temperature	77°F (25°C)			
Over Temperature TH	176°F (80°C)			
Buzzer Silence Reset Time	86400s			
Backup Alarm	Normal			
System OP RX Alarm	Normal			
System OP TX Alarm	Normal			
FOU1 Comm.Fault Alarm	Normal			
FOU2 Comm.Fault Alarm	Normal			
FOU3 Comm.Fault Alarm	Normal			
FOU4 Comm.Fault Alarm	Normal			
<b>External Alarm Setting</b>				
Alarm Name	Remark	Alarm Status	Trigger	RF Control
Ext Alarm 1	User Define	Disabled	Normally Open	OFF
Ext Alarm 2	User Define	Disabled	Normally Open	OFF
Ext Alarm 3	User Define	Disabled	Normally Open	OFF
Ext Alarm 4	User Define	Disabled	Normally Open	OFF
Ext Alarm 5	Door Open Alarm	Normal	Normally Closed	OFF

Dry Contact Alarm Settings							
Dry Contact Preset	UL2524 OCT 19 2018						
Dry Contact Alarm1	AC Input normal		normal				
AC Normal, System Dry ALM 1							
Dry Contact Alarm2	Loss of normal AC power		normal				
AC Lost Alarm, System Dry ALM 2							
Dry Contact Alarm3	Loss of battery capacity		normal				
Battery Low Alarm, Battery Connection Fail Alarm, Battery Over Temperature Alarm, Battery Comm. Fault Alarm, Battery Over-Discharge Alarm, System Dry ALM 3							
Dry Contact Alarm4	Battery charger failure		normal				
Charger Fault Alarm, Charger Comm. Fault Alarm System Dry ALM 4							
Dry Contact Alarm5	Active RF emitting device malfunction		normal				
PA Alarm DL 700MHz, LNA Alarm DL 700MHz, PA Alarm DL 800MHz, LNA Alarm DL 800MHz, PA Alarm UL 700&800MHz, LNA Alarm UL 700&800MHz, DL P_in Over Alarm 700MHz, Oscillation Shutdown Alarm, DL P_out Over Alarm 700MHz, Oscillation Gain Reduction Alarm, DL P_in Over Alarm 800MHz, PLL Alarm, Over Temperature Alarm, DL P_out Over Alarm 800MHz, Digital Clock Alarm, VSWR Alarm DL 700MHz, VSWR Alarm DL 800MHz, System Dry ALM 5, System OP RX Alarm, System OP TX Alarm, FOU1 Comm Fault Alarm, FOU2 Comm Fault Alarm, FOU3 Comm Fault Alarm, FOU4 Comm Fault Alarm							
Dry Contact Alarm6	Donor antenna malfunction		normal				
DT ANT Disconnection Alarm, System Dry ALM 6							
Dry Contact Alarm7	System component malfunction		normal				
PA Alarm DL 700MHz, LNA Alarm DL 700MHz, PA Alarm DL 800MHz, LNA Alarm DL 800MHz, PA Alarm UL 700&800MHz, LNA Alarm UL 700&800MHz, DL P_in Over Alarm 700MHz, Oscillation Shutdown Alarm, DL P_out Over Alarm 700MHz, Oscillation Gain Reduction Alarm, DL P_in Over Alarm 800MHz, PLL Alarm, Over Temperature Alarm, DL P_out Over Alarm 800MHz, Digital Clock Alarm, VSWR Alarm DL 700MHz, VSWR Alarm DL 800MHz, System Dry ALM 7, System OP RX Alarm, System OP TX Alarm, FOU1 Comm Fault Alarm, FOU2 Comm Fault Alarm, FOU3 Comm Fault Alarm, FOU4 Comm Fault Alarm							
Dry Contact Alarm8	Donor antenna disconnection		normal				
DT ANT Disconnection Alarm, System Dry ALM 8							
Internal Charger(BBU) Settings							
Battery Backup Unit	Internal	Battery Status	Full				
Low Capacity TH	30%	Time On Battery	N/A				
Cut Off TH	40V	Battery Time Remaining	N/A				
Charger Status	Normal	Battery Low Alarm	normal				
Charger Output Voltage	54.37V	Charger Fault Alarm	normal				
Load Current	1.08A	Battery Over-Discharge Alarm	normal				
Nominal Charge Capacity	30AH	Battery Over Temperature Alarm	normal				
State Of Charge(SOC)	100%	Battery Connection Fail Alarm	normal				
Battery Voltage	53.6V	Battery Comm. Fault Alarm	normal				
Charging Current	0.05A	Charger Comm. Fault Alarm	normal				
AP Settings							
AP 1 Firmware	000000000000000000	AP 2 Firmware	N/A				
AP 1 Comm. Fault Alarm	normal	AP 2 Comm. Fault Alarm	N/A				
AP 1 Dry Contact Alarm	normal	AP 2 Dry Contact Alarm	N/A				
Advanced Setting							
NetProtect Switch	OFF	PA OFF Delay	3s	PA Protection Switch	OFF		
UL Gain Limit	65dB	DL Gain Limit(700MHz)	90dB	DL Gain Limit(800MHz)	90dB		
Osc. Detection Switch		OFF					
UL Switch	N/A	DL Switch	N/A	OSC_T1(2s)	N/A		
UL_OSC_TH	N/A	DL_OSC_TH	N/A	OSC_T2(min)	N/A	OSC_T2_CycleNum	N/A
DL700M Last Isolation Mea	N/A	DL800M Last Isolation Mea	N/A				
Oscillation Shutdown(700MHz)	N/A	Oscillation Gain Reduction(700MHz)	N/A				
Oscillation Shutdown(800MHz)	N/A	Oscillation Gain Reduction(800MHz)	N/A				
DT Input Level	-97.77dBm	DT ANT Disconnection Alarm TH	-95dBm	Noise Floor TH (Isolation Test)	-95dBm		
SNMP Setting							
Communication							
Name	Value						
Version	v2c						
Trap Des: IP1	0.0.0.0						
Trap Des: IP2	0.0.0.0						
Trap Des: IP3	0.0.0.0						
Port Num	161						
Read Community	public						
Write Community	private						
SNMP Hearbeat Interval(min)	5						
SNMP Hearbeat Switch	ON						

Isolation(700Mhz)

Frequency	Noise Floor	Received Pilot Strength	Isolation	Max Gain Allowed
759.00000MHz	Not tested	Not tested	Not tested	Not tested
770.00000MHz	Not tested	Not tested	Not tested	Not tested
771.00000MHz	Not tested	Not tested	Not tested	Not tested
772.00000MHz	Not tested	Not tested	Not tested	Not tested
773.00000MHz	Not tested	Not tested	Not tested	Not tested
774.00000MHz	Not tested	Not tested	Not tested	Not tested
775.00000MHz	Not tested	Not tested	Not tested	Not tested

Frequency	Isolation	Max gain allowed	Use manual or auto
			Auto

Isolation(800Mhz)

Frequency	Noise floor	Received pilot strength	Isolation	Max gain allowed
851.00000MHz	Not tested	Not tested	Not tested	Not tested
852.00000MHz	Not tested	Not tested	Not tested	Not tested
853.00000MHz	Not tested	Not tested	Not tested	Not tested
854.00000MHz	Not tested	Not tested	Not tested	Not tested
855.00000MHz	Not tested	Not tested	Not tested	Not tested
856.00000MHz	Not tested	Not tested	Not tested	Not tested
857.00000MHz	Not tested	Not tested	Not tested	Not tested
858.00000MHz	Not tested	Not tested	Not tested	Not tested
859.00000MHz	Not tested	Not tested	Not tested	Not tested
860.00000MHz	Not tested	Not tested	Not tested	Not tested
861.00000MHz	Not tested	Not tested	Not tested	Not tested

Frequency	Isolation	Max gain allowed	Use manual or auto
			Auto

DL Input / UL Input Test						
Site Name	Control CH Input (dBm)	Override	UL Input Test Result (dBm)	Radio TX PWR (dBm)	UL Input Range (dBm)	Override
Test	--	--	--	0	--	No

Uplink Input Test Setup:

Site Name:	Test	Site Address:	123 ABC Street
System Type:	P25 PHII	Isolation 700 and 800MHz (dB):	/
Donor Site TX ERP (dBm):	--	BDA Donor Antenna (dB):	--
Donor Site TX/RX Delta (dBm):	--	BDA Donor Cable Loss (dB):	--
Donor Site RX RSSI (dBm):	-- --	Distance to Donor Site / FSL (dB):	--/--

700MHz Channels

CH	Freq DL	SW	Filter	DL IN	DL GAIN	DL TAR	UL IN	UL GAIN	UL TAR	Desc.
1	769.50000	ON	12.5KHz	≤-110.00	75	30	≤-85.00	65	24	
2	770.00000	ON	12.5KHz	≤-110.00	75	30	≤-85.00	65	24	

800MHz Channels

CH	Freq DL	SW	Filter	DL IN	DL GAIN	DL TAR	UL IN	UL GAIN	UL TAR	Desc.
1	851.50000	ON	12.5KHz	≤-110.00	75	30	≤-85.00	65	24	
2	852.00000	ON	12.5KHz	≤-110.00	75	30	≤-85.00	65	24	

## 6.5 APPENDIX E: LIFEPO<sub>4</sub> BATTERY PRO-RATED 5 YEAR WARRANTY

### Warranty period

Comba Telecom warrants the Lithium Iron Phosphate (LiFePO<sub>4</sub>) batteries that are utilized in the Comba Version 2 and Version 3 Battery Backup Units for 5 years (60 months). The warranty period commences upon date of shipment from Comba Telecom.

For the first 2 years (24 months) of the warranty period, the battery will be replaced at no cost. For the period from month 25 (beginning of year 3) through the end of the 5-year (60 month) warranty period, the replacement battery will have a replacement cost that is pro-rated based on the amount of time the battery was in use, prior to failure.

### Terms and conditions of warranty

If the battery fails within the 2 years (24 month) Free Replacement period (commences upon ship date) for failure to perform due to defects in materials or workmanship, Comba Telecom will provide a new replacement battery of the same type at no charge except for shipping costs. In this case, the replacement battery will carry the remaining balance (3 years/36 months) of the original 5-year warranty.

If the battery fails after the 2 year (24 month) Free Replacement period, but prior to the termination of the 5-year (60 month) warranty period, for failure to perform due to defects in materials or workmanship, Comba will provide a replacement battery of the same type at a discounted replacement cost (plus shipping costs) per the replacement cost table at the end of this document. In these cases, the replacement battery will have a new full 5-year (60 month) warranty.

The warranty on the replacement battery will be in effect only if the battery is replaced by a certified/authorized Comba System Integrator. The System Integrator may charge the end user a fee for replacement of the battery.

The Comba certified integrator will receive the replacement battery for installation in the Comba BBU; the integrator will arrange for disposal of the defective battery.

### What IS covered under this warranty

- Failure of the battery to accept or hold a charge, provided the battery was used and maintained properly only in Comba Telecom BBU devices
- Failure of the battery to properly operate due to a malfunction of the internal battery management circuitry, including a short open circuit within the battery
- Mechanical failure of the case or connection points resulting in the battery being unusable – unless such failures are the result of misuse or abuse of the battery
- Deformation, breakage or other defects in the battery case
- Battery capacity is significantly lower than specified rating
- Loss of communications between the battery and the controller board
- Battery overheating
- Battery fire
- Any other battery defects that are confirmed by Comba Telecom

### What is NOT covered under this warranty

- Damage caused by abuse or misuse of the battery
- Damage to the battery caused by improper transportation by the customer
- Damage to the battery caused by incorrect polarity during battery installation
- Damage to the battery due to storing the battery and not charging the battery for more than 3 months
- Damage to the battery due to storing and/or using the battery in an improper environment:
  - Proper environment is defined as:
    - Proper operating temperatures: Between 32° F and 113° F
    - Proper storage temperatures: Between 32° F and 95° F
    - Relative humidity between 7% and 75%
- Damage to the battery caused by immersion in any liquids, or installation/use in close proximity to any chemicals or radiation
- Damage to the battery caused by natural disasters such as earthquake, fires, flooding, etc.
- Batteries to which any attempted removal, modification, or rewording of the labels affixed to the battery
- Destruction or damage to the battery by installation or servicing of the battery by a non Comba certified system integrator
- Destruction or damage to the battery caused by opening of or tampering with the battery case
- Unauthorized installation of or replacement of internal battery parts or components
- Destruction or damage to the battery caused by use of the battery with a non-Comba device of any type that is not authorized by Comba Telecom
- Testing of the battery using any method that is not authorized by Comba Telecom
- The attachment of any accessories to the battery or the battery backup unit that are not authorized by Comba Telecom
- Shipping costs for delivery of the replacement battery to the designated address

### What is NOT covered under this warranty (continued)

- Labor or service charges that may be charged by the certified system integrator for:
- Removal and disposal of the failed battery
- Installation and setup of the replacement battery
- Travel costs or site visit costs
- The BBU (Battery Backup Unit) device – warranty for the BBU chassis that is covered by a separate 3-year warranty (see Comba Telecom standard warranty statement document for details on the BBU warranty)
- **LIABILITY DISCLAIMER**
- The end user recognizes that Comba Telecom is not the manufacturer of the LiFePO<sub>4</sub> battery, and as such Comba Telecom declares that it has no liability for damages related to a malfunction of the battery.
- Comba Telecom is expressly not liable for any harm or damage to persons, property or other equipment resulting from any fires or other damage caused by the LiFePO<sub>4</sub> battery
- The end user may be able to collect damages directly from the battery manufacturer

### How to order a replacement battery

- Call Comba customer service at: (408) 526-0180 - Extension 1
- Provide the size (capacity) of your current battery (30AH, 60AH or 100AH); provide the serial number of your BBU system
- The Comba Customer Service representative can inform you of the price of the replacement battery, arrange for the sale of the battery via a credit card, and arrange for shipping the battery to you.

### Comba Telecom LiFePO<sub>4</sub> Battery Pro-rated Warranty Replacement Cost Schedule

Replacement cost will be the indicated percentage of the current battery price - contact Comba Customer service for a quote and to order a battery.

Battery failure month	30AH Replacement cost	60AH Replacement cost	100AH Replacement cost
1 - 24	N/C	N/C	N/C
25	42%	42%	42%
26	43%	43%	43%
27	45%	45%	45%
28	47%	47%	47%
29	48%	48%	48%
30	50%	50%	50%
31	52%	52%	52%
32	53%	53%	53%
33	55%	55%	55%
34	57%	57%	57%
35	58%	58%	58%
36	60%	60%	60%
37	62%	62%	62%
38	63%	63%	63%
39	65%	65%	65%
40	67%	67%	67%
41	68%	68%	68%
42	70%	70%	70%
43	72%	72%	72%
44	73%	73%	73%
45	75%	75%	75%
46	77%	77%	77%
47	78%	78%	78%
48	80%	80%	80%
49	82%	82%	82%
50	83%	83%	83%
51	85%	85%	85%
52	87%	87%	87%
53	88%	88%	88%
54	90%	90%	90%
55	92%	92%	92%
56	95%	95%	95%
57	95%	95%	95%
58	97%	97%	97%
59	98%	98%	98%
60	100%	100%	100%

End of Section

## 6.6 APPENDIX F: LIFEPO<sub>4</sub> BATTERY DATASHEETS

Capacity: 30Ah – Model Number: TB4830F-T107A\_UL

### TOPBAND 拓邦

#### 1. General Information

This specification defines the performance of rechargeable LiFePO<sub>4</sub> battery pack TB4830F-T107A\_UL manufactured by SHENZHEN TOPBAND BATTERY CO.,LTD.

#### 2. Battery Specification (@ 25±5°C)

NO	Items	Characteristics
2.1	Normal capacity	30 Ah
2.2	Nominal energy	1.536 KWh
2.3	Nominal voltage	51.2 V
2.4	Internal resistance	≤50mΩ
2.5	Normal charge voltage	56.0~57.6V, default: 56.4V
2.6	Float charge voltage	54.4~55.2V, default: 54.4V
2.7	Allowed MAX charge current <sup>1</sup>	20A
2.8	Recommend Charge current	≤6A
2.9	Allowed MAX discharge current <sup>2</sup>	20A
2.10	Terminal	2P*M6
2.11	Charging method	Phase 1: CC-CV Phase 2: FLOAT/ Regular bulk charge
2.12	End of discharge voltage	LLVD: 49~50V BLVD: 45~46V
2.13	IP rating	IP2X
2.14	Communication and Display	RS485
2.15	Dimension	W 559.0±2 mm
		H 221.5±2 mm
		D 225.0±2 mm
2.16	Weight ( without accessory )	24 ± 1Kg
2.17	Operation temperature <sup>4</sup>	Charge
		Discharge
2.18	Self-discharge rate	Residual capacity
		Recover capacity
2.19	Storage environment (Power off status)	≤6 months
		≤3 months
		0~10°C: ≤0.1C(Force)
		10~20°C: ≤0.3C(Recommend)
		20~35°C: ≤0.5C(Recommend)
		35~45°C: ≤0.2C(Recommend)
		0~45°C
		-10~55°C
		≤3%/Month; ≤15%/ year
		≤1.5%/Month; ≤8%/ year
		0°C<T<30°C
		-10°C<T<45°C

**Capacity: 30Ah – Model Number: TB4830F-T107A\_UL**

## TOPBAND 拓邦

		Recommend environment	15~35℃、5~75%RH
2.20	Cycle life	Performance life	7 years+
		Design life	10 years+

<sup>1&2</sup> is based on the initial environment temp. 25±5℃.

<sup>3</sup> the batteries recommend a full charge per month, we suggest you to charge the batteries to correct SOC.

<sup>4</sup> Battery pack will stop work to protect itself when the temperature is out of the operation range. The optimum operating temperature range is from 15℃ to 35℃, Frequent exposure to the harsh temperatures may worsen the performance of the battery pack and cycle life.

### 3. Electrical parameters

No	Item	Content	Criterion
4.1	Over charge	Over-charge protection Alarm	57.6V
		Over-charge protection	58.4V
		Over-charge protection delay time	1.0S
		Over-charge release	54.0V
		Over-charge release method	Discharge
4.2	Over discharge	Over-discharge protection alarm	44.8V
		Over-discharge protection	43.2V
		Over-discharge protection delay time	1.0S
		Over-discharge release	47.2V
		Over-discharge release method	Charge recovering
4.3	Over current	Charge over current protection alarm	25A
		Charge over current protection	30A
		Charge over current protection delay time	3.0S
		Charge over current release method	about 60s later
		Charge limitation current	N/A
		Discharge over current protection alarm	25A
		Discharge over current protection1	30A
		Discharge over current protection delay time1	3.0S
		Discharge over current release1	Recover in 60s after charging or removing the load
		Discharge over current protection2	≥60A
		Discharge over current protection delay time2	500ms
		Discharge over current release2	Recover in 60s after charging or removing the load
		Short circuit protection	Available
Short circuit protection release	Available		
4.4	Temperature	Charge over temperature protection	Protect@65℃; Release@55℃;
		Charge under temperature protection	Protect@-5℃; Release@0℃
		Discharge over temperature protection	Protect@75℃; Release@60℃;
		Discharge under temperature protection	Protect@-20℃; Release@-10℃;

Capacity: 30Ah – Model Number: TB4830F-T107A\_UL

# TOPBAND 拓邦

## 5. Dimension

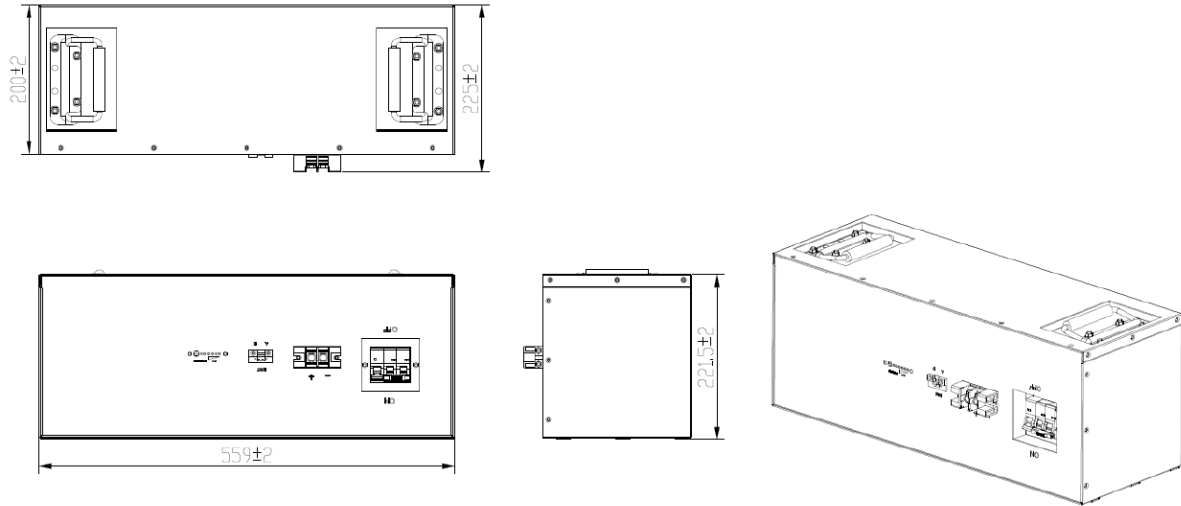

Capacity: 60Ah – Model Number: TB4860F-T104A\_UL

## TOPBAND 拓邦

### 1. General Information

This specification defines the performance of rechargeable LiFePO4 battery pack TB4860F-T104A\_UL manufactured by SHENZHEN TOPBAND BATTERY CO.,LTD.

### 2. Battery Specification (@ 25±5°C)

NO	Items	Characteristics		
2.1	Normal capacity	60 Ah		
2.2	Nominal energy	3.072 KWh		
2.3	Nominal voltage	51.2 V		
2.4	Internal resistance	≤70mΩ		
2.5	Normal charge voltage	56.0~57.6V, default: 56.4V		
2.6	Float charge voltage	54.4~55.2V, default: 54.4V		
2.7	Allowed MAX charge current <sup>1</sup>	30A		
2.8	Recommend Charge current	≤10A		
2.9	Allowed MAX discharge current <sup>2</sup>	50A		
2.10	Terminal	2P*M6		
2.11	Charging method	Phase 1: CC-CV Phase 2: FLOAT/ Regular bulk charge		
2.12	End of discharge voltage	LLVD: 49~50V BLVD: 45~46V		
2.13	IP rating	IP2X		
2.14	Communication and Display	RS485		
2.15	Dimension	W 559.0±2 mm		
		H 221.5±2 mm		
		D 242.0±2 mm		
2.16	Weight ( without accessory )	TBD ±1Kg		
2.17	Operation temperature <sup>3</sup>	Charge	0~45°C	0~10°C: ≤0.1C(Force) 10~20°C: ≤0.3C(Recommend) 20~35°C: ≤0.5C(Recommend) 35~45°C: ≤0.2C(Recommend)
		Discharge	-10~55°C	
2.18	Self-discharge rate	Residual capacity	≤3%/Month; ≤15%/ year	
		Recover capacity	≤1.5%/Month; ≤8%/ year	
2.19	Storage environment (Power off status)	≤6 months	0°C<T<30°C	
		≤3 months	-10°C<T<45°C	

Capacity: 60Ah – Model Number: TB4860F-T104A\_UL

## TOPBAND 拓邦

		Recommend environment	15~35℃、5~75%RH
2.20	Cycle life	Performance life	7 years+
		Design life	10 years+

<sup>1</sup> & <sup>2</sup> is based on the initial environment temp. 25±5℃.

<sup>3</sup> the batteries recommend a full charge per month, we suggest you to charge the batteries to correct SOC.

<sup>4</sup> Battery pack will stop work to protect itself when the temperature is out of the operation range. The optimum operating temperature range is from 15°C to 35°C, Frequent exposure to the harsh temperatures may worsen the performance of the battery pack and cycle life.

## 3. Electrical parameters

No	Item	Content	Criterion
4.1	Over charge	Over-charge protection Alarm	57.6V
		Over-charge protection	58.4V
		Over-charge protection delay time	1.0S
		Over-charge release	54.0V
		Over-charge release method	Discharge
4.2	Over discharge	Over-discharge protection alarm	44.8V
		Over-discharge protection	43.2V
		Over-discharge protection delay time	1.0S
		Over-discharge release	47.2V
		Over-discharge release method	Charge recovering
4.3	Over current	Charge over current protection alarm	50A
		Charge over current protection	55A
		Charge over current protection delay time	3.0S
		Charge over current release method	about 60s later
		Charge limitation current	N/A
		Discharge over current protection alarm	50A
		Discharge over current protection1	55A
		Discharge over current protection delay time1	3.0S
		Discharge over current release1	Recover in 60s after charging or removing the load
		Discharge over current protection2	≥75A
		Discharge over current protection delay time2	500ms
		Discharge over current release2	Recover in 60s after charging or removing the load
		Short circuit protection	Available
Short circuit protection release	Available		
4.4	Temperature	Charge over temperature protection	Protect@65℃; Release@55℃;
		Charge under temperature protection	Protect@-5℃; Release@0℃
		Discharge over temperature protection	Protect@75℃; Release@60℃;
		Discharge under temperature protection	Protect@-20℃; Release@-10℃;

Capacity: 60Ah – Model Number: TB4860F-T104A\_UL

# TOPBAND 拓邦

## 5. Dimension

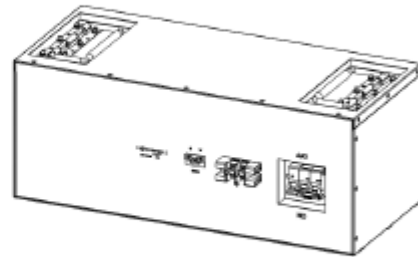
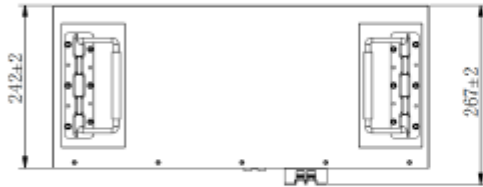

Capacity: 100Ah – Model Number: TB48100F-T102A\_UL

## TOPBAND 拓邦

### 1. General Information

This specification defines the performance of rechargeable LiFePO<sub>4</sub> battery pack TB48100F-T102A\_UL manufactured by SHENZHEN TOPBAND BATTERY CO., LTD.

### 2. Battery Specification (@ 25±5°C)

NO	Items	Characteristics		
2.1	Normal capacity	100 Ah		
2.2	Nominal energy	5.12 KWh		
2.3	Nominal voltage	51.2 V		
2.4	Internal resistance	≤50mΩ		
2.5	Normal charge voltage	56.0~57.6V, default: 56.4V		
2.6	Float charge voltage	54.4~55.2V, default: 54.4V		
2.7	Allowed MAX charge current <sup>1</sup>	50A		
2.8	Recommend Charge current	≤10A		
2.9	Allowed MAX discharge current <sup>2</sup>	50A		
2.10	Terminal	2P*M6		
2.11	Charging method	Phase 1: CC-CV Phase 2: FLOAT/ Regular bulk charge		
2.12	End of discharge voltage	LLVD: 49~50V BLVD: 45~46V		
2.13	IP rating	IP2X		
2.14	Communication and Display	RS485		
2.15	Dimension	W 559.0±2 mm		
		H 250.5±2 mm		
		D 252.0±2 mm		
2.16	Weight ( without accessory )	54 ± 1Kg		
2.17	Operation temperature <sup>4</sup>	Charge	0~45°C	0~10°C: ≤0.1C(Force) 10~20°C: ≤0.3C(Recommend) 20~35°C: ≤0.5C(Recommend) 35~45°C: ≤0.2C(Recommend)
		Discharge	-10~55°C	
2.18	Self-discharge rate	Residual capacity	≤3%/Month; ≤15%/ year	
		Recover capacity	≤1.5%/Month; ≤8%/ year	
2.19	Storage environment (Power off status)	≤6 months	0°C<T<30°C	
		≤3 months	-10°C<T<45°C	

Capacity: 100Ah – Model Number: TB48100F-T102A\_UL

## TOPBAND 拓邦

		Recommend environment	15~35℃、5~75%RH
2.20	Cycle life	Performance life	7 years+
		Design life	10 years+

<sup>1</sup> & <sup>2</sup> are based on the initial environment temp. 25±5℃.

<sup>3</sup> the batteries recommend a full charge per month; we suggest you charge the batteries to correct SOC.

<sup>4</sup> Battery pack will stop work to protect itself when the temperature is out of the operation range. The optimum operating temperature range is from 15℃ to 35℃, Frequent exposure to the harsh temperatures may worsen the performance of the battery pack and cycle life.

### 3. Electrical parameters

No	Item	Content	Criterion
4.1	Over charge	Over-charge protection Alarm	57.6V
		Over-charge protection	58.4V
		Over-charge protection delay time	1.0S
		Over-charge release	54.0V
		Over-charge release method	Discharge
4.2	Over discharge	Over-discharge protection alarm	44.8V
		Over-discharge protection	43.2V
		Over-discharge protection delay time	1.0S
		Over-discharge release	47.2V
		Over-discharge release method	Charge recovering
4.3	Over current	Charge over current protection alarm	50A
		Charge over current protection	55A
		Charge over current protection delay time	3.0S
		Charge over current release method	about 60s later
		Charge limitation current	N/A
		Discharge over current protection alarm	50A
		Discharge over current protection1	55A
		Discharge over current protection delay time1	3.0S
		Discharge over current release1	Recover in 60s after charging or removing the load
		Discharge over current protection2	≥75A
		Discharge over current protection delay time2	500ms
		Discharge over current release2	Recover in 60s after charging or removing the load
		Short circuit protection	Available
Short circuit protection release	Available		
4.4	Temperature	Charge over temperature protection	Protect@65 ℃; Release@55 ℃;
		Charge under temperature protection	Protect@-5 ℃; Release@0 ℃
		Discharge over temperature protection	Protect@75 ℃; Release@60 ℃;
		Discharge under temperature protection	Protect@-20 ℃; Release@-10 ℃;

6.7 APPENDIX G: COMBA V3 BDA/MU/RU WIRING DIAGRAMS

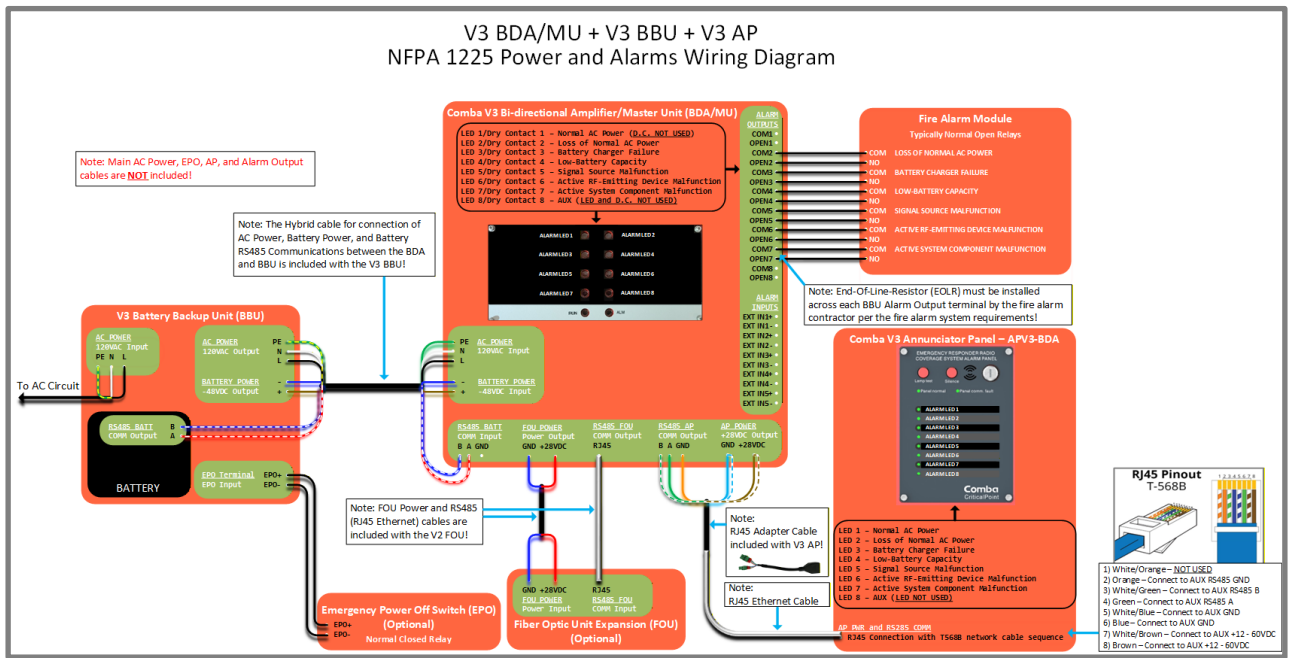
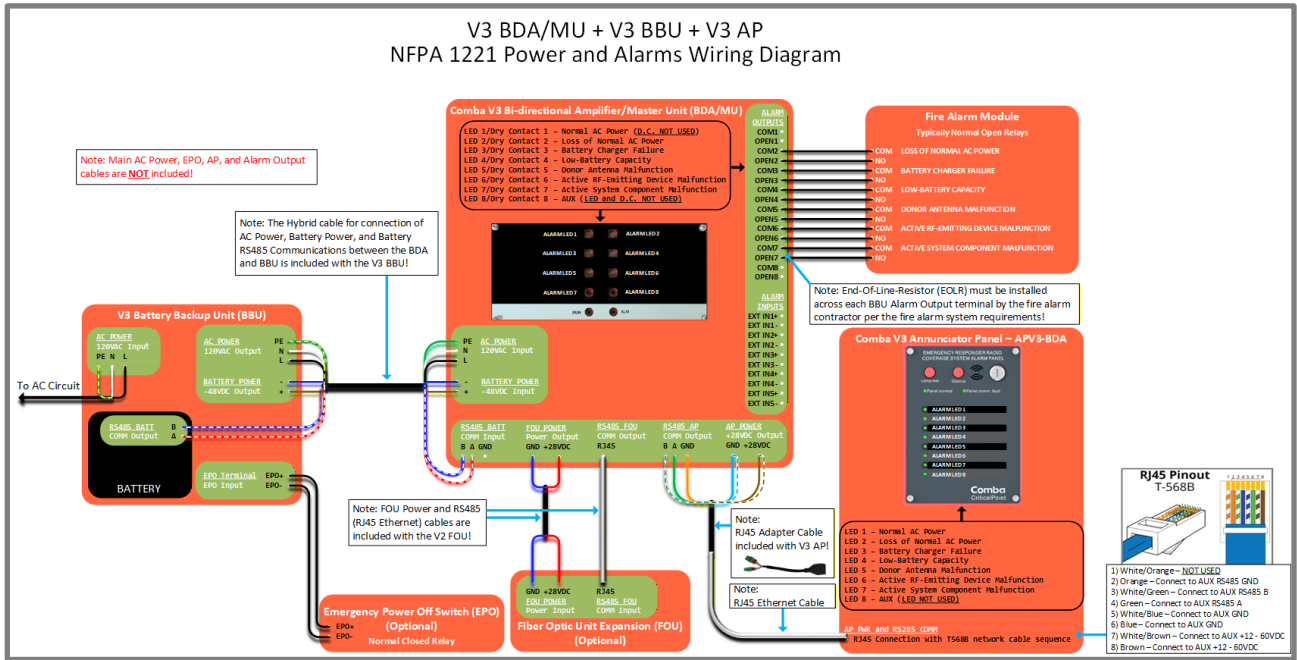

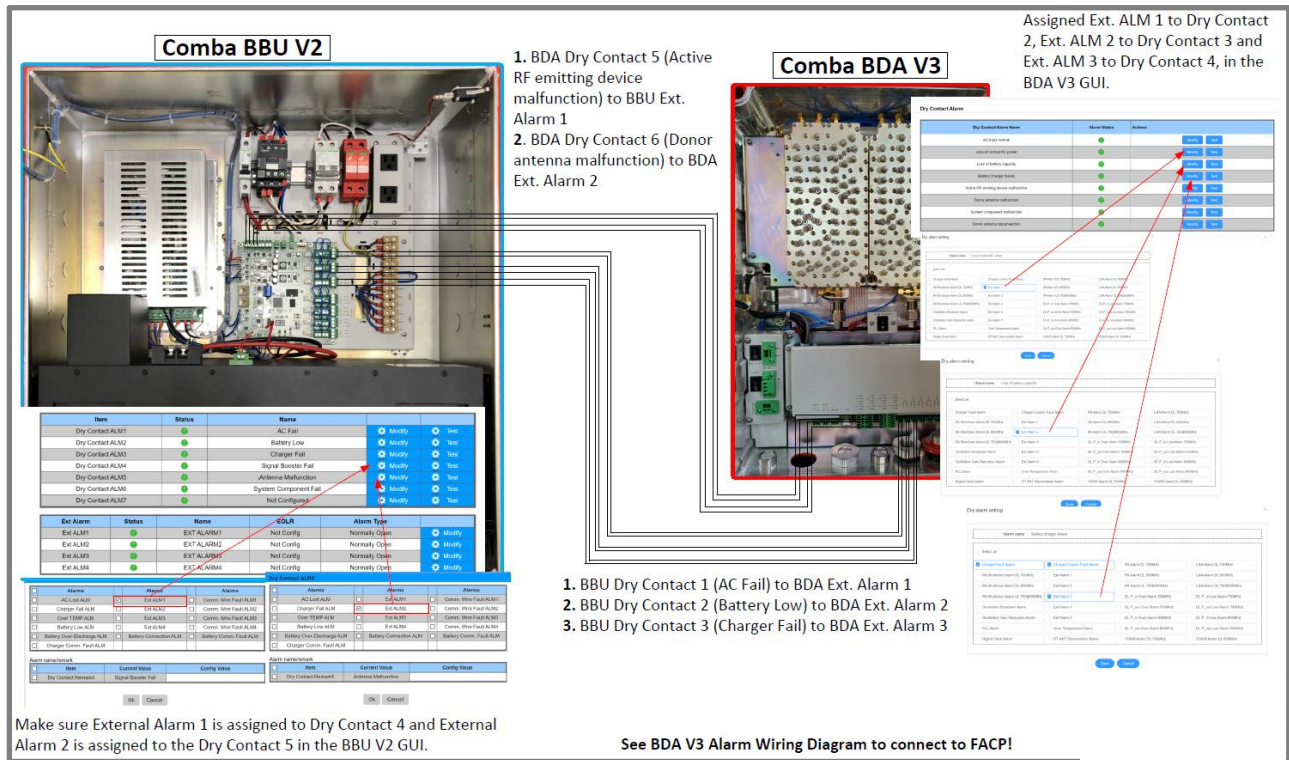
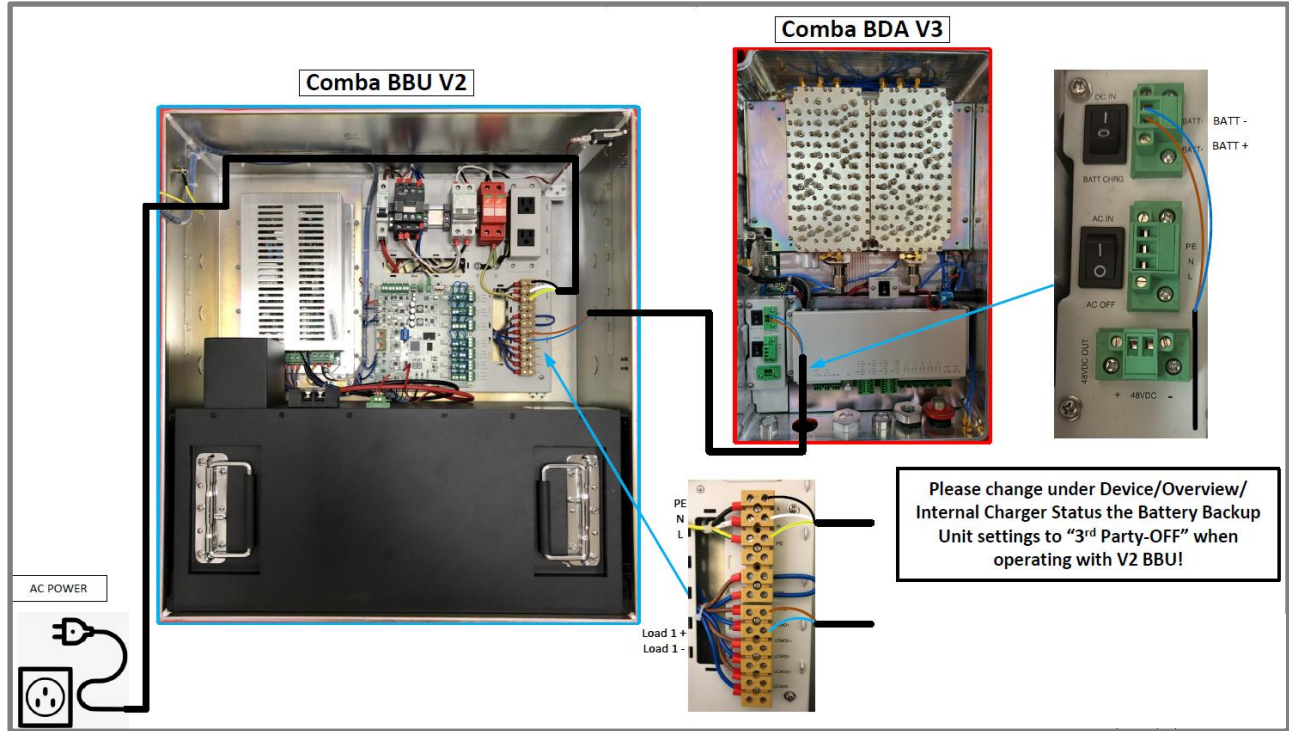

V3 VHF/UHF BDA + V3 700/800 BDA + V2 BBU + V3 AP  
Power and Alarms Wiring Diagram (Independent BDA Alarms to FACP)

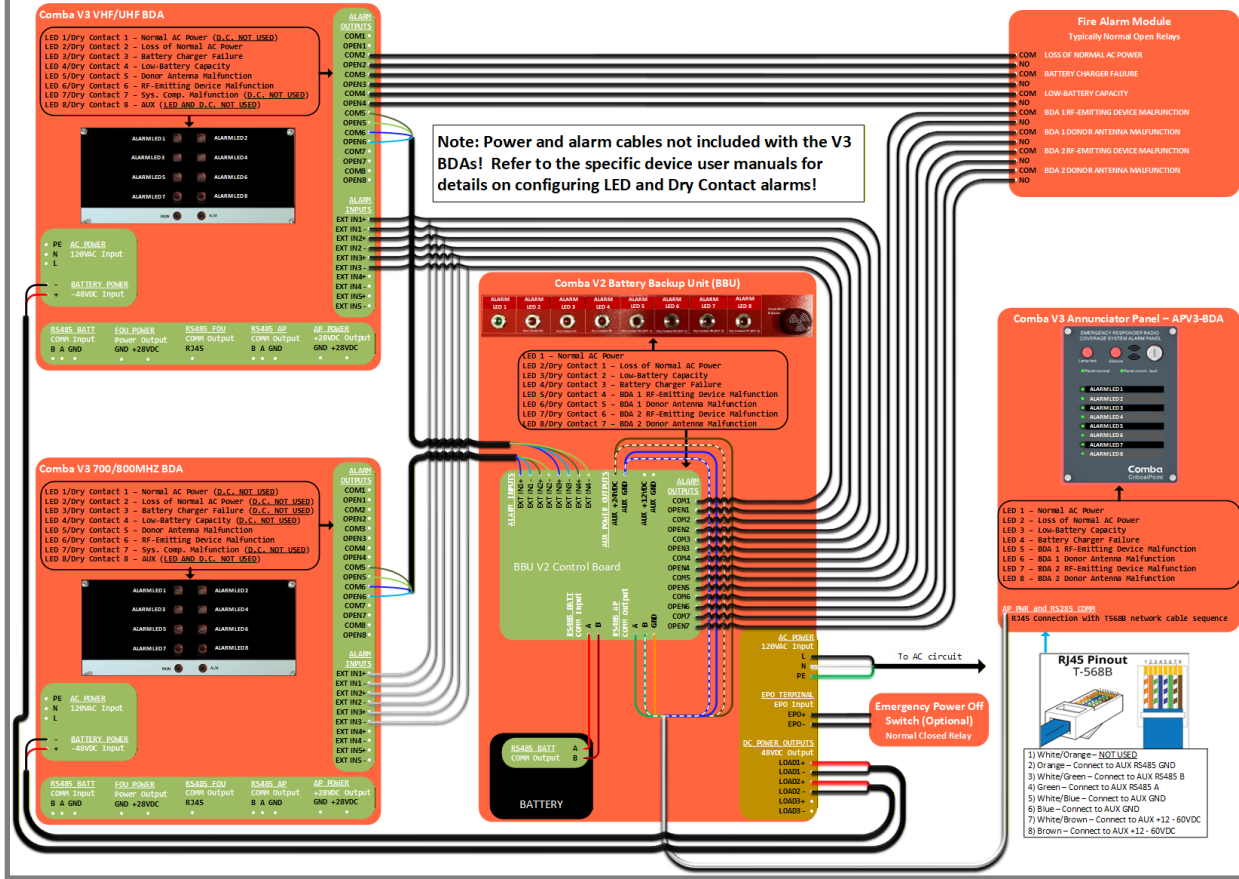

V3 VHF/UHF BDA + V3 700/800 BDA + V2 BBU + V3 AP  
NFPA 1221 Power and Alarms Wiring Diagram

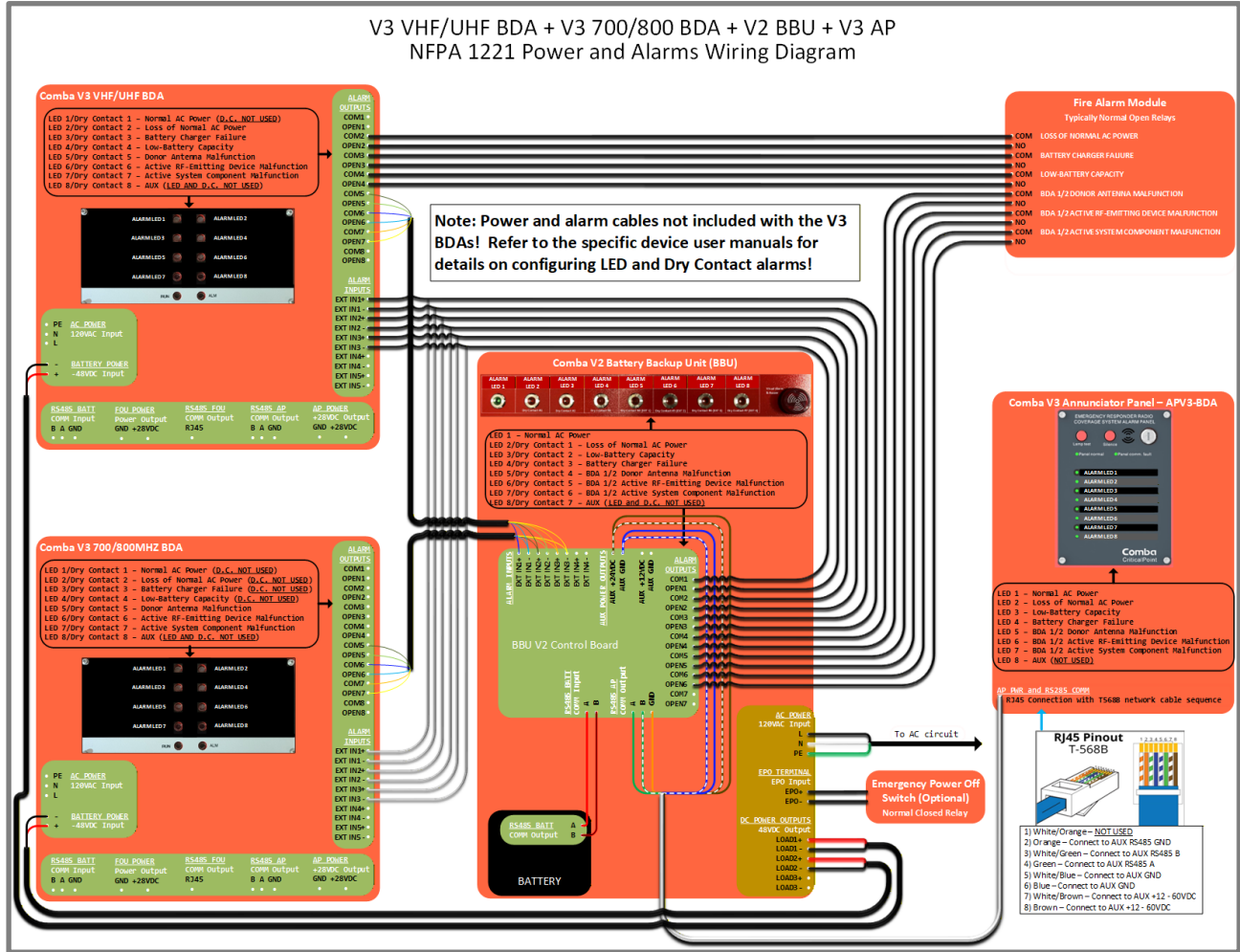

V3 VHF/UHF BDA + V3 700/800MHz BDA + V2 BBU + V3 AP NFPA 1225 Power and Alarms Wiring Diagram

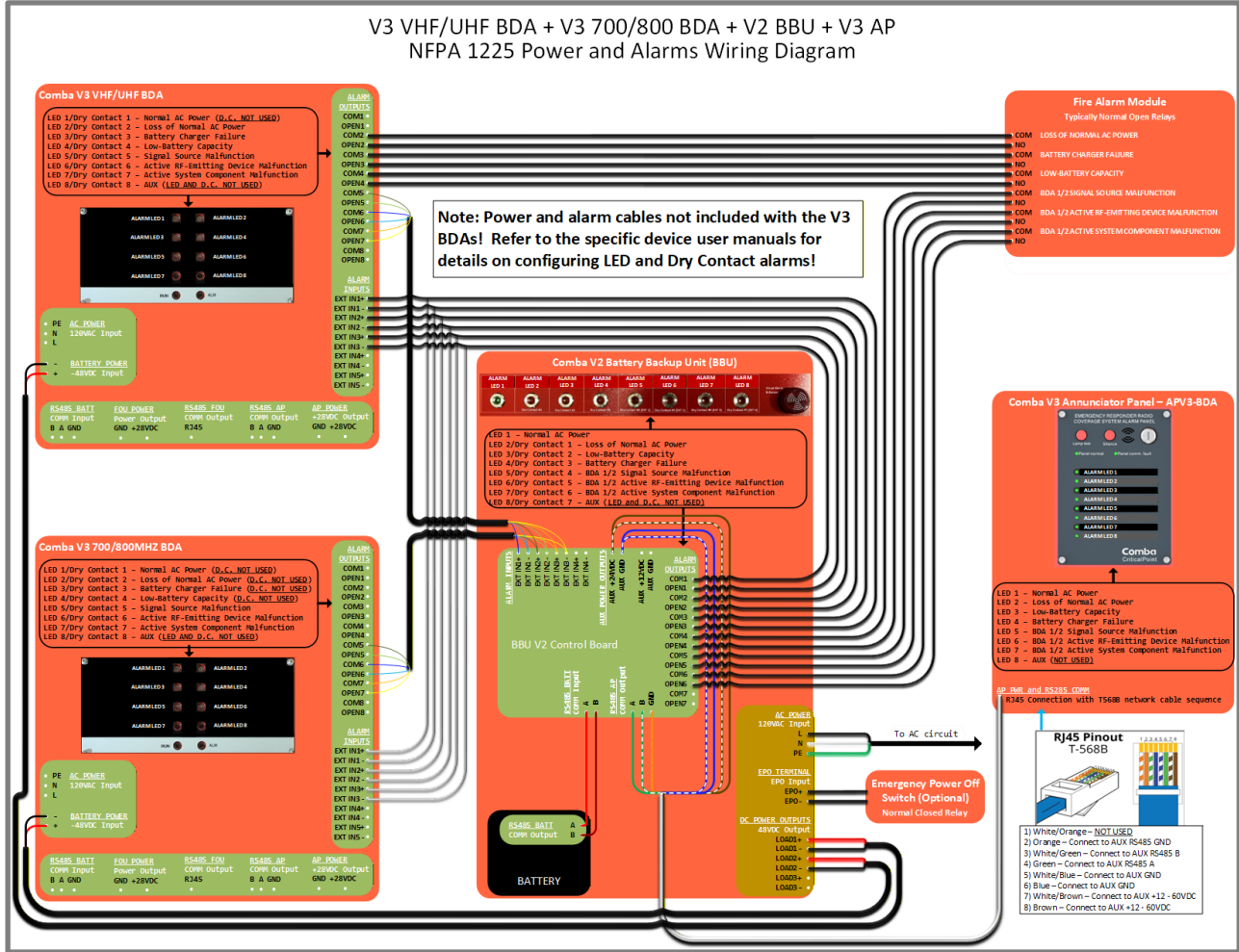

V3 VHF/UHF BDA + V3 700/800 BDA + V2 BBU + V1 AP  
Power and Alarms Wiring Diagram (Independent BDA Alarms at FACP)

Note: Power and alarm cables not included with the V3 BDAs! Refer to the specific device user manual for details on configuring LED and Dry Contact alarms!

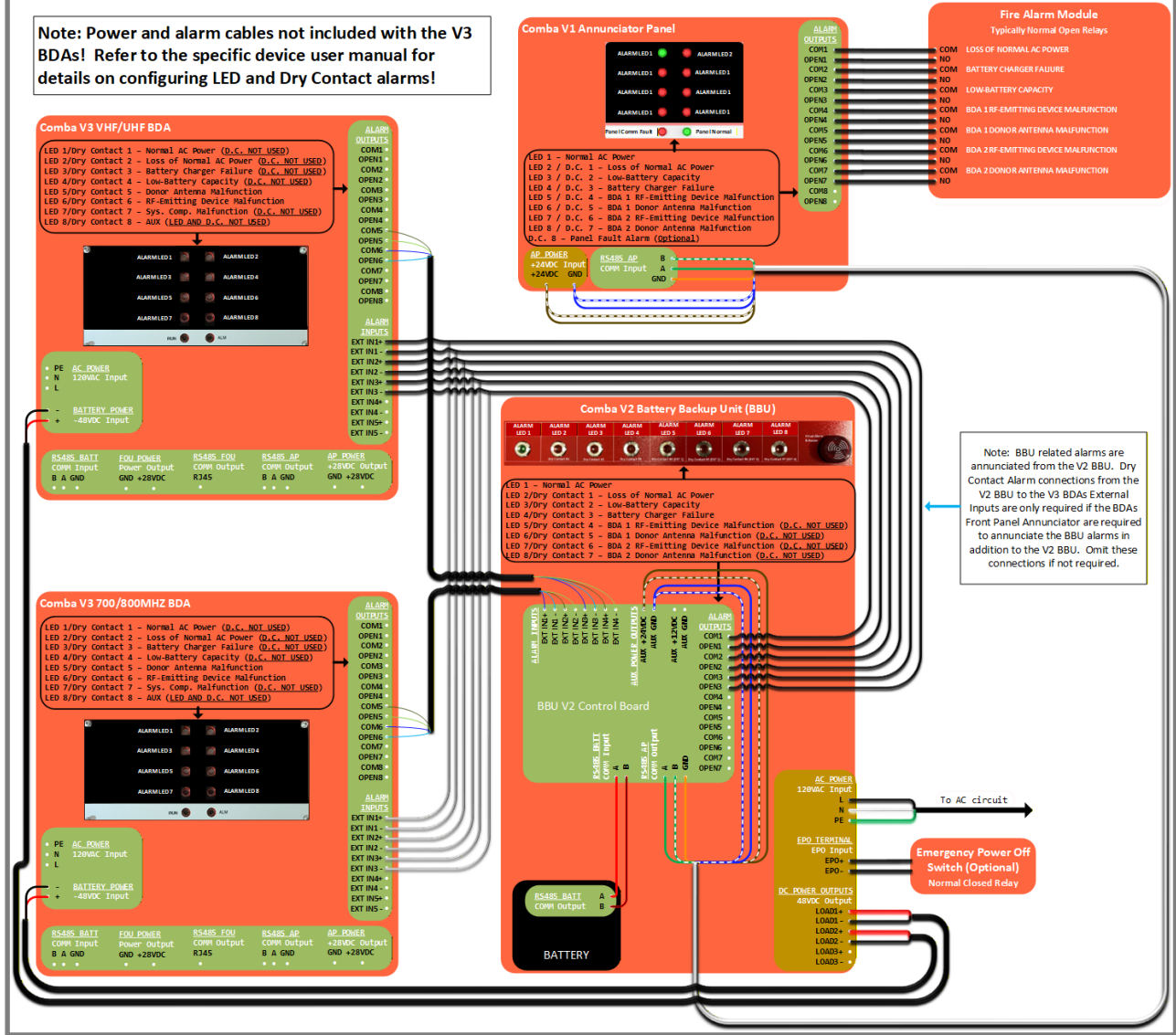

Note: BBU related alarms are annunciated from the V2 BBU. Dry Contact Alarm connections from the V2 BBU to the V3 BDAs External Inputs are only required if the BDAs Front Panel Annunciator are required to annunciate the BBU alarms in addition to the V2 BBU. Omit these connections if not required.

V3 VHF/UHF BDA + V3 700/800 BDA + V2 BBU + V1 AP  
NFPA1221 Power and Alarms Wiring Diagram

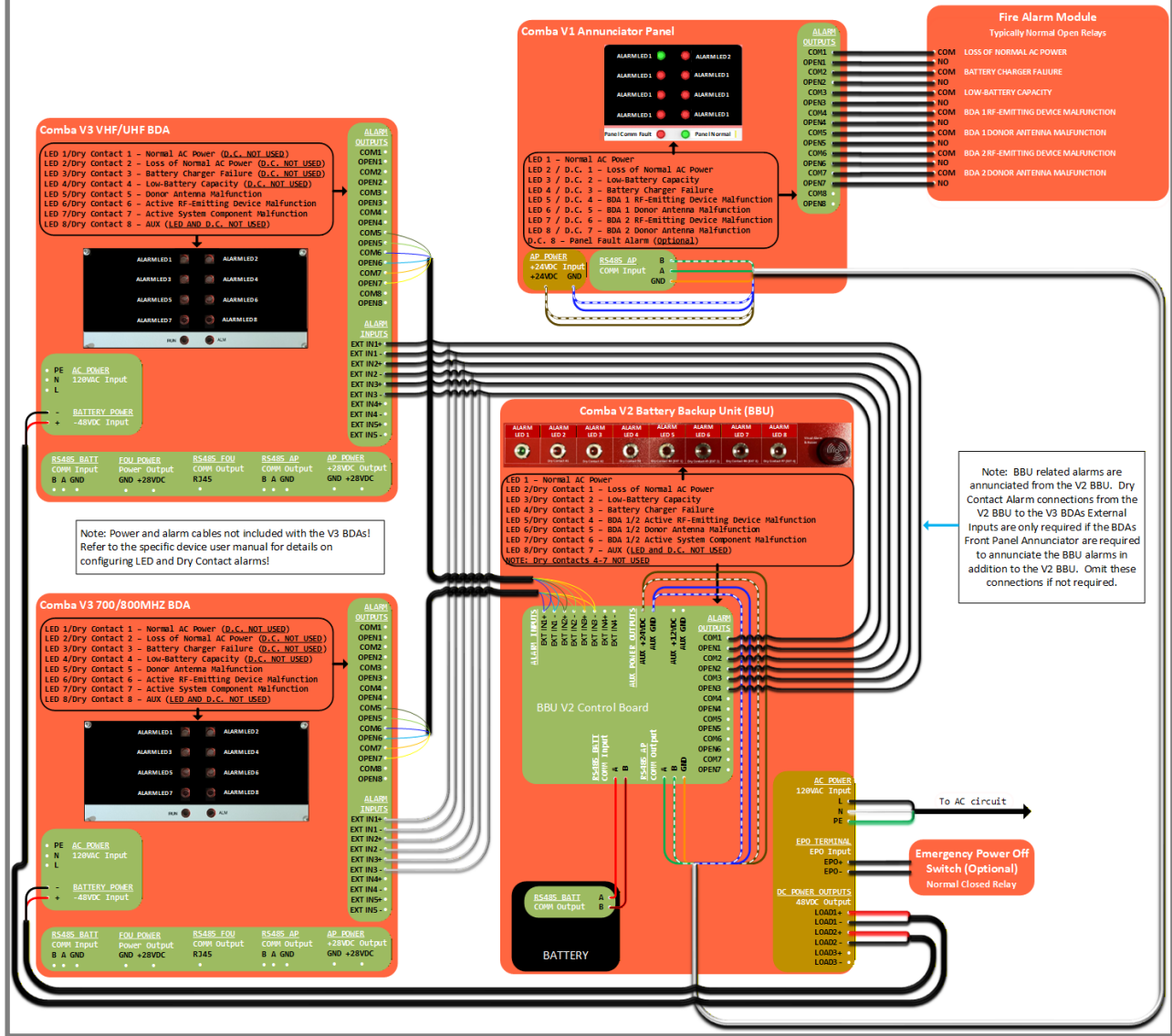

6.8 APPENDIX H: V3 BDA – AUTO DIALER WIRING DIAGRAM

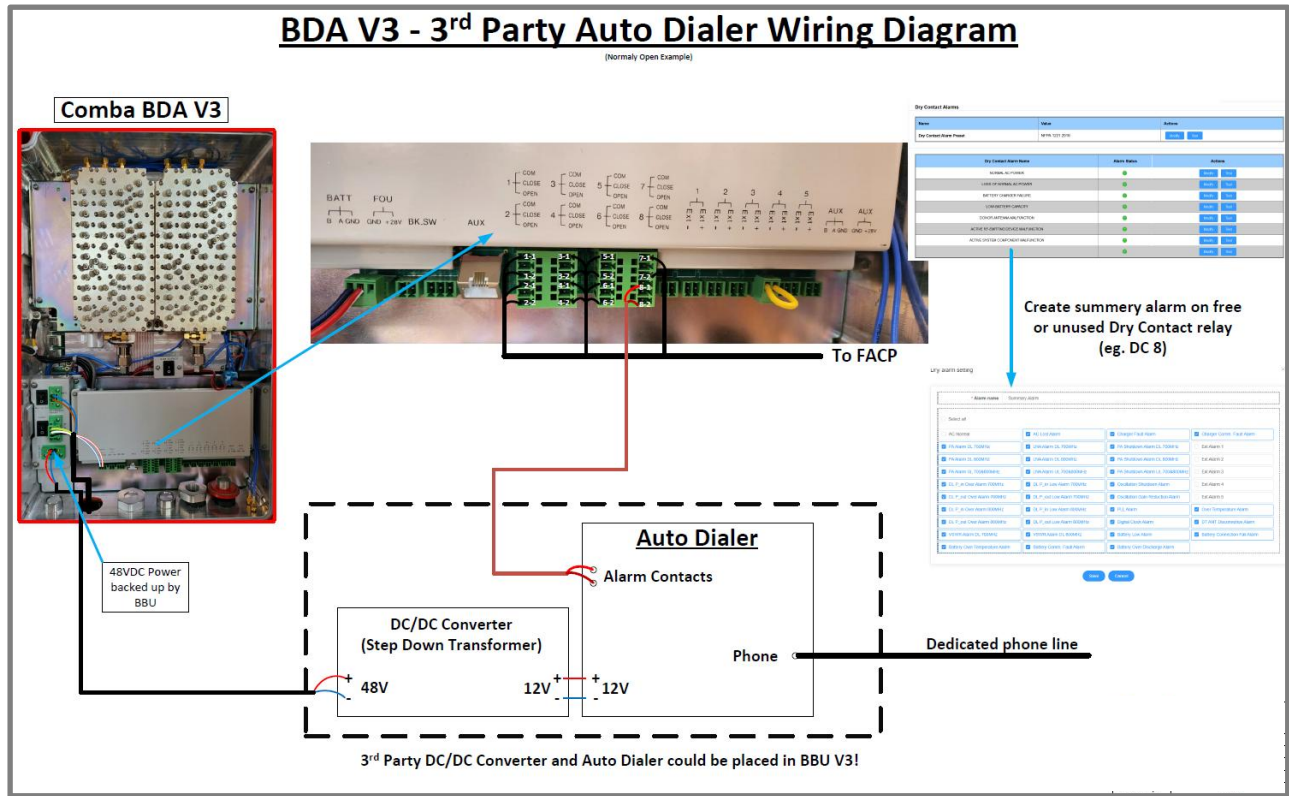

## 6.9 APPENDIX I: V3 BBU BATTERY RUNTIME CALCULATIONS EXAMPLE

The following example explains how to calculate the required Battery Capacity for a V3 BDA/BBU System based on the Total Power Consumption, Device Operating Voltage and Backup Runtime requirement (e.g. 12 or 24 hours). Once the required Battery Capacity is calculated, the correct battery option can be chosen, and the true battery backup runtime should be calculated based on the chosen battery capacity.

Power (W) = Power Consumption in Watts

DC Voltage (VDC) = DC Operating Voltage of Device

Current (A) = Total Current in Amps

Battery Runtime (hr) = Duration of Power provided at 100-percent capacity in hours

Safety Factor (%) = Percent margin required to account for battery aging (refer to local AHJ requirements)

Battery Capacity (Ah) = Total Battery Capacity a battery can provide in Amp/Hr

**Step 1:** Calculate the Total Power Consumption of the system by adding up the power consumption of all the devices which will be connected to the BBU (BDA/MU, Annunciator Panel, FOUs, etc...). Refer to the device datasheets for Power Consumption values.

**Step 2:** Calculate the Total Current that the system will draw in Amps based on the Total Power Consumption and 48VDC system operating voltage.

**Step 3:** Calculate the required Battery Capacity to meet the Backup Runtime requirements.

**Step 4:** Choose the correct Battery option based on the calculated Battery Capacity.

**Step 5:** Calculate the true Battery Backup Runtime based on the chosen battery.

**Example 1:** We are using a VHF/UHF Dual Band BDA/MU connected to two (2) FOUs (8 fiber Ports Each) and one (1) V1 AP, all of which will be powered from a single Comba V3 BBU. The local jurisdiction has a requirement to provide a minimum of 12 hours of Backup Runtime with a Safety Margin of 20%. Comba devices use a 48VDC operating voltage. We must first look at each device datasheet to determine the power consumption.

Power Consumption – VHF/UHF Dual Band BDA/MU: **120 Watts**

Power Consumption – 8-Port FOU: **20W**

Power Consumption – AP: **3W**

Total Power Consumption = BDA/MU Power Consumption + 2 x FOU Power Consumption + AP Power Consumption

Total Power Consumption = 120 + 20 + 20 + 3 = **163 Watts**

Current = Total Power Consumption / Voltage = 163 Watts / 48VDC = **3.4 A**

Safety Factory of 20% = 1 + % / 100 = 1 + 20/100 = **1.2**

Battery Capacity Required = Current x Battery Runtime x Safety Factor = 3.4 A x 12 hr x 1.2 = **48.96 Ah**

**Now you will choose the battery that has at least 48.96Ah of Battery Capacity. In this case, you would choose the Comba 60Ah battery option, as the 30Ah battery does not have enough capacity to meet the requirements.**

Backup Runtime (hr) = Battery Capacity / Total Current / Safety Factor = 60 Ah / 3.4 A / 1.2 = **14.71 hr**

Note: If there is *not* a requirement to include a Safety Factor, then simply remove it from the calculations.

Battery Capacity Required = I x Battery Runtime = 3.4 A x 12 hr = **40.8 Ah**

Backup Runtime (hr) = Battery Capacity / Total Current = 60 Ah / 3.4 A = **17.65 hr**

6.10 APPENDIX J: V3 BDA/MU/RU AND BBU DOOR STICKER WIRING GUIDE

For installation convenience, there is a device wiring reference guide sticker located on the inside of the door on the V3 BDA/MU and RU devices. The installer/operator can refer to this sticker to verify proper wire connections.

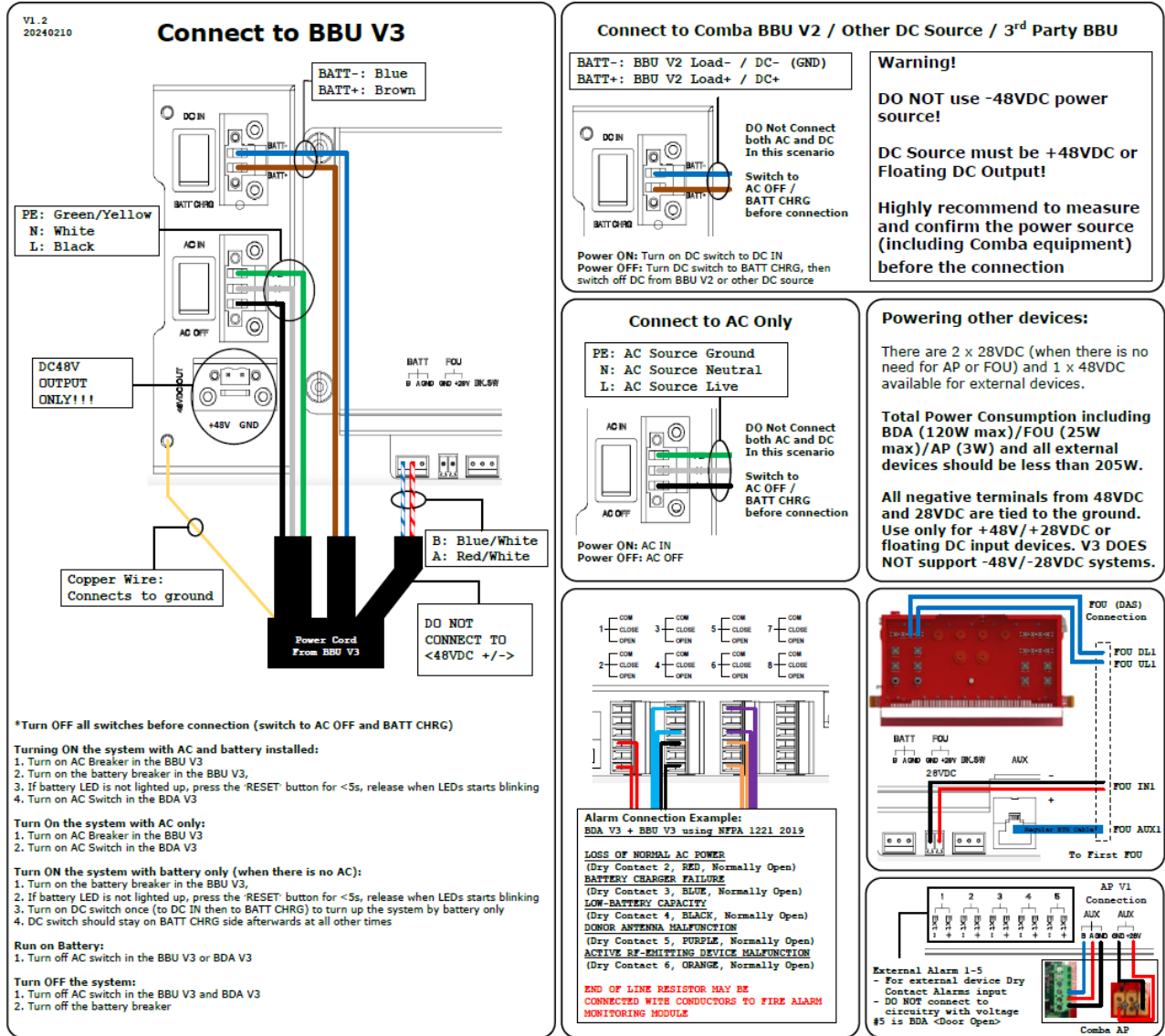

Figure 196: V3 BDA/MU/RU Wiring Reference Door Sticker

For installation convenience, there is a device wiring reference guide sticker located on the inside of the door on the V3 BBU devices. The installer/operator can refer to this sticker to verify proper wire connections.

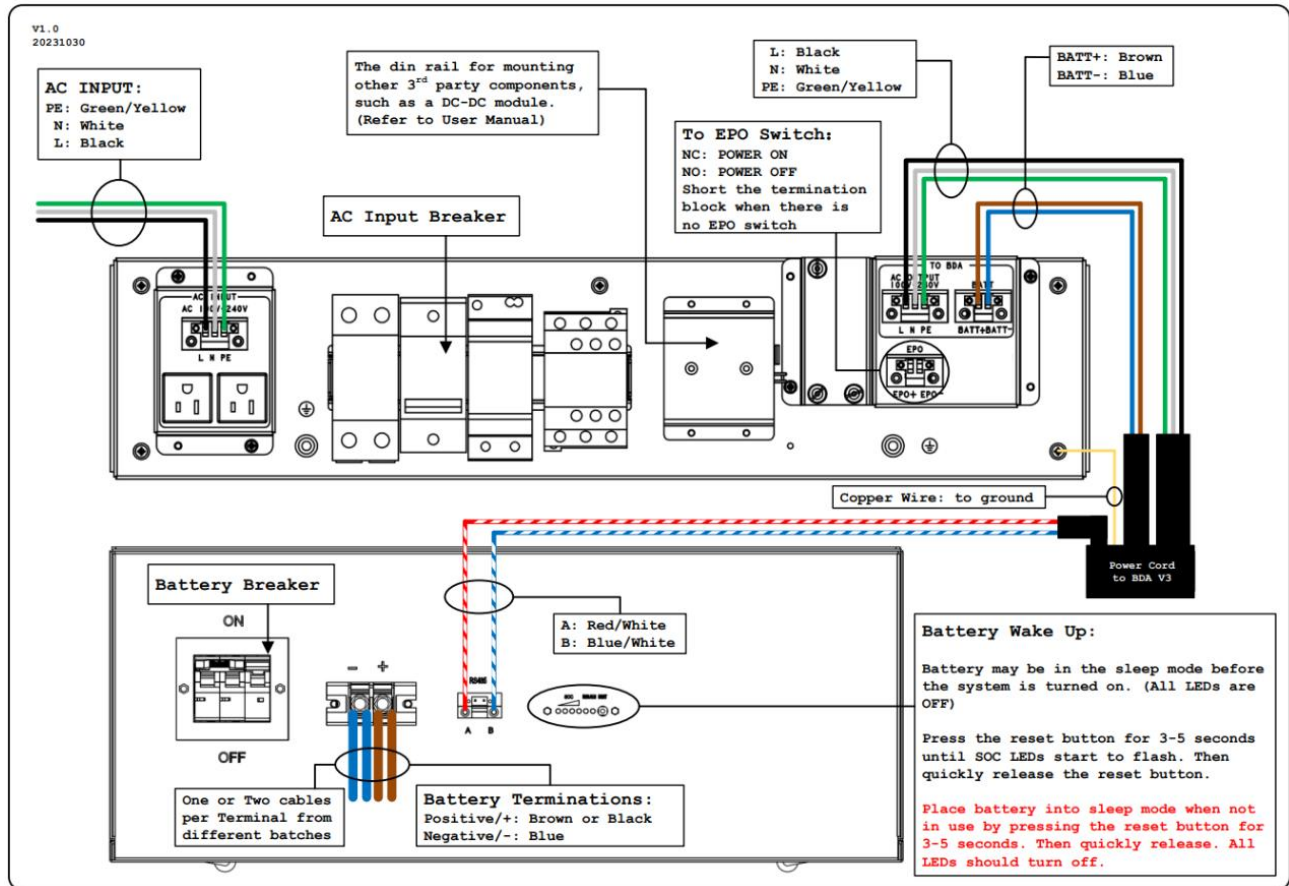

Figure 197: V3 BBU Wiring Reference Door Sticker

## 6.11 APPENDIX K: V3 FIBER INSTALLATION ADVICE

### Best Practices for Public Safety and Cellular Analog Fiber DAS Deployment – Fiber Plant Installation

#### Introduction:

The purpose of this document is to highlight the proper installation and end-to-end testing of the fiber plant (aka, fiber backhaul) that is used to optically connect the analog fiber master unit to the analog fiber remote unit(s). Improper fiber installation and testing will result in increased system integrator troubleshooting and installation costs, and cause communication performance issues between the fiber master and fiber remote DAS equipment. It is imperative that proper cleaning techniques and end-to-end fiber testing on the installed fiber plant (which includes patch panel(s), patch cable(s), fusion splice(s), and connectors) are performed.

#### Fiber Plant:

For an analog fiber DAS solution, the fiber plant must be deployed with Single-Mode fiber and terminated with SC/APC (Angle Physical Contact or Angle Polished Connector) connectors.

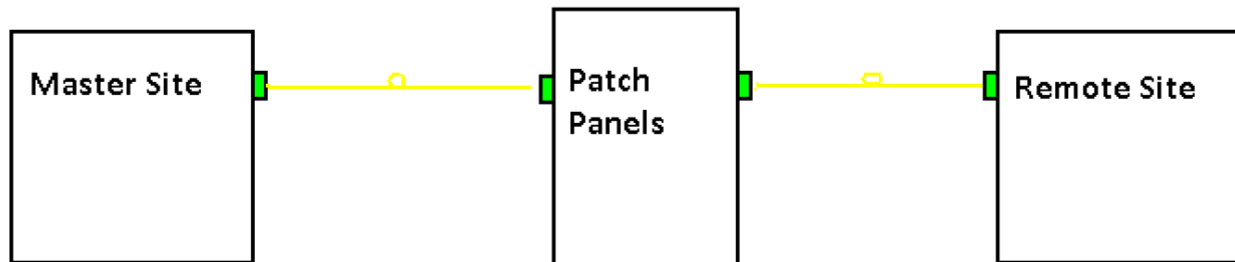

Block Diagram of a Fiber Plant

Once the fiber plant is installed, the system integrator will be required to perform optical test measurements to ensure that the fiber plant is within operating specifications prior to the installation of any fiber DAS equipment. The quality of the optical path must be checked throughout the entire length of the fiber plant to determine optical reliability (aka, end-to-end testing). All fiber connectors, including fusion splicing, must be certified to meet industry standards. An Optical Time Domain Reflectometer (OTDR) is used to test and certify the optical performance of the fiber plant by identifying reflection points throughout the entire length of the fiber path. Any reflections will degrade the linearity of a fiber optic link and introduce noise, thus why it is important to confirm the fiber is working within tolerance. It is best to keep all discrete reflections to <60 dB.

#### Differences in SC Fiber Connectors:

The SC/APC connector can be identified by a green connector boot and square body. The fiber end is angle-polished to 8° and offers a large surface area of contact between the mating connectors. The APC improves coupling efficiency and minimizes connector back reflection or return loss characteristics, thus keeping the return loss below <60 dB.



Example of a SC/APC Connector

APC = Angle Polish Connector



Up to 0.00032% Back Reflection

With "Angled Physical Contact" (APC) finishes, the connector tip is cut to 8 degrees, which directs the reflected light away from the source.

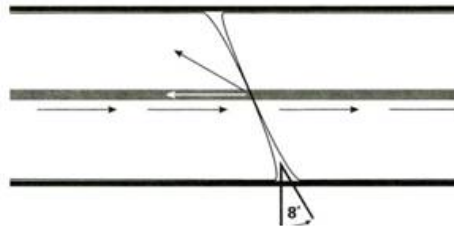

Example of the APC 8° Mating Core Face

The SC/UPC connector looks very similar but is the incorrect connector type when it comes to analog fiber DAS deployment, it is generally identified by a blue square body and uses an ultra-physical contact (UPC) of 0°.

**WARNING:** This type of connector must not be used anywhere within the fiber plant network, the insertion loss (reflectance) is too high and will disrupt the communications between fiber master and fiber remote equipment and preventing the system from being commissioned.



Example of a SC/APC Connector

UPC = Ultra Polish Connector



Up to 0.001% Back Reflection

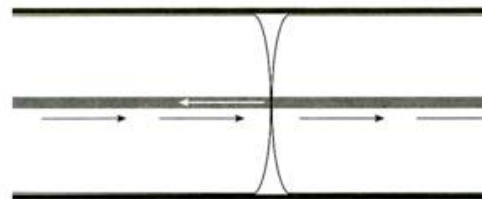

Example of the UPC 0° Mating Core Face

**Avoiding Fiber Contamination and Creating Reliable Fiber Connections:**

There are 3 basic principles that are critical to achieving an efficient and reliable fiber optic link:

- Optimal Core Alignment
- Physical Contact
- Clean Connector Interface

Current connector design and manufacturing techniques have eliminated most of the challenges to achieving core alignment and physical contact. What remains challenging is maintaining a clean connector interface.

Faulty connections and contamination are the number one source of troubleshooting in optical networks. A single particle mated into the core of a fiber can cause significant back reflection (Return Loss), insertion loss, and ultimately damage equipment. Clean optic fiber components are imperative to the quality of optical performance within any fiber link. It is the most basic and important procedure to be carried out before mating together any optic fiber assembly. Any contamination within the fiber connection can cause failure of that component and even failure of the entire system. Thus, clean components are a necessity for quality connections with optic fibers. When cleaning fiber components, the procedure must be followed correctly and precisely with the goal of eliminating any dust or foreign contamination. A clean component will connect properly; however, a dirty component may transfer contamination to the mating connector or may even damage the optical contacts. Always remember that components are not guaranteed to be clean on receipt from the supplier. Any foreign object partially or completely blocking the fiber core will result in strong back reflections and cause the laser system to become unstable.

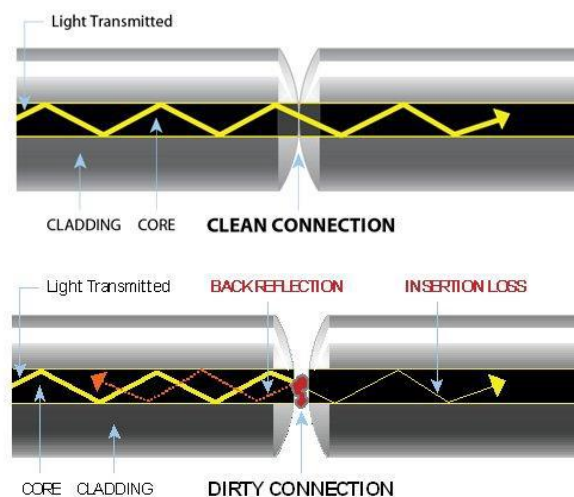

For example, a 1-micron (0.001 mm) dust particle on a single-mode core can block up to 1% of the light (a 0.05dB loss), a 9-micron (0.009 mm) speck can completely block the fiber core.

Examples of contamination:

- Oils - frequently from human hands
- Film residues - condensed from vapors in the air
- Powdery coatings - left after water or other solvents evaporate away

Particles trapped between fiber core mating faces can scratch the glass surfaces or cause an air gap which can misalign the fiber mating cores, thus degrading the optical signal path.

Using a “one-click” cleaning tool on each fiber connector before mating the connection points will ensure that the fiber is clean.



## Example of a One-Click Cleaning Tool

The only way to know if the fiber is truly clear of any contamination, or if it is damaged, is by using a fiber optic inspection tool.



Example of a Fiber Optic Inspection Tool

The fiber optic inspection tool allows you to visually inspect the four zones of the fiber connector:

- A. Core Zone
- B. Cladding Zone
- C. Adhesive/Epoxy Zone
- D. Contact/Ferrule Zone

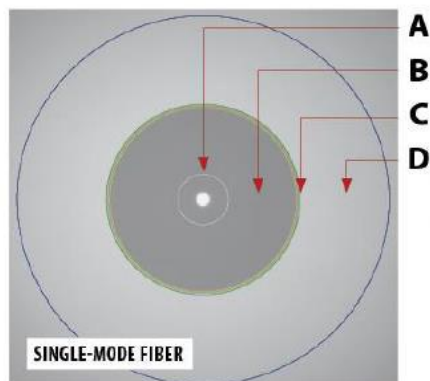

Example of End face Zones

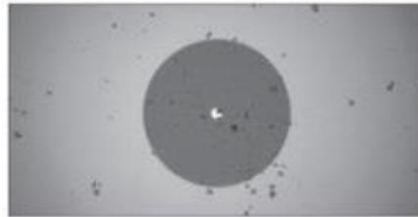
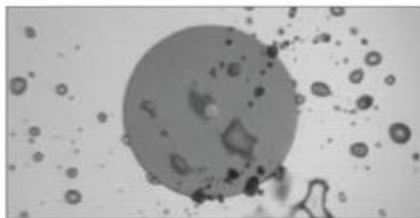
*CLEAN FIBER**PITS / CHIPS**DIRT / CONTAMINATION**OIL / CLEANING FLUID RESIDUE**SCRATCH*

Examples of Various End face Views Using a Fiber Optic Inspection Tool

**Conclusion:**

Visual inspection and cleaning are the only way to determine if fiber connectors are truly reliable before mating them. End-to-End testing with an OTDR, is the only way to know that the entire length of the fiber is within specification and ready for equipment deployment and commissioning. By implementing a simple, yet important, process of proactive visual inspection, cleaning and OTDR testing, poor optical signal performance and potential equipment damage can be avoided.

## 6.12 APPENDIX L: TROUBLESHOOTING V3 ANNUNCIATOR PANEL RS485

If annunciator does not power on or does not appear in GUI after wiring has been confirmed, use a multimeter to check the following pins for resistance and voltage according to the below instructions.

### NG V3 BDA/MU/RU Measurements

1. Turn on the V3 BDA unit
2. Measure the voltage from B->GND and A->GND while AP wiring is connected.

B - GND	~0.0 VDC
A - GND	~3.2 VDC

1. Turn off the V3 BDA unit
2. Disconnect the 3 data wires/terminal block for A/B/GND connection.
3. Measure the resistance of BDA terminals from B->GND, A->GND, and B->A while the V3 BDA is off.

B - GND	~2.3k Ohms
A - GND	~3.5k Ohms
B - A	~6.3k Ohms

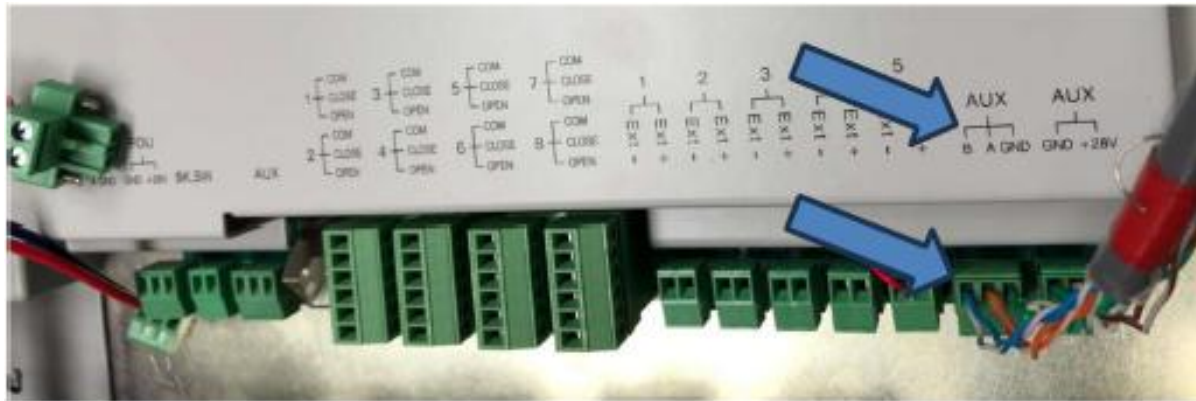

NG V3 BDA/MU/RU

If all above measurements are within specification, continue to troubleshoot the V3 AP. Use a multimeter to check the following pins for resistance according to the below instructions.

1. Turn off the V3 BDA unit
2. Disconnect the 3 data wires/terminal block for A/B/GND connection.
3. Measure the resistance of AP terminals from B->GND, A->GND, and B->A while AP is disconnected.

B - GND	~2.1k Ohms
A - GND	~2.1k Ohms
B - A	~140 Ohms

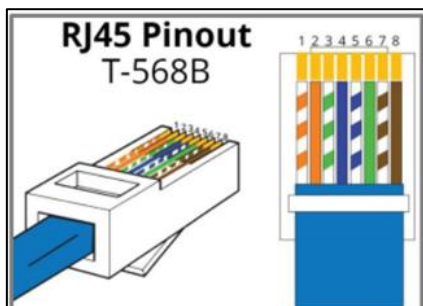

- |                 |                |
|-----------------|----------------|
| 1. White Orange | 5. White Blue  |
| 2. Orange       | 6. Green       |
| 3. White Green  | 7. White Brown |
| 4. Blue         | 8. Brown       |



6.13 APPENDIX M: TROUBLESHOOTING V3 BBU BATTERY RS485

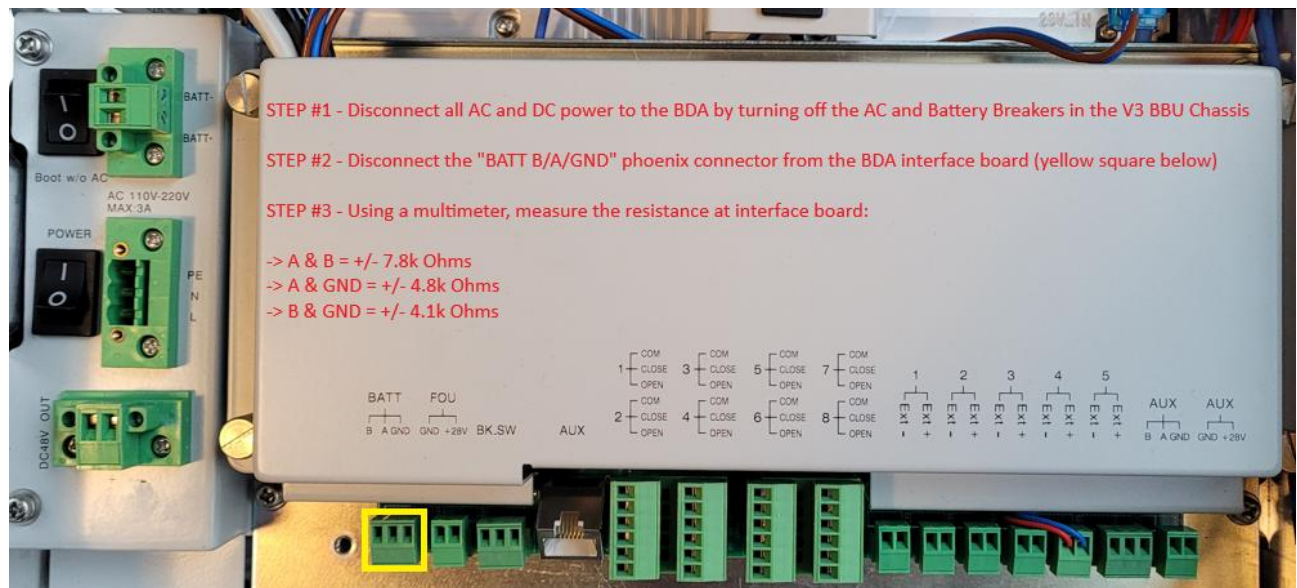
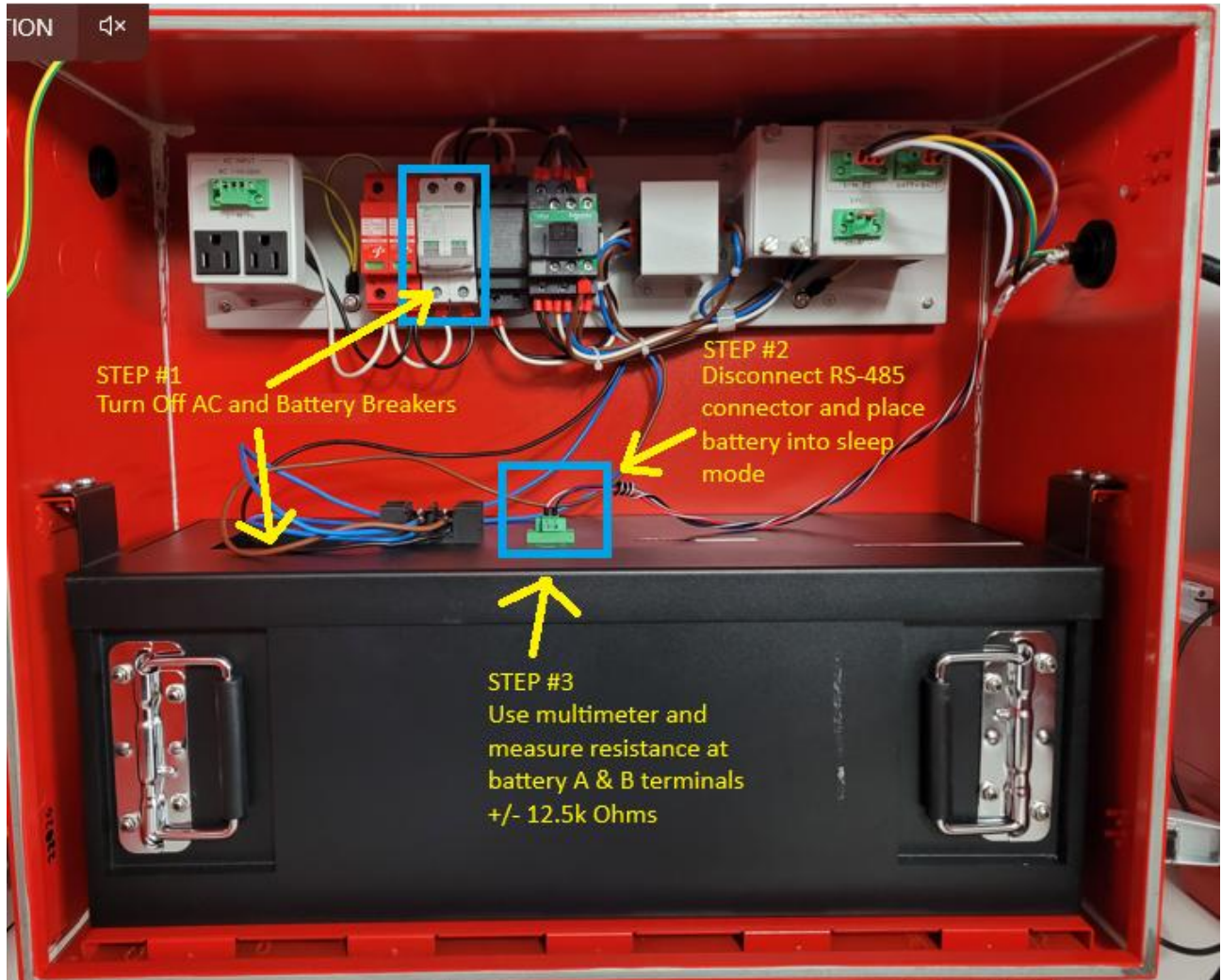

## 6.14 APPENDIX N: V3 VHF/UHF BDA/MU/RU CHARGER REPLACEMENT

### PS V3 VHF/UHF Charger Replacement

1. Power off VHF/UHF BDA
2. Bring VHF/UHF BDA down and place it on the table
3. Remove screws and top cover.

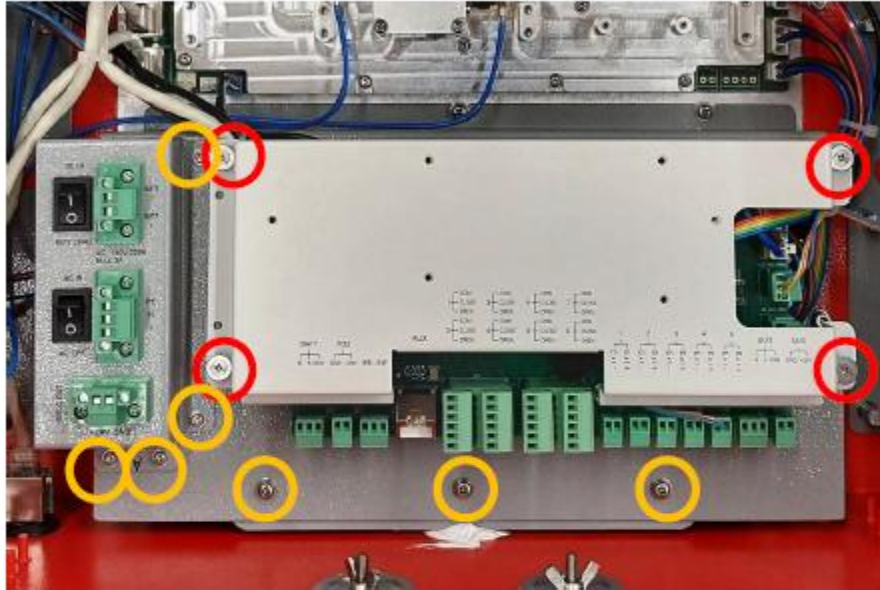

4. Remove cables from the interface board

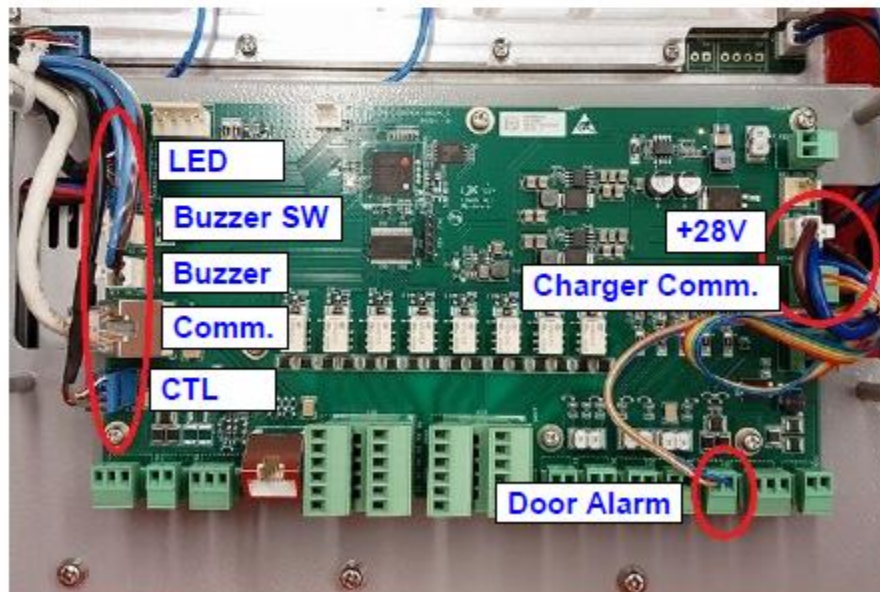

5. Loose below 3pcs screws and remove interface board plate

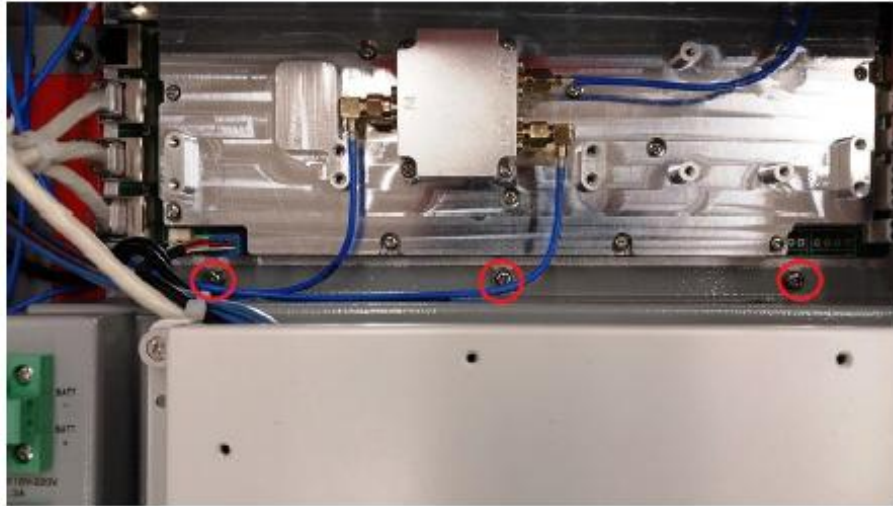

6. Disconnect all cables from the charger

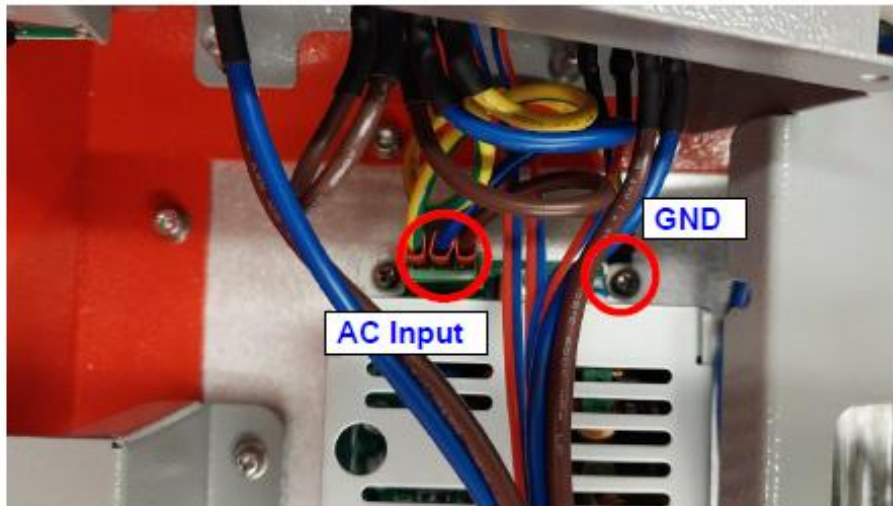

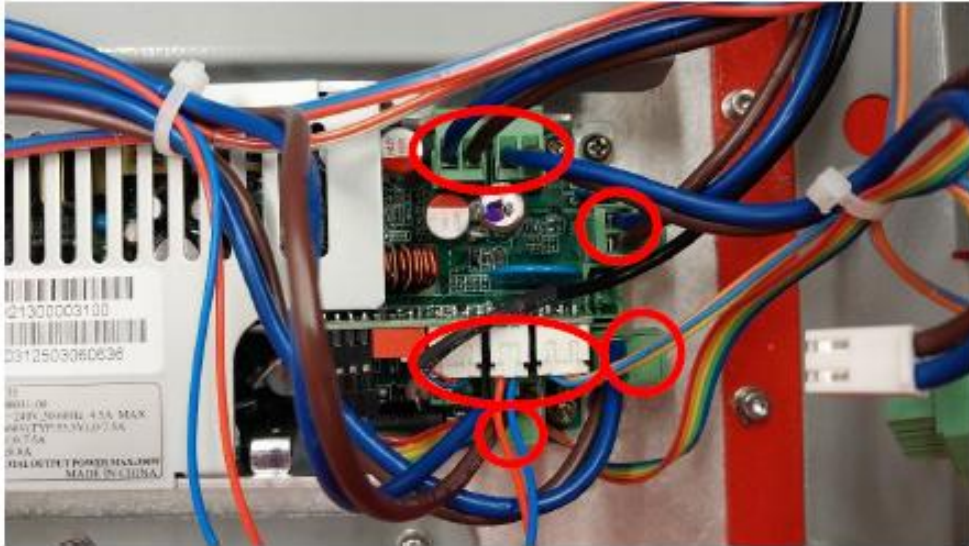

7. Remove 4pcs charger mounting screws at the corner of the charger
8. Remove charger from the chassis using long screw at the left side of the charger.



9. Place new charger and reconnect all cables to new charger.

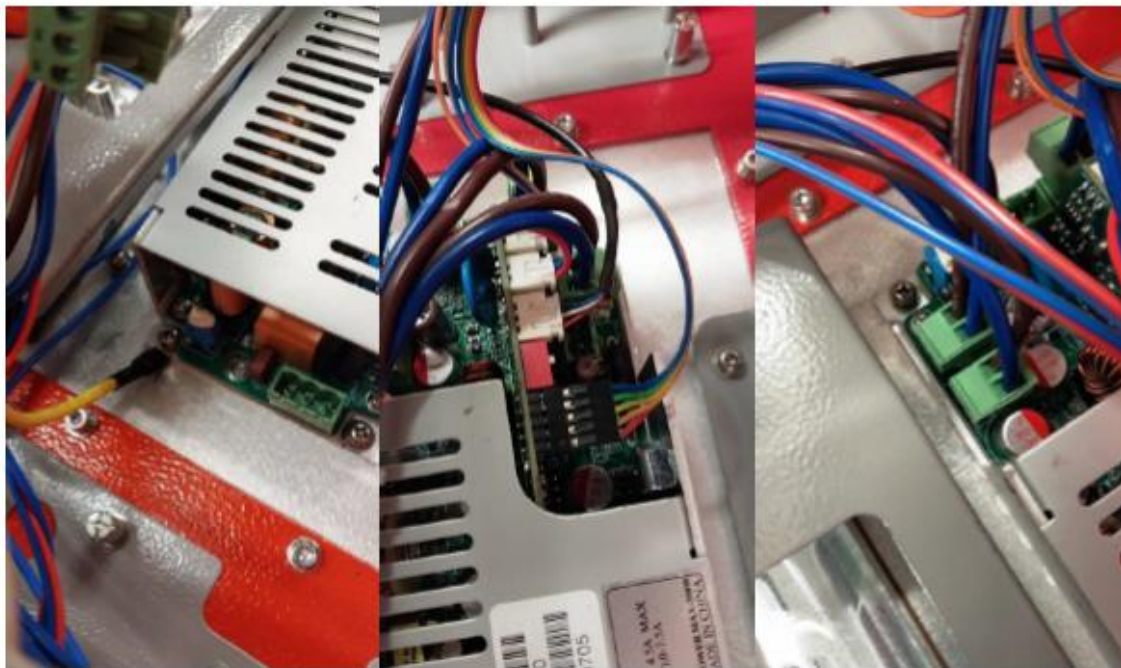
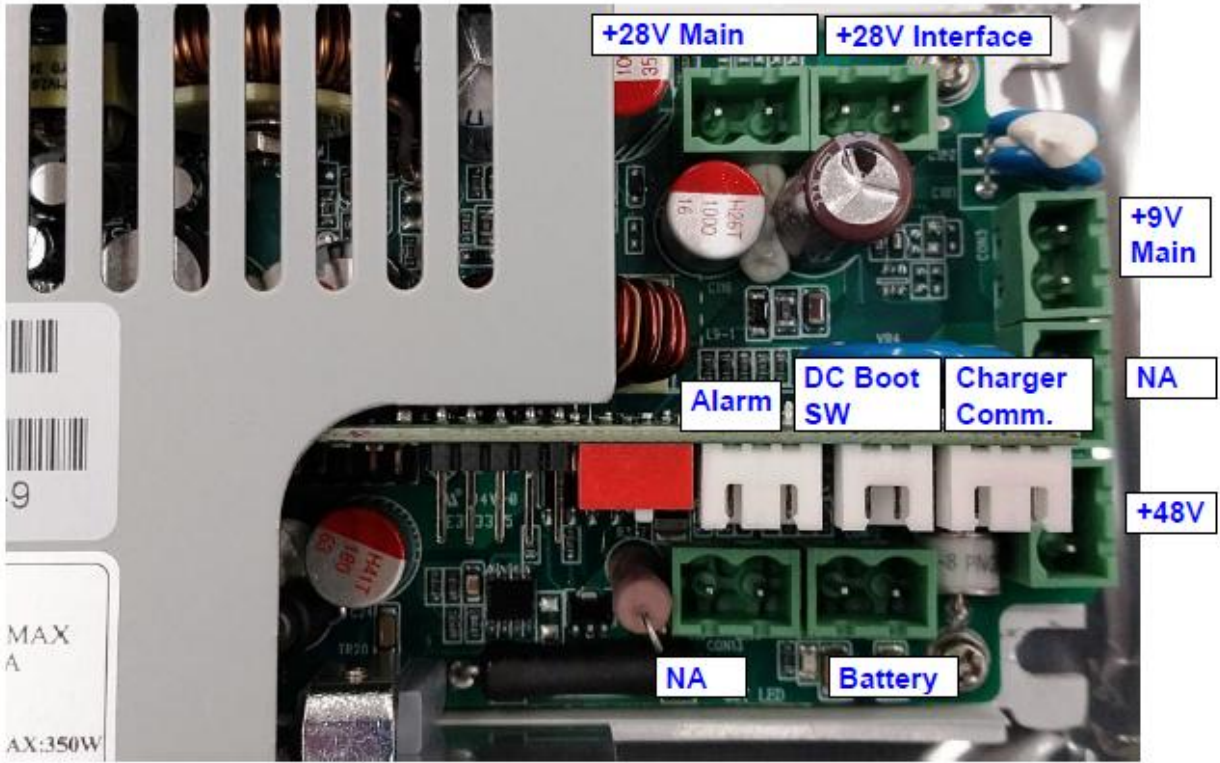

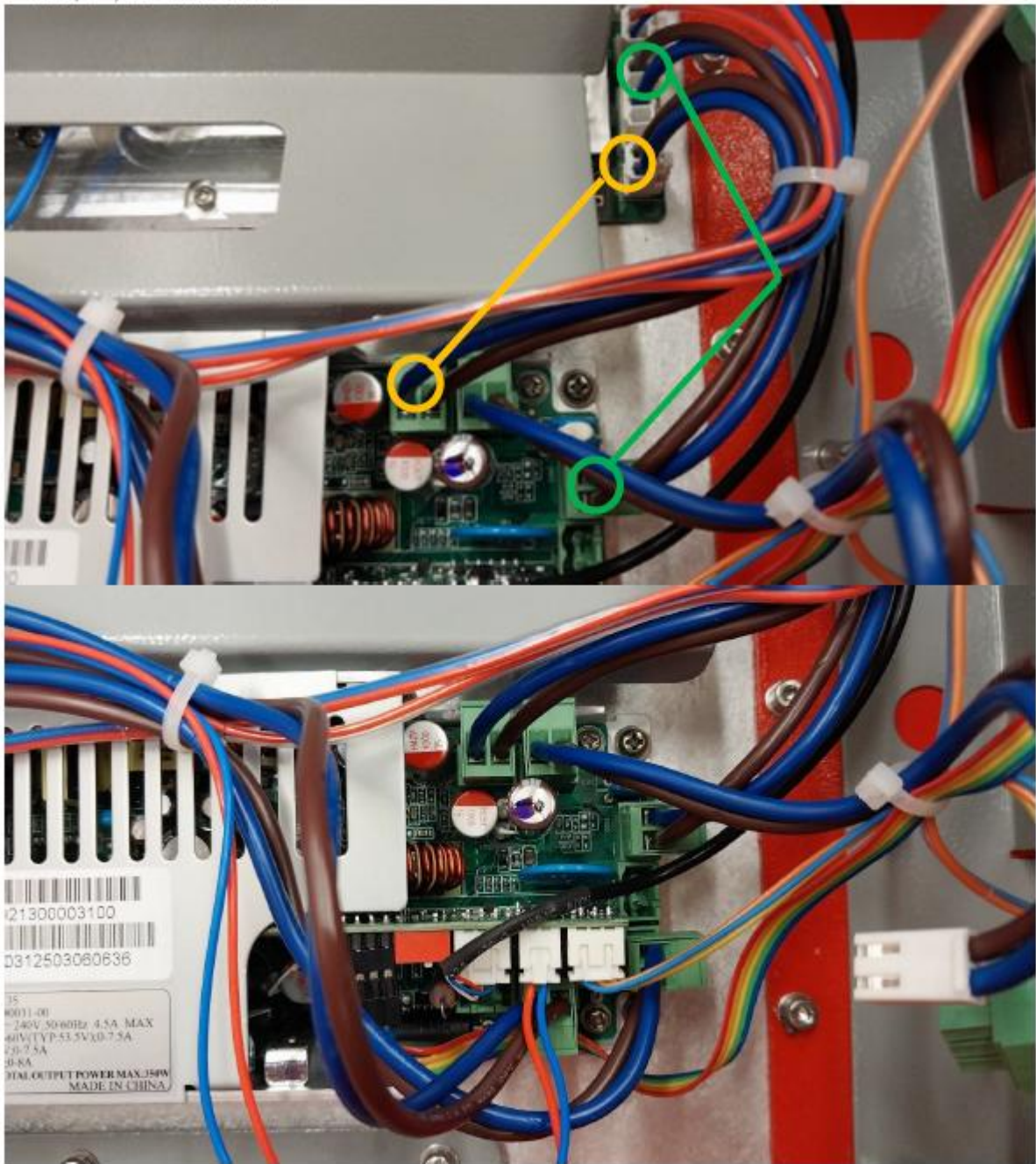

End of Document

# Comba

Comba Telecom Inc.

568 Gibraltar Drive, Milipitas, CA 95035

Tel: +1 408 526 0180

Fax: +1 408 526 0181

Email: [Comba@combausa.com](mailto:Comba@combausa.com)

[www.combausa.com](http://www.combausa.com)

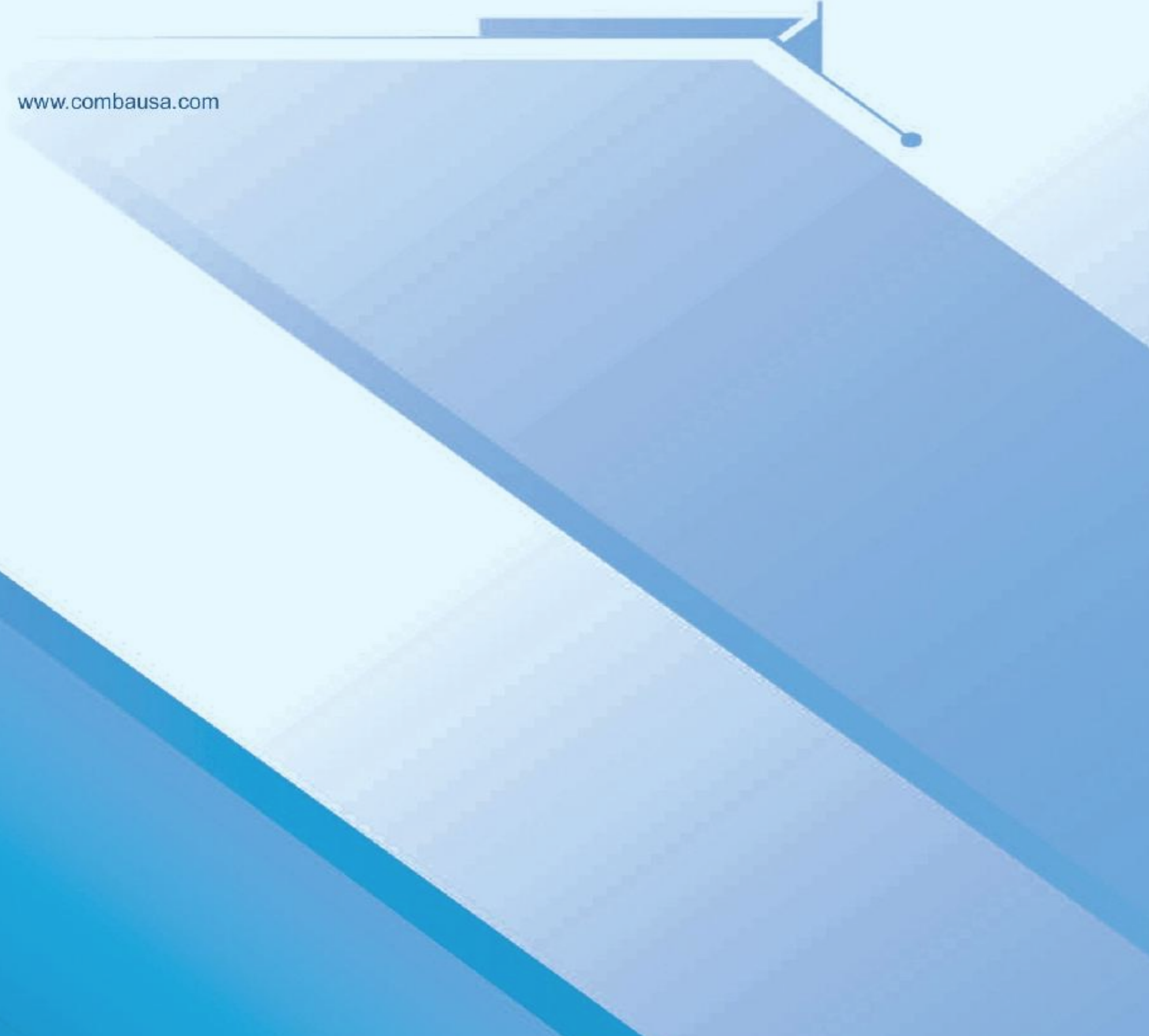
A large, abstract graphic composed of overlapping blue geometric shapes, including a large trapezoid and a smaller rectangle, creating a sense of depth and movement. The colors range from light sky blue to a darker, more saturated blue. The graphic is positioned in the lower half of the page, partially overlapping the contact information.